

UNIVERSIDAD MIGUEL HERNÁNDEZ DE ELCHE



Programa de Doctorado en Estadística, Optimización y Matemática  
Aplicada

PHD DISSERTATION

---

Variaciones locales y cuasilineales del problema de  
Chafee-Infante

Nonlocal quasilinear variations of the Chafee-Infante problem

---

**Author**

*Estefani Moraes Moreira*

---

**Advisor**

Prof. Dr. *José Valero Cuadra*

**Co-advisor**

Prof. Dr. *Alexandre Nolasco de Carvalho*





La presente Tesis Doctoral, titulada “Nonlocal quasilinear variations of the Chafee-Infante problem”, se presenta bajo la modalidad de **tesis convencional** con los siguientes indicios de calidad:

- A. N. Carvalho, Y. Li, T. L. Luna and E. M. Moreira. A non-autonomous bifurcation problem for a non-local scalar onedimensional parabolic equation. *Communications on Pure and Applied Analysis*, **19** (11) 5181-5196 (2020). DOI: 10.3934/cpaa.2020232
- A. N. Carvalho and E. M. Moreira. Stability and hyperbolicity of equilibria for a scalar nonlocal one-dimensional quasilinear parabolic problem. *Journal of Differential Equations*, **300**, 312-336 (2021). DOI: 10.1016/j.jde.2021.07.044
- E. M. Moreira and J. Valero. Structure of the attractor for a non-local Chafee-Infante problem. *J. Math. Anal. Appl.* **507**, (2022), art. no. 125801. DOI: 10.1016/j.jmaa.2021.125801







El Dr. D. José Valero Cuadra, director, y el Dr. D. Alexandre de Nolasco Carvalho, codirector de la tesis doctoral titulada **“Nonlocal quasilinear variations of the Chafee-Infante problem”**

**INFORMAN:**

Que Dña. Estefani Moraes Moreira ha realizado bajo nuestra supervisión el trabajo titulado **“Nonlocal quasilinear variations of the Chafee-Infante problem”** conforme a los términos y condiciones definidos en su Plan de Investigación y de acuerdo al Código de Buenas Prácticas de la Universidad Miguel Hernández de Elche, cumpliendo los objetivos previstos de forma satisfactoria para su defensa pública como tesis doctoral.

Lo que firmamos para los efectos oportunos, en Elche a 1 de diciembre de 2022



Director de la tesis

Dr. D. José Valero Cuadra

Codirector de la tesis

Dr. D. Alexandre de Nolasco Carvalho





El Dr. D. Domingo Morales González, Coordinador del Programa de Doctorado en Estadística, Optimización y Matemática Aplicada

**INFORMA:**

Que Dña. Estefani Moraes Moreira ha realizado bajo la supervisión del Programa de Doctorado el trabajo titulado **“Nonlocal quasilinear variations of the Chafee-Infante problem”** conforme a los términos y condiciones definidos en su Plan de Investigación y de acuerdo al Código de Buenas Prácticas de la Universidad Miguel Hernández de Elche, cumpliendo los objetivos previstos de forma satisfactoria para su defensa pública como tesis doctoral.

Lo que firmo para los efectos oportunos, en Elche a 1 de diciembre de 2022



Prof. Dr. Domingo Morales González  
Coordinador del Programa de Doctorado  
en Estadística, Optimización y Matemática Aplicada







Estefani Moraes Moreira, autora de la tesis doctoral titulada "Nonlocal quasilinear variations of the Chafee-Infante problem "

**DECLARA**

Que durante el periodo predoctoral ha sido beneficiario de becas de Fundação de Amparo à Pesquisa do Estado de São Paulo (FAPESP), Grants #2018/00065-9 and #2020/00104-4, and CAPES.





# ACKNOWLEDGEMENTS

---

---

First, I want to acknowledge the importance of some people during the period of my PhD studies. I would like to thank all the professors who have taught me the courses, I have learned very much because of them. I just want to thank all the people who played a part in my formation as a mathematician and also as a person. I don't think it is reasonable to mention names because there are so many people I'm grateful for.

Secondly, I want to give a special thank you to all the employees from the ICMC and UMH de Elche for providing me with a good environment to pursue my studies.

I want to thank the people who shared an office with me in the ICMC (Lab 3-252) and in the CIO. All of you were very supportive and I'm thankful for your kindness and friendship. I also want to mention my gratitude for the people from the Universidad Complutense de Madrid who were very receptive during my stay in Madrid. Personally, I'm very grateful for my friend Talita and my PhD colleagues, especially Eder, Estela and Javier, who have been my partners since 2018. Also, to Alex, Carlos e Gabriela, I have no words to express how thankful I am for helping me face a very difficult time. To not take the risk of forgetting some names, I really appreciate every person who supported me during this particular time and during my PhD.

I also want to thank all my family. My special thanks will always be reserved for my parents, Haide and Everaldo, because they are my support and they believe in me more than I do myself.

I want to thank my advisors Alexandre Nolasco de Carvalho and José Valero and my co-advisor Marcelo José Dias Nascimento for the much that they have taught me, for all their patience. I am very glad to have had the opportunity to learn from you.

I want to acknowledge that Coordenação de Aperfeiçoamento de Pessoal de Ensino Superior (CAPES) and Fundação de Amparo à Pesquisa do Estado de São Paulo - FAPESP provided me the financial support during my doctorate. This work was supported by CAPES and FAPESP Grants #2018/00065-9 and #2020/00104-4.



# RESUMO

MOREIRA, E. M. **Variações não-locais e quasilineares do problema de Chafee-Infante** . 2022. 152 p. Tese (Doutorado em Ciências – Matemática) – Instituto de Ciências Matemáticas e de Computação, Universidade de São Paulo, São Carlos – SP, 2022.

Neste trabalho, desenvolvemos alguns resultados sobre variações não-locais e quasilineares do problema de Chafee-Infante. No caso quasilinear não-autônomo, vamos demonstrar a existência de soluções especiais conhecidas como “equilíbrios não-autônomos”. No caso quasilinear autônomo, vamos exibir a existência de uma sequência de bifurcação de equilíbrios, analisaremos sua estabilidade e hiperbolicidade. Também exibiremos a estrutura do atrator para um caso particular. No último capítulo vamos construir um conceito de bloco isolante para problemas multivaluados e fazer uma aplicação de tal conceito.

**Palavras-chave:** Problemas não-locais, problemas de Chafee-Infante, problemas quasilineares, hiperbolicidade, estrutura de atrator, bifurcação.





# ABSTRACT

MOREIRA, E. M. **Nonlocal quasilinear variations of the Chafee-Infante problem.** 2022. 152 p. Tese (Doutorado em Ciências – Matemática) – Instituto de Ciências Matemáticas e de Computação, Universidade de São Paulo, São Carlos – SP, 2022.

In this work, we developed some results on nonlocal quasilinear variations of the Chafee-Infante problem. In the non-autonomous quasilinear case, we will show the existence of special solutions known as “non-autonomous equilibria”. In the autonomous quasilinear case, we will exhibit the existence of a sequence of bifurcation of equilibria, for which we will analyze the stability and hyperbolicity. We will also exhibit the attractor of the global attractor for a particular case. In the last chapter, we will construct a concept of isolating block for multivalued problems and we will make an application of such concept.

**Keywords:** Nonlocal problems, Chafee-Infante problems, quasilinear problems, hyperbolicity, structure of the attractor, bifurcation.







# RESUMEN

MOREIRA, E. M. **Variações não-locais e quasilineares do problema de Chafee-Infante** . 2022. 152 p. Tese (Doutorado em Ciências – Matemática) – Instituto de Ciências Matemáticas e de Computação, Universidade de São Paulo, São Carlos – SP, 2022.

En este trabajo desarrollamos algunos resultados sobre variaciones cuasilineales no-locales del problema de Chafee-Infante. En el caso cuasilineal no-autónomo, vamos a demostrar la existencia de soluciones especiales conocidas como “equilibrios no-autónomos”. En el caso cuasilineal autónomo, vamos a exhibimos la existencia de una secuencia de bifurcación de equilibrios, para los cuales analizaremos su estabilidad e hiperbolicidad. También exhibiremos la estructura del atractor para un caso particular. En el último capítulo, vamos a construir un concepto de bloque aislante para problemas multivaluados y hacer una aplicación de tal concepto.

**Palabras clave:** Problemas no locales, problemas de Chafee-Infante, problemas cuasilineales, hiperbolicidad, estructura del atractor, bifurcación.





# LIST OF FIGURES

---

---

Figure 1 – Representations of the attractor for the Chafee-Infante problem, $\lambda \in (0, 16)$ . Figures inspired by (HENRY, 1981, p. 5) . . . . .	20
Figure 2 – Example of a curve $\Gamma$ . . . . .	36
Figure 3 – Representation of the set $X_1^+$ . . . . .	73
Figure 4 – A representation of the region $X_2^+$ . . . . .	74
Figure 5 – Spectrum of $L_\varepsilon$ . . . . .	87
Figure 6 – Graphs of $a_1$ (in gray) and $\nu c_1^\pm$ (in blue) for different choices of $\nu$ . . . . .	93
Figure 7 – Graphs of $a_2$ and $\nu c_1^\pm$ (in blue) for different choices of $\nu$ . . . . .	93
Figure 8 – Graphs of $a_3$ (in gray), $\nu c_1^\pm$ (in blue) and $\nu c_2^\pm$ (in green) for different choices of $\nu$ . . . . .	94
Figure 9 – Expected structure of the attractor, when $\nu \in (\nu_3, \nu_5)$ . . . . .	94
Figure 10 – Graphs of $a_4$ (in gray) and $\nu c_1^\pm$ (in green) for different choices of $\nu$ . . . . .	95
Figure 11 – Graphs of $a_5$ (in gray) and $\nu c_1^\pm$ (in green) for different choices of $\nu$ . . . . .	95
Figure 12 – Graphs of $a_6$ (in gray) and $\nu c_1^\pm$ (in green) for different choices of $\nu$ . . . . .	95
Figure 13 – Isolating block of a saddle-point . . . . .	111
Figure 14 – Representation of the Heaviside function . . . . .	134



# CONTENTS

---

---

1	INTRODUCTION . . . . .	19
2	ABSTRACT THEORY OF ATTRACTORS . . . . .	23
2.1	The autonomous problem . . . . .	23
2.1.1	<i>Conley index and connection matrix</i> . . . . .	28
2.2	Non-autonomous problems . . . . .	32
2.3	Semilinear problems . . . . .	35
2.3.1	<i>The linear theory</i> . . . . .	35
2.3.2	<i>Existence of solution for the semilinear problem</i> . . . . .	39
2.3.3	<i>Comparison results</i> . . . . .	42
2.3.4	<i>Stability and of equilibria</i> . . . . .	43
2.3.5	<i>Local information near an equilibrium of (2.3)</i> . . . . .	44
2.3.6	<i>Hyperbolic solutions</i> . . . . .	45
3	THE CHAFEE-INFANTE PROBLEM AND ITS NON-AUTONOMOUS VARIATION . . . . .	51
3.1	The bifurcation of the Chafee-Infante problem . . . . .	52
3.2	Structure of the attractor and Morse Smale semigroup . . . . .	56
3.3	Identifying the structure of a global attractor . . . . .	59
3.4	A non-autonomous Chafee-Infante problem . . . . .	60
3.5	Further comments and open problems . . . . .	62
4	A NON-AUTONOMOUS PARABOLIC PROBLEM . . . . .	65
4.1	Non-autonomous problem . . . . .	66
4.2	Global well-posedness . . . . .	67
4.3	Existence of pullback attractor . . . . .	70
4.4	Non-autonomous equilibria . . . . .	72
4.5	Some remarks and open problems for further investigations . . . . .	76
5	THE AUTONOMOUS PROBLEM . . . . .	77
5.1	Existence of the attractor . . . . .	78
5.2	Equilibria of the autonomous problem . . . . .	79
5.3	Hyperbolicity of the equilibria of (5.3) . . . . .	82
5.4	Hyperbolicity of equilibria of the nonlocal quasilinear problem (5.1) . . . . .	87

5.5	Bifurcation of equilibria for a few examples . . . . .	89
5.6	Structure of the global attractor for <i>a</i> non-decreasing . . . . .	96
5.7	Some remarks and further investigations . . . . .	108
6	<b>MULTIVALUED PROBLEMS</b> . . . . .	109
6.1	Basic definitions . . . . .	111
6.1.1	<i>A differential inclusion with Lipschitz nonlinearity</i> . . . . .	115
6.2	Existence of the isolating block in the multivalued case . . . . .	117
6.3	Application . . . . .	133
6.3.1	<i>Previous results</i> . . . . .	134
6.3.2	<i>Isolating block</i> . . . . .	136
6.3.3	<i>Uniqueness of solutions</i> . . . . .	140
6.4	Conclusion and next steps . . . . .	145
	<b>BIBLIOGRAPHY</b> . . . . .	147









---

## INTRODUCTION

---

The study of the inner structure of attractors for scalar semilinear parabolic problems with local diffusivity is considerably well understood and many very interesting results are available in the literature (see, for example, (CARVALHO; LANGA; ROBINSON, 2013) and references therein). The description of the inner structure for non-local models is much less exploited. Our aim is to provide some techniques to unravel the dynamics of such non-local models in both autonomous and non-autonomous frameworks.

Related to the inner structure of attractor, we wish to understand properties that are robust under Lipschitz perturbations such as hyperbolicity (in the autonomous context) or exponential dichotomy (in the nonautonomous setting). A lot of the geometric theory for nonlinear dynamical systems can be found in (HENRY, 1981). Another approach to find answers for the inner structure is using topological theory such as homology and connection matrix theories. In this thesis, we will consider both approaches.

We will explore problems in the one-dimensional bounded domain. In this situation, we have more information about the spectral theory of linear operators, that is because we will use the fact we understand very well the so-called Sturm-Liouville operators, see (SAGAN, 1961) for more details.

The theory of semigroup and evolution process has been developed intensively from the last century until now. We can find several problems for which there is a semigroup or process related to them. In fact, we can also find examples for which there is a compact set (or a family of compact sets), which is called an attractor, that describes the dynamics of the problem.

There is a particular class of semigroups, called gradient semigroups, that interest us most. In fact, if the number of equilibria is finite, we can say that the attractor of a gradient semigroup, if it exists, is the set of global bounded solutions that connects two distinct equilibria (that is, stationary points under the action of the semigroup). Thus, it is important to understand the behavior of the solutions near each equilibrium. To be more precise, we search for aspects of

the dynamics which are robust under perturbation.

After understanding how the semiflow acts close to each equilibrium, the following question would be to understand the semiflow restricted to the attractor. For instance, it is interesting to see if we have transversality.

The best well-understood attractor is the one associated with the Chafee-Infante problem. This problem is a one-dimensional scalar semilinear problem depending on a parameter  $\lambda > 0$  and it generates a gradient semigroup, whose number of equilibria depends on the position of the parameter  $\lambda > 0$ . Also, the Chafee-Infante problem firstly appeared in the literature in the seventies, see (CHAFEE; INFANTE, 1974; CHAFEE; INFANTE, 1974/75), but the description of its attractor was finalized much later, after contributions of several authors along the years. We will explore more about this problem later and we will give references for the ones who wish to pursue a further study on it.

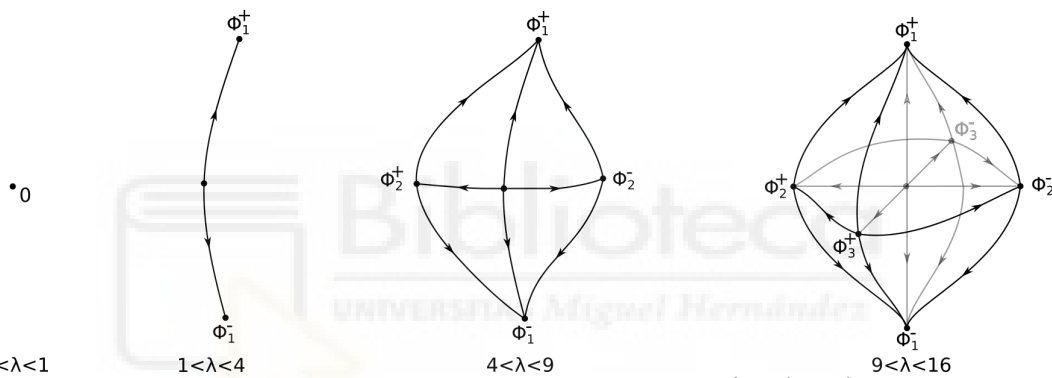

Figure 1 – Representations of the attractor for the Chafee-Infante problem,  $\lambda \in (0, 16)$ . Figures inspired by (HENRY, 1981, p. 5)

There are some topological theory developed in order to obtain local information inside the attractor of a semigroup. Several authors collaborated in this subject, such as C. Conley, K. Rybakowski, H. Kurland, R. Franzosa and many others.

Conley in (CONLEY, 1978) defines the concept of homology index (today known as “Conley index”) of an isolated invariant set of a flow acting in a compact space. The Conley index basically associates an invariant set, satisfying additional properties, with a topological pointed space defined by a special neighborhood of the invariant set. In (RYBAKOWSKI, 1987), Rybakowski has generalized the concept of Conley index for semiflows acting in non-locally compact metric spaces.

The Conley index can be applied to study bifurcations of equilibria and existence of connections. This concept is also robust under perturbations.

Now, R. Franzosa (see (FRANZOSA, 1986; FRANZOSA, 1988; FRANZOSA, 1989)) has developed the concept of connection matrix for a flow admitting a Morse decomposition. The author has defined a matrix, such that each entry is a boundary map for a long exact sequence defined by two distinct elements of the Morse decomposition. If an entry of a connection matrix

is non-zero, then it exists of a connection between two elements of the Morse decomposition. It is important to mention that there may exist more than one connection matrix associated with a Morse decomposition.

All of these geometry and topological properties commented above are in the content of univalued semiflow, that is, problems for which we do have uniqueness of solutions. But in this thesis, we are also interested in exploring the multivalued case.

Since the beginning of the last century, several authors (see e.g. (ARRIETA; RODRÍGUEZ-BERNAL; VALERO, 2006; BALL, 2000; DASHKOVSKIY; KAPUSTYAN; PERESTYUK, 2021; MELNIK; VALERO, 1998; ZGUROVSKY *et al.*, 2012) and the references therein among many others) have been studying attractors in this context, which is a very challenging subject. Even if the attractor exists, it is not clear how to understand its structure, since we lack a definition of hyperbolicity on the multivalued case. Differently from the univalued case, we cannot expect the multivalued semiflow to be injective inside its attractor, which could be helpful in the local analysis.

It has been a clear development in the topological theory for the study of attractors in the multivalued case. For instance, there are many definitions of homology index in this context, see for instance (DZEDZEJ; GABOR, 2011; MROZEK, 1990). On the other hand, we have not seen any construction of isolating blocks, special bounded sets such that each point of the boundary is oriented under the action of the semiflow.

The isolating block sets are directly related with the definition of Conley's index univalued case. Thus, understanding such concepts in the multivalued setting may help us to analyze local information in the attractor.

In this thesis, we present results related to two nlocal problems studied by this author and her collaborators.

First, we consider this non autonomous problem

$$\begin{cases} u_t - a(\|u_x\|^2)u_{xx} = \lambda u - \beta(t)u^3, & x \in (0, \pi), t > s, \\ u(0, t) = u(\pi, t) = 0, & t \geq s, \\ u(\cdot, s) = u_0(\cdot) \in H_0^1(0, \pi), \end{cases}$$

with  $a \in C^1(\mathbb{R}^+)$  and  $\beta : \mathbb{R} \rightarrow [b_1, b_2]$  is a globally Lipschitz function,  $b_2 > b_1 > 0$ .

We will show the existence of a sequence of bifurcation of global solutions known as non-autonomous equilibria.

We also consider this the autonomous problem

$$\begin{cases} u_t = a(\|u_x\|^2)u_{xx} + \lambda f(u), & x \in (0, \pi), t > 0, \\ u(0, t) = u(\pi, t) = 0, & t \geq 0, \\ u(0) = u_0 \in H_0^1(0, \pi). \end{cases}$$

for a function  $a \in C^1(\mathbb{R}^+)$  and  $f \in C^2(\mathbb{R})$  with other convenient conditions. We will analyze the existence of solutions, bifurcations of equilibria and the inner structure of the attractor. If the term  $a(\|u_x\|^2) \neq \text{constant}$ , we have a nonlocal quasilinear problem.

We will consider the problem above when  $a(\cdot)$  is increasing and we will show that we can have results analogous to the ones for the Chafee-Infante problem. Without this monotonicity assumption, we will show that we may also have an infinity of equilibria, which includes the possibility of having a continuum of equilibria.

This thesis is organized as follows: In the second chapter, we present basic concepts and results of nonlinear dynamical systems. That includes the abstract theory of attractors in the autonomous and non-autonomous setting and also some abstract results for semilinear problems. In chapter three, we will consider the Chafee-Infante problem and its following variations, including its non autonomous version presented in (CARVALHO; LANGA; ROBINSON, 2012). In the next chapters, the reader can find results that were developed during my PhD, by this author and her collaborators. In Chapter four, we will analyze the non-autonomous nonlocal problem commented before. See the reference (LI *et al.*, 2020). In Chapter five, we will consider its autonomous version. You can also find these results in (CARVALHO; MOREIRA, 2021), (MOREIRA; VALERO, 2022b) and the paper submitted for publication (ARRIETA *et al.*, 2022). Finally, in Chapter six, we will construct isolating blocks for multivalued semiflows and give an application in differential inclusions, see (MOREIRA; VALERO, 2022a).

---

# ABSTRACT THEORY OF ATTRACTORS

---

In this thesis, we are interested in the study of the inner structure of attractors. To introduce the results, we need to present abstract results for autonomous and non-autonomous problems. For instance, results on the existence of global solutions and the continuity with respect to initial conditions. Also, we are interested in identifying important subsets under the action of the dynamics.

This chapter is divided into three parts. First, we will approach the abstract autonomous theory, which includes topics of existence of local and global solutions, the concepts of semigroup and global attractors. We will also present abstract geometric and topological theories that can be used to characterize the inner structure of attractors.

In the second part, we present basic results on the existence of global solutions for non-autonomous problems, the concept of process and pullback attractor, and conditions to guarantee their existence. We will present the definition of non-autonomous equilibria (first defined in (CARVALHO; LANGA; ROBINSON, 2012)).

In the last part, we will consider the class of semilinear problems and present the concepts of saddle-node property and exponential dichotomy.

## 2.1 The autonomous problem

In this section, we will present basic results on the existence of global solutions for a autonomous problem and the concept of semigroups. There is a special class of semigroups we are interested in characterizing their attractors, the so-called gradient semigroup. Later, we will make a brief exposition of the topological techniques, such as Conley's index and connection matrix. The results we present here are just the basics in order to understand the applications that come from the next chapters. For a profound study of the theory of semigroups, we recommend (PAZY, 1983; CHOLEWA; DLOTKO, 2000; LADYZHENSKAYA, 1991) and for the topological

theory see (CONLEY, 1978; RYBAKOWSKI, 1987; FRANZOSA, 1989).

Consider  $X$  a Banach space and denote by  $C(X)$  the set of all continuous functions from  $X$  to itself, and by  $\mathcal{L}(X)$  as the subset of  $C(X)$  given by the linear operators.

**Definition 2.1.1.** We say that a family  $\{T(t) : t \geq 0\} \subset C(X)$  is a semigroup if it satisfies

- i)  $T(0) = I_X$ , where  $I_X$  denotes the identity operator in  $C(X)$ ;
- ii)  $T(t+s) = T(t)T(s)$ , for all  $t, s \in \mathbb{R}^+$ ;
- iii) The map  $\mathbb{R} \times X \ni (t, x) \mapsto T(t)x$  is continuous.

**Definition 2.1.2.** We say that  $\xi : \mathbb{R} \rightarrow X$  is a global solution for  $\{T(t) : t \geq 0\}$  if  $\xi(s+t) = T(t)\xi(s)$ , for all  $t \geq 0$  and  $s \in \mathbb{R}$ .

**Definition 2.1.3.** We say that  $B \subset X$  is positively (resp. negatively) invariant for  $\{T(t) : t \geq 0\}$  if  $T(t)B \subset B$  (resp.  $B \subset T(t)B$ ), for all  $t \geq 0$ .

If  $B$  is positively and negatively invariant, we say that  $B$  is invariant. In this case,  $T(t)B = B$ , for all  $t \geq 0$ .

If for some  $x^* \in X$ , the set  $\{x^*\}$  is invariant for  $\{T(t) : t \geq 0\}$ ,  $x^*$  is called an equilibrium of  $\{T(t) : t \geq 0\}$ .

**Definition 2.1.4.** A set  $\mathcal{A} \subset X$  is the global attractor of  $\{T(t) : t \geq 0\}$  if

- i)  $\mathcal{A}$  is compact;
- ii)  $\mathcal{A}$  is invariant, that is,  $T(t)\mathcal{A} = \mathcal{A}$ , for all  $t \geq 0$ ;
- iii)  $\mathcal{A}$  attracts bounded sets under the action of  $\{T(t) : t \geq 0\}$ : for each bounded set  $B \subset X$ , we have that

$$\lim_{t \rightarrow +\infty} \sup_{b \in B} d(T(t)b, \mathcal{A}) = 0.$$

When  $\mathcal{A}$  exists, it can be characterized as

$$\mathcal{A} = \{\text{The space of all the bounded global solutions of } \{T(t) : t \geq 0\}\}.$$

In this thesis we are mostly interested in studying the structure of the attractor. In order to pursue this subject, we will first present sufficient conditions to guarantee the existence of the attractor.

Later we will define a special class of semigroups, the so-called gradient semigroups.

After this presentation, we will also explore the topological knowledge involving the theory of attractors.

**Definition 2.1.5.** A semigroup  $\{T(t) : t \geq 0\}$  is called bounded dissipative if there is a non-empty bounded set  $D \subset X$  that attracts all the bounded sets of  $X$ . In other words, for each  $B \subset X$  bounded, we have

$$\lim_{t \rightarrow +\infty} \sup_{b \in B} d(T(t)b, D) = 0.$$

**Definition 2.1.6.** A non-empty bounded subset  $D \subset X$  absorbs bounded subset of  $X$ , if for each bounded subset  $B \subset X$ , there is a  $t_B \geq 0$ , such that

$$T(t)B \subset D, \text{ for all } t \geq t_B.$$

This set  $D$  is called an absorbing set of  $X$ .

It can be shown that a semigroup  $\{T(t) : t \geq 0\}$  is bounded dissipative if and only if it admits a non-empty bounded absorbing set.

**Definition 2.1.7.** We say that  $\{T(t) : t \geq 0\}$  is asymptotically compact if given sequences  $\{t_n\}_{n \in \mathbb{N}} \in \mathbb{R}^+$ ,  $\{x_n\}_{n \in \mathbb{N}} \in X$  such that  $t_n \rightarrow +\infty$  and the sequence  $\{x_n\}_{n \in \mathbb{N}}$  bounded, then  $\{T(t_n)x_n\}_{n \in \mathbb{N}}$  has a convergent subsequence.

**Definition 2.1.8.** Consider a semigroup  $\{T(t) : t \geq 0\}$  and a bounded subset  $B$  of  $X$ . We define the  $\omega$ -limit of  $\omega(B)$  as the set

$$\omega(B) = \bigcap_{\tau \geq 0} \overline{\bigcup_{t \geq \tau} T(t)B}.$$

**Theorem 2.1.9.** A semigroup  $\{T(t) : t \geq 0\}$  has a global attractor  $\mathcal{A}$  if, and only if,  $\{T(t) : t \geq 0\}$  is dissipative and asymptotically compact.

Moreover, for  $\mathcal{B} = \{B \subset X : B \neq \emptyset \text{ and } B \text{ is bounded in } X\}$ ,

$$\mathcal{A} = \overline{\bigcup_{D \in \mathcal{B}} \omega(D)}.$$

**Definition 2.1.10.** Consider a semigroup  $\{T(t) : t \geq 0\}$ . We say that  $E \subset X$  is an isolated invariant set of  $\{T(t) : t \geq 0\}$  if it is the maximal invariant set of  $\mathcal{O}_\delta(E) := \{x \in X : \|x - e\|_X < \delta, \text{ for some } e \in E\}$ .

A family of sets  $\mathcal{E} = \{E_1, \dots, E_n\}$ ,  $n \in \mathbb{N}$ , is called a disjoint family of isolated invariant sets if  $E_j$  is an isolated invariant set, for  $j = 1, \dots, n$ , and there is  $\delta > 0$  for which  $\mathcal{O}_\delta(E_j) \cap \mathcal{O}_\delta(E_k) = \emptyset$ , for  $j \neq k$ .

A semigroup  $\{T(t) : t \geq 0\}$  is called gradient with respect to a disjoint family of isolated invariant sets  $\mathcal{E} = \{E_1, \dots, E_n\}$ ,  $n \in \mathbb{N}$ , if can find a continuous function  $V : X \rightarrow \mathbb{R}$  satisfying the following:

- (i) For each  $x \in X$ , the map  $[0, +\infty) \ni t \mapsto V(T(t)x)$  is non-decreasing;

(ii) If, for some  $x \in X$ ,  $V(T(t)x) = V(x)$ , for all  $t \geq 0$ , then  $x \in \bigcup_{j=1}^n E_j$ .

As a consequence of the definition, a gradient semigroup  $\{T(t) : t \geq 0\}$  satisfies the following properties:

(G1) For each bounded global solution  $\xi : \mathbb{R} \rightarrow X$ , with  $\xi(\mathbb{R}) \not\subset \bigcup_{k=1}^n E_k$ , there are  $i, j \in \{1, \dots, n\}$ ,  $i \neq j$ , such that

$$E_j \xleftarrow{t \rightarrow -\infty} \xi(t) \xrightarrow{t \rightarrow +\infty} E_i.$$

(G2) There is no homoclinic structure. That means, we cannot find a  $k \leq n$ , a subset  $\{E_{i_j} : 1 \leq j \leq k\} \subset \mathcal{E}$  and global solutions  $\xi_j : \mathbb{R} \rightarrow X$  such that

$$E_{i_{j+1}} \xleftarrow{t \rightarrow -\infty} \xi_j(t) \xrightarrow{t \rightarrow +\infty} E_{i_j}, \text{ for } 1 \leq j \leq k \text{ and } E_{i_{k+1}} = E_{i_1}.$$

**Remark 2.1.11.** The authors in (CARVALHO; LANGA, 2009) define the class of gradient-like (or dynamically gradient) as the class of semigroups satisfying (G1) and (G2). Initially, they believed the class of such semigroup was larger than the class of gradient semigroups. It was shown in (COSTA *et al.*, 2011, Theorem 1.1) that any dynamically semigroup is also gradient, which means both classes coincide.

**Theorem 2.1.12.** (CARVALHO; LANGA; ROBINSON, 2013, Theorem 2.43) Suppose that  $\{T(t) : t \geq 0\}$  has a global attractor  $\mathcal{A}$ , with a disjoint family of isolated invariant sets  $\mathcal{E} = \{E_1, \dots, E_n\}$ ,  $n \in \mathbb{N}$ . Then we have

$$\mathcal{A} = \bigcup_{k=1}^n W^u(E_k),$$

where  $W^u(E_k) = \{x \in X : \text{there is a global solution } \xi : \mathbb{R} \rightarrow X \text{ such that } d(\xi(t), E_k) \rightarrow 0 \text{ as } t \rightarrow -\infty\}$ .

The interest in studying gradient semigroups arrives from the fact that they are robust under perturbation. That is, for semigroups sufficiently close (in a sense that it will be clear later) to a gradient semigroup are also gradients.

**Definition 2.1.13.** We say the family of semigroups  $\{T_\eta(t) : t \geq 0\}_{\eta \in [0,1]}$  is continuous at  $\eta = 0$  if the map

$$\begin{aligned} T_\eta : \mathbb{R}^+ \times X &\rightarrow X \\ (t, x) &\mapsto T_\eta(t)x \end{aligned}$$

converges uniformly on compact sets as  $\eta \rightarrow 0^+$ . In other words, if  $K \subset X$  is a compact set and  $T \in \mathbb{R}^+$ , we have  $\lim_{\eta \rightarrow 0^+} \sup_{x \in K} \sup_{t \in [0, T]} d(T_\eta(t)x, T_0(t)x) = 0$ .



**Definition 2.1.14.** We say that a family  $\{A_\eta : \eta \in [0, 1]\}$  of subsets of  $X$  is upper semicontinuous (resp. lower semicontinuous) as  $\eta \rightarrow \eta_0$  if

$$\lim_{\eta \rightarrow \eta_0} \sup_{x \in A_\eta} d(x, A_{\eta_0}) = 0 \quad \left( \text{resp. } \lim_{\eta \rightarrow \eta_0} \sup_{x \in A_{\eta_0}} d(x, A_\eta) = 0 \right).$$

**Theorem 2.1.15.** Consider a family of semigroups  $\{T_\eta(t) : t \in \mathbb{R}\}_{\eta \in [0,1]}$  continuous at  $\eta = 0$ . Assume that  $\{T_\eta(t) : t \geq 0\}$  admits a global attractor  $\mathcal{A}_\eta$ , for each  $\eta \in [0, 1]$ . Additionally, assume that  $\overline{\bigcup_{\eta \in [0,1]} \mathcal{A}_\eta}$  is a compact set.

Then  $\{\mathcal{A}_\eta : \eta \in [0, 1]\}$  is upper semicontinuous at  $\eta = 0$ .

**Definition 2.1.16.** We say that the family  $\{T_\eta(t) : t \geq 0\}_{\eta \in [0,1]}$  is collectively asymptotic compact at  $\eta = 0$  if: given sequences  $\{\eta_n\}_{n \in \mathbb{N}} \in [0, 1]$ ,  $\{t_n\}_{n \in \mathbb{N}} \in \mathbb{R}^+$ ,  $\{x_n\}_{n \in \mathbb{N}}$  bounded sequence in  $X$ , for which  $\eta_n \rightarrow 0$  and  $t_n \rightarrow +\infty$ , as  $n \rightarrow +\infty$ , then  $\{T_{\eta_n}(t_n)x_n\}_{n \in \mathbb{N}}$  has a convergent subsequence.

**Theorem 2.1.17.** (COSTA *et al.*, 2011, Theorem 4.3) Consider a family of semigroups  $\{T_\eta(t) : t \geq 0\}_{\eta \in [0,1]} \subset C(X)$  satisfying the following:

- (i) The family  $\{T_\eta(t) : t \geq 0\}_{\eta \in [0,1]}$  is continuous at  $\eta = 0$  and it also collectively asymptotically compact.
- (ii) For each  $\eta \in [0, 1]$ , the semigroup  $\{T_\eta(t) : t \geq 0\}$  has a global attractor  $\mathcal{A}_\eta$ . Also,  $\bigcup_{\eta \in [0,1]} \mathcal{A}_\eta$  is a bounded set of  $X$ .
- (iii) There is a  $p \in \mathbb{N}$ , for each  $\eta \in [0, 1]$ , there is a disjoint family of isolated invariant bounded sets  $\mathcal{E}_\eta = \{E_1^\eta, \dots, E_p^\eta\}$  under the action of  $\{T_\eta(t) : t \geq 0\}$ .  
Additionally, for each  $k = 1, \dots, p$  the family  $\{E_k^\eta\}_{\eta \in [0,1]}$  is continuous at  $\eta = 0$ .
- (iv) The semigroup  $\{T_0(t) : t \geq 0\}$  is dynamically gradient with respect to the family  $\mathcal{E}_0$ .
- (v) There is a  $\delta > 0$  such that  $E_k^\eta$  is the maximal invariant set of  $\{T_\eta(t) : t \geq 0\}$  inside  $\mathcal{O}_\delta(E_k^0)$ , for  $k = 1, \dots, p$ .

Under these conditions, there exists  $\eta_0 \in (0, 1]$  such that  $\{T_\eta(t) : t \geq 0\}$  is dynamically gradient with respect to the family  $\mathcal{E}_\eta$ , for  $\eta \in [0, \eta_0]$ .

In some applications, it will be necessary to order (in some sense) invariant sets inside the attractor.

**Definition 2.1.18.** Let  $\{T(t) : t \geq 0\}$  be a semigroup with attractor  $\mathcal{A}$ .

We say that a subset  $\emptyset \neq A \subset \mathcal{A}$  is a local attractor if there is a  $\delta > 0$  such that  $\omega(\mathcal{O}_\delta(A)) = A$ . We define the repeller of  $A$  as the set  $A^* = \{x \in \mathcal{A} : \omega(x) \cap A = \emptyset\}$ .

**Definition 2.1.19.** Let  $\{T(t) : t \geq 0\}$  be a semigroup with attractor  $\mathcal{A}$ . Consider the family  $\emptyset = A_0 \subset A_1 \subset \dots \subset A_n \subset A_{n+1} = \mathcal{A}$ , where each  $A_j$  is a local attractor,  $j = 1, \dots, n$ . For each  $j \in 1, \dots, n$ , define the sets  $M(j) = A_j \cap A_{j-1}^*$ .

The ordered n-upla  $(M(1), M(2), \dots, M(n))$  is called a Morse decomposition of  $\mathcal{A}$ .

**Remark 2.1.20.** Given a Morse decomposition of  $\mathcal{A}$ , we can construct an associated disjoint family of isolated invariant sets. Under possible reordering, it can be shown that given an isolated family of invariant sets, we also define a Morse decomposition of  $\mathcal{A}$ . See (COSTA *et al.*, 2011, Lemma 2.16) and comments after it.

**Remark 2.1.21.** Instead of indexing the Morse sets in an “interval” of  $\mathbb{N}$ , we can index it in any set that admits a partial order. Consider the ordered pair  $(P, <)$  such that  $P$  is a set and  $<$  is a partial order defined in  $P$ .  $I \subset P$  is an interval if  $a, b \in I$  and  $c \in P$  such that  $a < c < b$  implies that  $c \in I$ . Given two partial orders  $<'$  and  $<$  in  $P$ , we say that  $<'$  is an extension of  $<$  if, for  $a, b \in P$ ,  $a < b$  implies  $a <' b$ .

### 2.1.1 Conley index and connection matrix theories

The Conley index was introduced in (CONLEY, 1978) in the context of flows on locally compact metric spaces. Later, the concept was extended to metric spaces for semiflows on not necessarily locally compact spaces by (RYBAKOWSKI, 1987). The Conley index is a concept that gives a topological description for a neighborhood of an isolated invariant set (in our case, simply an isolated equilibrium). In his book, Conley states the following:

“Every flow on a compact space is uniquely represented as an extension of a chain recurrent flow by a strongly gradient-like flow; that is the flow admits a unique subflow which is chain recurrent and such that the quotient flow is strongly gradient-like” (CONLEY, 1978, p. 17).

Conley’s idea was identifying the chain recurrent set and taking the flow defined on the quotient space  $X$  over the recurrent set, which should be a gradient flow.

Later, the topological theory applied to nonlinear dynamical systems has flourished. Several authors generalized the concept and the results for more general spaces or more general semiflows.

In this subsection we will make a brief exposition of the subject focused on our applications. The definitions and results (such as their proofs) can be found in (RYBAKOWSKI, 1987).

Consider a semigroup  $\{T(t) : t \geq 0\} \in C(X)$ . A closed set  $N \subset X$  is an isolating neighborhood of  $K$  if  $K \in \text{int}(N)$  (the interior of  $N$ ) and  $K$  is closed and the largest invariant set in  $N$ . In that case,  $K$  is called an isolated invariant set.

Let  $Y, N$  be subsets of  $X$  with  $Y \subset N$ . We say that  $Y$  is  $N$ -positively invariant if for given  $x \in Y$  and  $t \geq 0$  such that  $T(s)x \in N$ , for all  $s \in [0, t]$ , it follows that  $T(s)x \in Y$ , for all  $s \in [0, t]$ .

**Definition 2.1.22.** We say that a pair of sets  $\langle N_1, N_2 \rangle$  is an index pair in  $N$  if satisfies:

- i)  $N_1, N_2$  are closed subsets of  $N$  which are  $N$ -positively invariant;
- ii)  $K \in \text{int}(N_1 \setminus N_2)$ ;
- iii) If for some  $y \in N_1$  we find  $t_0 \in \mathbb{R}^+$  such that  $T(t_0)y \notin N$ , then there is  $\tau \in [0, t_0]$  for which  $T([0, \tau])y \subset N$  and  $S(\tau)y \in N_2$ .

Given  $Y \subset X$  and  $s \in \mathbb{R}^+$ , define the set

$$Y^s = \{x \in X : \text{there is } y \in Y \text{ with } T([0, s])y \subset Y \text{ and } T(s)y = x\}.$$

**Definition 2.1.23.** We say that a pair of sets  $\langle N_1, N_2 \rangle$  is a quasi-index pair in  $N$  if it satisfies:

- i) There are  $\tilde{N}_1 \subset X$  and  $t \in \mathbb{R}^+$  such that  $N_1 \setminus N_2 \subset \tilde{N}_1$ ,  $\tilde{N}_1^t \subset N_1$  and  $\langle \tilde{N}_1, N_2 \rangle$  is an index pair in  $N$ .
- ii) Either  $N_1$  is  $N$ -positively invariant or else there is  $M_1 \subset X$  which is a  $N \setminus N_2$ -positively invariant closed subset, with  $M_1 \setminus N_2 \subset \tilde{N}_1$  and  $M_1^s = N_1$ , for some  $s \in \mathbb{R}^+$ .

The existence of a quasi-index pair is assured in the case where  $N$  is an admissible set (see (RYBAKOWSKI, 1987)): for all sequences  $\{x_n\}_{n \in \mathbb{N}} \subset N$ ,  $\{t_n\}_{n \in \mathbb{N}} \subset \mathbb{R}^+$ ,  $t_n \rightarrow +\infty$ , satisfying  $T([0, t_n])x_n \in N$ , for all  $n \in \mathbb{N}$ , we find a convergent subsequence of  $\{T(t_n)x_n\}_{n \in \mathbb{N}}$ .

Given two closed subsets  $Y, A \subset X$ , we define the relation

$$\begin{aligned} x \in A \cap Y &\implies x \sim y, \text{ for all } y \in A \cap Y, \\ x \in Y \setminus A \text{ and } x \sim y &\iff y = x \end{aligned}$$

So, the pointed space

$$\left[ \frac{Y}{A}, [A] \right] = \{[y] : y \in Y \text{ and } [y] = \{x \in Y : x \sim y\}\}$$

is in fact a topological pointed space, with a topology induced by  $Y$ .

For an isolated invariant set  $K$  that admits an admissible neighborhood  $N$ , we define the Conley index  $I(K, S(\cdot))$  (or just  $I(K)$ ) as the topological space given by  $\left[ \frac{N_1}{N_2}, [N_2] \right]$ , for a quasi-index pair  $\langle N_1, N_2 \rangle$  in  $N$ . The concept is well-defined, see Theorem I.9.4 in (RYBAKOWSKI, 1987). The Conley index can be calculated in situations in which the Morse index cannot. But, when both are defined, they are related.

**Example 2.1.24.** Suppose that  $\phi$  is a hyperbolic equilibrium of a semigroup  $\{T(t) : t \geq 0\}$  and such that  $\dim W^u(\phi) = n$ ,  $n \in \mathbb{N}$ . Then we have

$$I(\{\phi\}) = S^n \text{ (the } n\text{-sphere).}$$

Another important characteristic of the Conley index is its continuation property. We will be more precise below.

Consider the family of semigroups  $\{T_\tau(t) : t \geq 0\}$ , for  $\tau \in [0, 1]$ . Define the set

$$\mathcal{F}(X) = \bigcup_{\tau \in [0, 1]} \{(K_\tau, T_\tau(\cdot)) : K_\tau \text{ is an isolated invariant set for } T_\tau(\cdot)\}.$$

**Definition 2.1.25.** A function  $\alpha : [0, 1] \rightarrow \mathcal{F}(X)$  is called  $\mathcal{F}$ -continuous if, for any  $\tau_0 \in [0, 1]$ , we find an open neighborhood  $W \subset [0, 1]$  of  $\tau_0$  and a closed set  $N \subset X$  such that:

- i) For any  $\tau \in W$ ,  $N$  is an isolating neighborhood for  $K_\tau$ , where  $K_\tau$  represents the largest invariant set in  $N$  under the action of  $\{T_\tau(t) : t \geq 0\}$ .
- ii) For all sequences  $\{\tau_n\}_{n \in \mathbb{N}} \subset W$  with  $\tau_n \rightarrow \tau_0$ ,  $\{t_n\}_{n \in \mathbb{N}} \subset \mathbb{R}^+$ ,  $t_n \rightarrow +\infty$ ,  $\{x_n\}_{n \in \mathbb{N}} \subset N$  with  $T_{\tau_n}([0, t_n])x_n \subset N$ ,  $n \in \mathbb{N}$ , the sequence  $\{T_{\tau_n}(t_n)x_n\}_{n \in \mathbb{N}}$  has a convergent subsequence.
- iii) Consider  $\{\tau_n\}_{n \in \mathbb{N}}$ ,  $\tau_0 \in [0, 1]$  with  $\tau_n \rightarrow \tau_0$ . Then, the family of semigroups  $\{T_{\tau_n}(t) : t \geq 0\}_{n \in \mathbb{N}}$  is continuous, that is, given  $\{t_n\}_{n \in \mathbb{N}}, t_0 \in \mathbb{R}^+$  and  $\{x_n\}_{n \in \mathbb{N}} \in \mathbb{N}, x_0$  with

$$t_n \rightarrow t_0 \text{ and } x_n \rightarrow x_0, \text{ as } n \rightarrow +\infty,$$

we have  $T_{\tau_n}(t_n)x_n \rightarrow T_{\tau_0}(t_0)x_0$  as  $n \rightarrow +\infty$ .

**Remark 2.1.26.** In our context, item ii) is satisfied if we assume for instance that  $\{T_\tau(t) : t \geq 0\}$ , for  $\tau \in [0, 1]$ , is collectively asymptotically compact.

One important characteristic of the Conley index is its continuation property.

**Theorem 2.1.27** (Theorem I.12.2, (RYBAKOWSKI, 1987)). Suppose that  $\alpha : [0, 1] \rightarrow \mathcal{F}(X)$  is  $\mathcal{F}$ -continuous. Then  $I(K_\tau, T_\tau(\cdot))$  is constant, for all  $\tau \in [0, 1]$ .

For our purposes, we need to present the concept of a connection matrix for a Morse decomposition. This theory was developed by Franzosa in (FRANZOSA, 1986; FRANZOSA, 1989). Later, the author also developed a concept of transition matrix, see (FRANZOSA, 1988; FRANZOSA; MISCHAIKOW, 1998). In essence, the connection and transition matrices appear as a topological approach in order to respond to whether there are connections between Morse sets in a Morse decomposition.

Consider a semigroup  $\{T(t) : t \geq 0\}$  and consider  $K$ , an isolated invariant set of  $X$ .

Suppose that we find a Morse decomposition  $\{M(\theta) : \theta \in P\}$  for some isolated set  $K$  under the action of  $\{T(t) : t \geq 0\}$ . The partial order  $<$  defined in  $P$  gives rise to what we call admissible order in  $K$ : we say that  $\theta < \theta'$  if  $M(\theta)$  appears before  $M(\theta')$  in the Morse decomposition. We say that a subset  $I \subset P$  is an interval if  $\theta', \theta'' \in I$  implies  $\theta \in I$ , for all  $\theta \in P$  with  $\theta'' < \theta < \theta'$ .

For  $\theta, \theta' \in P$ , we say  $\theta <_F \theta'$ , if there are  $\theta_j \in P$  and global solutions  $\xi_j : \mathbb{R} \rightarrow X$  such that

$$M(\theta_{j+1}) \overset{t \rightarrow -\infty}{\longleftarrow} \xi_j(t) \overset{t \rightarrow +\infty}{\longrightarrow} M(\theta_j), \quad 0 \leq j \leq n+1,$$

$\theta_0 = \theta$  and  $\theta_{n+1} = \theta'$ , for some  $n \in \mathbb{N}$ .

Now,  $<_F$  is called the flow order. Also, any admissible order is an extension of the flow order.

We will present the concept of connection matrix applied to our context. For more details on the general theory of connection matrices and the fact that we can specify it as we will do, see (FRANZOSA, 1989).

Consider a Morse decomposition  $\mathcal{M} = \{M(\pi) : \pi \in P\}$  related to a partial order  $<$ . Denote by  $\{H^*(\pi)\}_{\pi \in P}$  a collection of graded modules, where  $H^*(\pi)$  represents the homology chain of the  $\mathbb{Z}$ -modules associated to  $M(\pi)$ ,  $\pi \in P$ . Recall that the connection matrix is a linear map defined on the graded modules generated by the sum of the elements in  $\{H^*(\pi)\}_{\pi \in P}$  such that the homology index braid generated by  $\Delta$  is isomorphic to the homology index braid of the Morse decomposition. Hence, we define the linear map

$$\Delta : \bigoplus_{\pi \in P} H^*(\pi) \rightarrow \bigoplus_{\pi \in P} H^*(\pi),$$

which can be written as a matrix operator  $\Delta = (\Delta_{\pi, \pi'})_{\pi, \pi' \in P}$ . In (FRANZOSA, 1989) it is proved that such a connection matrix always exists. In addition, it satisfies the following properties:

- i)  $\Delta$  is an upper triangular matrix, that is,  $\Delta_{\pi, \pi'} = 0$  if  $\pi' < \pi$ .
- ii)  $\Delta$  is a boundary map, that is,  $\Delta^2 = 0$  and  $\Delta$  has degree  $-1$ .
- iii) If  $<$  is the flow order  $<_F$ ,  $\Delta_{\pi, \pi'} \neq 0$  and  $\{\pi, \pi'\}$  is an interval, there is a global solution  $\xi : \mathbb{R} \rightarrow X$  satisfying

$$M(\pi') \overset{t \rightarrow -\infty}{\longleftarrow} \xi(t) \overset{t \rightarrow +\infty}{\longrightarrow} M(\pi).$$

If we denote by  $\Delta_I$  the restriction of the map  $\Delta$  to any interval  $I$ , then all the above properties are also satisfied. In the sequel, we will always refer to a connection matrix related to the flow order.

Assume that  $Z$  is locally compact space and  $\Gamma$  is locally path connected.

**Definition 2.1.28** (Definition 4.1, (FRANZOSA, 1988)). A product parameterization of the local flow  $X \subset \Gamma$  is a homeomorphism  $\phi : Z \times \Gamma \rightarrow X$  such that for each  $\lambda \in \Gamma$ ,  $\phi(Z \times \{\lambda\})$  is a local flow.

We denote  $\phi|_{Z \times \{\lambda\}} = \phi_\lambda$  and its image by  $X_\lambda$ .

**Definition 2.1.29** (Definition 4.2, (FRANZOSA, 1988)). The space of isolated invariant sets for the product parameterization is the set

$$\mathcal{S} = \mathcal{S}(\phi) = \{(S_\lambda, X_\lambda) : S_\lambda \text{ is an isolated invariant set in } X_\lambda\}.$$

**Definition 2.1.30** (Definition 4.9, (FRANZOSA, 1988)). The space of Morse decompositions (indexed by  $P$ ) for the product parameterization  $\phi$  is the set

$$\mathcal{M}_P = \mathcal{M}_P(\phi) = \left\{ \prod_{\pi \in P} M_\lambda(\pi) \times S_\lambda \in \prod_P \mathcal{S}(\phi) \times \mathcal{S}(\phi) : \{M_\lambda(\pi)\}_{\pi \in P} \text{ is a Morse decomposition of } S_\lambda \right\}$$

with the topology inherited as a subspace of the product space  $\prod_P \mathcal{S}(\phi) \times \mathcal{S}(\phi)$ .

**Definition 2.1.31** (Definition 2.2, (FRANZOSA, 1988)). A  $<$ -ordered Morse decomposition of  $S$  is a collection  $M = M(S) = \{M(\pi)\}_{\pi \in P}$  of mutually disjoint compact invariant subsets of  $S$  such that if  $\gamma \in S \setminus \cup_{\pi \in P} M(\pi)$ , then there is  $\pi < \pi'$  with  $\gamma \in C(M(\pi'), M(\pi))$ .

**Definition 2.1.32** (Definition 4.10, (FRANZOSA, 1988)). The space of  $<$ -ordered Morse decompositions for the product parameterization  $\phi$  is the set

$$\mathcal{M}_< = \mathcal{M}_<(\phi) = \left\{ \prod_{\pi \in P} M_\lambda(\pi) \times S_\lambda \in \mathcal{M}_P : \{M_\lambda(\pi)\}_{\pi \in P} \text{ is a } < \text{-ordered Morse decomposition of } S_\lambda \right\}$$

with the topology inherited as a subspace of the product space  $\mathcal{M}_P$ .

**Definition 2.1.33** (Definition 4.15, (FRANZOSA, 1988)). Let  $M_\lambda = \{M_\lambda(\pi)\}_{\pi \in P}$  and  $M_\mu = \{M_\mu(\pi)\}_{\pi \in P}$  be Morse decompositions of isolated invariant sets  $S_\lambda \subset X_\lambda$  and  $S_\mu \subset X_\mu$ , respectively. We say that  $M_\lambda$  and  $M_\mu$  are related by continuation or are continuations of each other if there is a path  $c$  in  $\mathcal{M}_P$  from  $\prod_{\pi \in P} M_\lambda(\pi) \times S_\lambda$  to  $\prod_{\pi \in P} M_\mu(\pi) \times S_\mu$ . If, furthermore,  $M_\lambda$  and  $M_\mu$  are  $<$ -ordered and the path  $c$  is in  $M_\lambda$ , then we say that the associated admissible orderings are related by continuation or are continuations of each other.

**Theorem 2.1.34** (Theorem 5.5, (FRANZOSA, 1988)). If the admissible orderings  $<_\lambda$  of  $M_\lambda$  and  $<_\mu$  of  $M_\mu$  are related by continuation, then the set of connection matrix defined for  $\lambda$  and  $\mu$  are the same.

**Corollary 2.1.35.** (FRANZOSA, 1988, Corollary 5.6) If the flow ordering of  $M_\lambda$  is related by continuation to an admissible ordering of  $M_\mu$  then the set of connection matrices of  $M_\mu$  is a subset of the set of connection matrices of  $M_\lambda$ .

## 2.2 Non-autonomous problems

In this Section, we will be interested in studying the results for problems that have explicit dependency on the time-variable. We will have a new sense of invariance, which affects

our analysis. References for this section are (HENRY, 1981) and (CARVALHO; LANGA; ROBINSON, 2013).

**Definition 2.2.1.** An evolution process  $\{S(t, s) : (t, s) \in \mathcal{P}\} \subset C(X)$  is a family of maps that satisfies the following conditions:

- i)  $S(t, t) = I_X$ , for all  $t \in \mathbb{R}$ , where  $I_X$  denotes the identity map in  $C(X)$ ;
- ii)  $S(t, s)S(s, \tau) = S(t, \tau)$ , for all  $t, s, \tau \in \mathbb{R}$  with  $t \geq s \geq \tau$ ;
- iii)  $\mathcal{P} \times X \ni (t, s, x) \mapsto S(t, s)x \in X$  is a continuous map.

In order to further describe the results, we need to introduce the notions of pullback and uniform attractor for evolution processes.

**Definition 2.2.2.** We say that a family  $\{B(t) : t \in \mathbb{R}\}$  is positively (resp. negatively) invariant for the process  $\{S(t, s) : (t, s) \in \mathcal{P}\}$  if  $S(t, s)B(s) \subset B(t)$  (resp.  $B(t) \subset S(t, s)B(s)$ ), for all  $(t, s) \in \mathcal{P}$ .

We say that  $\{B(t) : t \in \mathbb{R}\}$  is invariant if  $S(t, s)B(s) = B(t)$ , for all  $(t, s) \in \mathcal{P}$ .

**Definition 2.2.3.** A family  $\{A(t) : t \in \mathbb{R}\} \subset X$  is the pullback attractor of  $\{S(t, s) : (t, s) \in \mathcal{P}\}$  if

- i)  $A(t)$  is compact, for each  $t \in \mathbb{R}$ ;
- ii)  $S(t, s)A(s) = A(t)$ , for all  $t \geq s$ ;
- iii) The family  $\{A(t) : t \in \mathbb{R}\}$  pullback attracts bounded sets of  $X$ , that is, for each bounded  $B \subset X$ , we have, for each  $t \in \mathbb{R}$ ,

$$\sup_{b \in B} \inf_{a \in A(t)} \|S(t, s)b - a\|_X \longrightarrow 0 \text{ as } s \rightarrow -\infty;$$

- iv)  $\{A(t) : t \in \mathbb{R}\}$  is the minimal family of closed sets that satisfies condition iii).

**Definition 2.2.4.** A set  $\mathbf{A}$  is the uniform attractor of  $\{S(t, s) : (t, s) \in \mathcal{P}\}$  if it is a compact subset of  $X$  with the property that

$$\sup_{\tau \in \mathbb{R}} \sup_{b \in B} \inf_{\mathbf{a} \in \mathbf{A}} \|S(t + \tau, \tau)b - \mathbf{a}\|_X \xrightarrow{t \rightarrow \infty} 0$$

for any  $B \subset X$  bounded.

For more details about evolution processes and their attractors, see (CARVALHO; LANGA; ROBINSON, 2013).

A global solution of the process  $\{S(t, s) : (t, s) \in \mathcal{P}\}$  is a function  $\xi : \mathbb{R} \rightarrow X$  such that  $S(t, s)\xi(s) = \xi(t)$ ,  $\forall (t, s) \in \mathcal{P}$ . Additionally,  $\xi$  is called a bounded solution if the set  $\{\xi(t) : t \in \mathbb{R}\}$  is bounded in  $H_0^1(0, \pi)$ .



If we assume that  $\bigcup_{s \in \mathbb{R}} A(s)$  is bounded in  $X$ , then we have the following characterization for the pullback attractor:

$$A(t) = \{ \xi(t) : \xi : \mathbb{R} \rightarrow X \text{ is a bounded global solution of } \{S(\cdot, \cdot)\} \}.$$

**Definition 2.2.5.** Let  $\{S(t, s) : t \geq s\}$  be a semigroup and consider a bounded set  $B \subset X$ . For  $t \in \mathbb{R}$ , we define the  $\omega$ -limit of  $B$  at time  $t$  as the set

$$\omega(B, t) = \bigcap_{s \leq t} \overline{\bigcup_{r \leq s} S(t, r)B}.$$

**Definition 2.2.6.** Consider an invariant family  $\{B(t) : t \in \mathbb{R}\}$  of  $S(\cdot, \cdot)$ . We define the unstable set of  $E(\cdot)$  as the family  $\{W^u(B(\cdot))(t) : t \in \mathbb{R}\}$ , where  $W^u(B(\cdot))(t) = \{x \in \mathbb{R} : \text{there is a solution } \eta : \mathbb{R} \rightarrow X \text{ of } S(\cdot, \cdot) \text{ with } \eta(t) = x \text{ and } d(\eta(s), B(s)) \rightarrow 0 \text{ as } s \rightarrow -\infty\}$ .

In the conditions above, if the invariant family is bounded and the process  $S(\cdot, \cdot)$  admits a pullback-attractor  $\{A(t) : t \in \mathbb{R}\}$ , then  $W^u(B(\cdot))(t) \subset A(t)$ , for all  $t \in \mathbb{R}$ .

**Definition 2.2.7.** A set  $D \subset X$  pullback absorbs bounded sets a time  $t \in \mathbb{R}$  if given a bounded set  $B \subset X$  we find  $s_B < t$  such that  $S(t, s)B \subset D$ , for all  $s \leq s_B$ .

**Definition 2.2.8.** We say that a process  $\{S(t, s) : (t, s) \in \mathcal{P}\}$  is pullback asymptotically compact if, for any  $t \in \mathbb{R}$ , and sequence  $\{s_n\}_{n \in \mathbb{N}} \in \mathbb{R}$ , with  $t \geq s_n \rightarrow -\infty$ , and a bounded set  $\{x_n\}_{n \in \mathbb{N}} \in X$ , we have the sequence  $\{S(t, s_n)x_n\}_{n \in \mathbb{N}}$  has a convergent subsequence.

**Definition 2.2.9.** A process  $\{S(t, s) : (t, s) \in \mathcal{P}\}$  is strongly pullback asymptotically compact if: for each  $t \in \mathbb{R}$  and sequences  $\{s_n\}_{n \in \mathbb{N}}, \{\tau_n\}_{n \in \mathbb{N}}$ , with  $t \geq \tau_n \geq s_n$  and  $\tau_n - s_n \rightarrow +\infty$  as  $n \rightarrow +\infty$ , and a bounded sequence  $\{x_n\}_{n \in \mathbb{N}} \in X$ , it follows that the sequence  $\{S(\tau_n, s_n)x_n\}_{n \in \mathbb{N}}$  has a convergent subsequence.

**Theorem 2.2.10.** Suppose that a process  $\{S(t, s) : (t, s) \in \mathcal{P}\}$  can be written as

$$S(t, s) = L(t, s) + U(t, s), \text{ for all } (t, s) \in \mathcal{P},$$

with the following properties:

- i) there is a function  $k : \mathbb{R}^+ \times \mathbb{R}^+ \rightarrow \mathbb{R}$  where, for each  $r > 0$ ,  $k(\cdot, r)$  is non-increasing and  $k(\sigma, r) \rightarrow 0$  as  $\sigma \rightarrow +\infty$  and for  $x \in B_X(0, r)$ ,

$$\|L(t, s)x\| \leq k(t - s, r), \text{ for all } (t, s) \in \mathcal{P}.$$

- ii)  $\{U(t, s) : t \geq s\}$  is a strongly compact family of continuous maps (not necessarily a process): for each  $t \in \mathbb{R}$  and bounded set  $B \subset X$ , we find a constant  $T_B \geq 0$  and a compact set  $K \subset X$ , for which

$$U(\tau, s)B \subset K,$$

as long as  $s \leq \tau \leq t$  and  $\tau - s \geq T_B$ .



In these conditions, the process  $\{S(t, s) : (t, s) \in \mathcal{P}\}$  is strongly pullback asymptotically compact.

**Definition 2.2.11.** A process  $\{S(t, s) : (t, s) \in \mathcal{P}\}$  is strongly pullback bounded dissipative if there is a family of bounded sets  $\{B(t) : t \in \mathbb{R}\}$  that pullback attracts bounded sets of  $X$ . In other words, if we consider  $t \in \mathbb{R}$ , for each  $\tau \leq t$  and bounded set  $D \subset X$ , we have

$$\lim_{s \rightarrow -\infty} \sup_{x \in D} d(S(\tau, s)x, B(t)) = 0.$$

**Theorem 2.2.12.** Suppose that a process  $\{S(t, s) : t \geq s\}$  is pullback asymptotically compact and strongly pullback bounded dissipative. Let  $\{B(t) : t \in \mathbb{R}\}$  be the family of bounded sets that pullback attracts bounded sets of  $X$ .

In this conditions,  $\{S(t, s) : t \geq s\}$  has a pullback attractor  $\{\mathcal{A}(t) : t \in \mathbb{R}\}$  and, for each  $t \in \mathbb{R}$ ,  $\mathcal{A}(t) = \omega(\overline{B(t)}, t)$ .

Additionally, for each  $t \in \mathbb{R}$ , the set  $\bigcup_{s \leq t} \mathcal{A}(s)$  is bounded in  $X$ .

## 2.3 Semilinear problems

Consider the problem

$$\begin{cases} \dot{x} = Ax + f(t, x) \\ x(0) = x_0 \end{cases}$$

for  $A : D(A) \subset X \rightarrow X$  a linear operator and  $f \in C^1(U, X)$ , for a subset  $U \subset \mathbb{R}^+ \times X$ . We will study conditions for which the problem above admits a process with a pullback attractor.

### 2.3.1 The linear theory

Before that, let us define the concept of resolvent and spectrum of a linear operator  $A$ . Denote the set  $R(A) = \{Ax \in X : x \in D(A)\}$  and we called it the image of  $A$ . Also, denote by  $A^{-1}$  the inverse of  $A$ , if it exists. If  $\overline{D(A)} = X$  (the closure of  $D(A)$  is equal to  $X$ ), we say that  $A$  is densely defined.

We define the resolvent of  $A$ ,  $\rho(A)$ , as the set

$$\left\{ \lambda \in \mathbb{C} : \lambda - A \text{ is injective, } \overline{R(\lambda - A)} = X \text{ and } (\lambda - A)^{-1} : R(\lambda - A) \subset X \rightarrow D(A) \text{ is bounded} \right\}.$$

The set  $\sigma(A) = \mathbb{C} \setminus \rho(A)$  is called the spectrum of  $A$ .

Suppose that  $A$  is a closed operator, that is, given a sequence  $x_n \in D(A)$  and points  $x, y \in X$  such that  $x_n \rightarrow x$  and  $Ax_n \rightarrow y$ , we find  $x \in D(A)$  and  $y = Ax$ . In this case, the spectrum can be divided in three distinct types  $\sigma(A) = \sigma_p(A) \cup \sigma_r(A) \cup \sigma_c(A)$ , which are

- The set  $\sigma_p(A)$  is called the point spectrum and it is given by the set of eigenvalues of  $A$ , that is,

$$\sigma_p(A) = \{\lambda \in \mathbb{C} : \lambda - A \text{ is not injective}\}$$

- The residual spectrum is the set

$$\sigma_r(A) = \{\lambda \in \mathbb{C} : \lambda - A \text{ is injective and } \overline{R(\lambda - A)} \neq X\}$$

- The continuous spectrum is given by

$$\sigma_c(A) = \{\lambda \in \mathbb{C} : \lambda - A \text{ is injective, } \overline{R(\lambda - A)} = X \text{ but } (\lambda - A)^{-1} \text{ is not bounded}\}.$$

**Definition 2.3.1.** We say that a linear operator  $A : D(A) \subset X \rightarrow X$  has compact resolvent if we find  $\lambda_0 \in \rho(A)$  for which  $(\lambda_0 - A)^{-1}$  is a compact operator. In other words,  $(\lambda_0 - A)^{-1}B_X(0, 1)$  is relatively compact, where  $B_X(0, 1)$  represents the ball in  $X$  centered at 0 and with radius 1.

**Definition 2.3.2.** A linear operator  $A : D(A) \subset X \rightarrow X$  is said to be of positive type with constant  $M \geq 1$  if it is closed, densely defined and such that, for all  $s \in \mathbb{R}^+$  we have  $s \in \rho(-A)$ , with

$$\|(s + A)^{-1}\| \leq \frac{M}{1 + s}.$$

**Definition 2.3.3.** Consider  $A : D(A) \subset X \rightarrow X$ . We say that  $-A$  is sectorial if there are constants  $M \in \mathbb{R}^+$ ,  $\theta \in (\frac{\pi}{2}, \pi)$  such that  $\Sigma_\theta = \{\lambda \in \mathbb{C} : |\arg(\lambda)| \leq \theta\} \cup \{0\} \subset \rho(A)$  and, for all  $\lambda \in \Sigma_\theta$ , we have that

$$\|(\lambda - A)^{-1}\|_{\mathcal{L}(X)} \leq \frac{M}{|\lambda| + 1}.$$

It can be shown that any positive operator  $A$  is also sectorial, see Remark 1.3.3 in (CHOLEWA; DLOTKO, 2000). Therefore, we can find a sector  $\Sigma$  inside  $\rho(A)$ .

Suppose that  $A$  is sectorial. Since  $\{0\} \in \rho(A)$  and the resolvent of  $A$  is open, we can find  $r > 0$  such that  $B_X(0, r) \subset \rho(A)$ . Now, consider the curve  $\Gamma$  defined by the boundary of  $\Sigma_\theta \setminus B_X(0, r)$  oriented in a way that the imaginary part is increasing, as in the Figure 2.

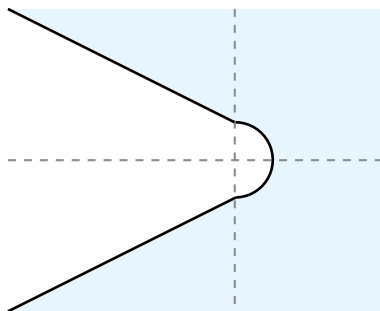

Figure 2 – Example of a curve  $\Gamma$ .

Then, for each  $\alpha \in \mathbb{C}$ , with  $\text{Re}\alpha < 0$  (Real part of  $\alpha$  less than 0), we may define the operator

$$A^\alpha = \frac{1}{2\pi i} \int_{\Gamma} (-\lambda)^\alpha (\lambda + A)^{-1} d\lambda.$$

We do not intend to profoundly explore the operators  $A^\alpha$ , with  $\text{Re}\alpha < 0$ , but we will summarize some of the well-known problems of the operators. One can find the proof of these properties in (HENRY, 1981).

**Lemma 2.3.4.** (i) For  $\alpha, \beta \in \mathbb{C}$  with  $\operatorname{Re}\alpha, \operatorname{Re}\beta < 0$  we have  $A^\alpha A^\beta = A^{\alpha+\beta}$ .

(ii) For each  $\alpha \in \mathbb{C}$ , with  $\operatorname{Re}\alpha < 0$ , the operator  $A^\alpha$  is injective.

As a consequence of the lemma, for  $\beta \in \mathbb{C}$ , with  $\operatorname{Re}\beta > 0$  we are able to define  $A^\beta : D(A^\beta) \subset X \rightarrow X$ , where  $D(A^\beta) = R(A^{-\beta})$  and

$$A^\beta u = (A^{-\beta})^{-1}u, \text{ for all } u \in D(A^\beta).$$

We can define a norm in  $D(A^\alpha)$  given by  $\|u\|_\alpha := \|A^\alpha u\|_X$ .

**Definition 2.3.5.** We define the space of fractional power of  $A$  as  $X^\alpha := (D(A^\alpha), \|\cdot\|_\alpha)$ , for  $\alpha \in \mathbb{C}$ ,  $\operatorname{Re}\alpha > 0$ .

The spaces of fractional powers develop an essential role in the proof of existence of solutions for a semilinear problem (with a positive operator  $A$  as its principal part) and also the regularity of such solutions. Useful properties are described in the below theorem.

**Theorem 2.3.6.** The fractional powers of the operator  $A$  satisfies the following properties:

(i) If  $\alpha, \beta \in \mathbb{C}$ ,  $\operatorname{Re}\alpha, \operatorname{Re}\beta > 0$ , then  $A^\alpha A^\beta = A^{\alpha+\beta}$ .

(ii) For  $\alpha, \beta \in \mathbb{C}$ , with  $\operatorname{Re}\beta > \operatorname{Re}\alpha > 0$ , we have  $D(A^\beta) \subset D(A^\alpha)$  and the space of fractional powers satisfies

$$X^\beta \hookrightarrow X^\alpha \hookrightarrow X,$$

where the symbol “ $\hookrightarrow$ ” represents a continuous inclusion.

Moreover,  $X^\beta$  is also dense in  $X^\alpha$ .

(iii) Additionally, if  $A$  has a compact resolvent, then the inclusions above are compact.

**Theorem 2.3.7.** Suppose that  $A : D(A) \subset X \rightarrow X$  is a densely defined sectorial operator. Then  $-A$  generates a strongly continuous semigroup  $\{e^{-At} : t \geq 0\}$ , that is,  $\{e^{-At} : t \geq 0\}$  is a semigroup for which  $\lim_{t \rightarrow 0^+} e^{-At}x = x$ , for all  $x \in X$ .

**Theorem 2.3.8.** Suppose that  $A$  is a sectorial operator and consider  $\omega \in (0, \operatorname{Re}\sigma(A))$ . Then we find  $M > 0$  such that

$$\begin{aligned} \|e^{-At}u\| &\leq M e^{-\omega t} \|u\|, \text{ for all } t > 0 \text{ and } u \in X, \\ \|e^{-At}u\|_{X^\gamma} &\leq M t^{-\gamma} e^{-\omega t} \|u\|, \text{ for all } t > 0 \text{ and } u \in X. \end{aligned} \tag{2.1}$$

**Theorem 2.3.9.** Suppose  $A : D(A) \subset X \rightarrow X$  is a densely defined sectorial operator which has compact resolvent. Then the following is valid:

i) For  $t > 0$  such that the operator  $e^{-At}$  is a compact;

ii) For all  $t \geq 0$ ,  $\sigma(e^{-At}) \setminus \{0\} = e^{t\sigma(-A)} = e^{t\sigma_p(-A)}$ .

The above theorem is a consequence of Theorems 3.13.2 and 6.2.2 in (CARVALHO, 2017).

**Theorem 2.3.10.** Consider a strongly continuous semigroup  $\{T(t) : t \geq 0\} \subset L(X)$ . Suppose that, for some  $t_0, \alpha \in \mathbb{R}^+$ ,  $\sigma(T(t_0)) \cap \{\lambda \in \mathbb{C} : |\lambda| = e^{\alpha t_0}\} = \emptyset$ . Then, there is a projection  $P \in L(X)$ ,  $P^2 = P$ ,  $PT(t) = T(t)P$  for all  $t \geq 0$ , such that for  $X_- = R(P)$  and  $X_+ = N(P)$ , the restrictions  $T(t)|_{X_{\pm}}$  are in  $L(X_{\pm})$  and

$$\begin{aligned}\sigma(T(t)|_{X_-}) &= \sigma(T(t)) \cap \{\lambda \in \mathbb{C} : |\lambda| < e^{\alpha t}\} \text{ and} \\ \sigma(T(t)|_{X_+}) &= \sigma(T(t)) \cap \{\lambda \in \mathbb{C} : |\lambda| > e^{\alpha t}\}.\end{aligned}$$

Moreover, there are  $M \geq 1$ ,  $\delta > 0$  such that

$$\|T(t)|_{X_-}\|_{L(X_-)} \leq Me^{(\alpha-\delta)t}, \quad \forall t \geq 0;$$

$\{T(t)|_{X_+} : t \geq 0\}$  can be extended by a group in  $L(X_+)$ ,  $T(t)|_{X_+} = (T(-t)|_{X_+})^{-1}$  for  $t < 0$ , and

$$\|T(t)|_{X_+}\|_{L(X_+)} \leq Me^{(\alpha+\delta)t}, \quad \forall t \leq 0.$$

For the proof of the above theorem, see (HENRY, 1981, Theorem I 19.2) or (CARVALHO, 2017, Theorem 6.1.1).

**Remark 2.3.11.** Suppose that we are in the conditions of Theorem 2.3.9 and that  $\sigma(A) \cap \{\lambda \in \mathbb{C} : \operatorname{Re} \lambda = 0\} = \emptyset$ . By Theorem 2.3.9, it follows that  $\sigma(e^A) \cap \{\lambda \in \mathbb{C} : |\lambda| = 1\} = \emptyset$ . Thus,  $\{e^{-At} : t \geq 0\}$  satisfies the conditions of Theorem 2.3.10 for  $t_0 = 1$  and  $\alpha = 0$ . Therefore, there exists a projection  $P \in L(X)$  and constants  $M \geq 1$  and  $\delta > 0$  such that

$$\begin{aligned}\|e^{-At}(I-P)\|_{L(X)} &\leq Me^{-\delta t}, \text{ for } t \geq 0, \\ \|e^{-At}P\|_{L(X)} &\leq Me^{\delta t}, \text{ for } t < 0.\end{aligned}$$

In this thesis, we will usually work with semilinear problems with principal part given by the Laplacian operator defined on  $H^2(0, \pi) \cap H_0^1(0, \pi) \subset L^2(0, \pi)$ . In the example below we will present properties of such operators.

**Example 2.3.12.** Consider  $A : D(A) \subset L^2(0, \pi) \rightarrow L^2(0, \pi)$  the operator given by  $Au = u_{xx}$ , for  $u \in D(A) = H^2(0, \pi) \cap H_0^1(0, \pi)$ .

Define the problem

$$\begin{cases} u_t = Au, & x \in (0, \pi), t > 0, \\ u(t, 0) = u(t, \pi) = 0, & t \geq 0, \\ u(0, \cdot) = u_0 \in H_0^1(0, \pi). \end{cases}$$

The operator  $-A$  is sectorial with  $(0, +\infty) \subset \rho(A)$ . Also, the operator  $-A$  has positive resolvent, that is, for all element  $u_0 \in L^2(0, \pi)$  with  $u_0 \geq 0$  we have

$$(\lambda + A)^{-1}u_0 \geq 0, \quad \forall \lambda > 0.$$

The above problem defines a semigroup  $\{e^{At} : t \geq 0\} \subset \mathcal{L}(X)$ , for  $X = L^2(0, \pi)$ . We can consider  $X^\gamma$ ,  $\gamma \in (0, 1]$ , as the fractional powers defined by  $-A$  (see Section 6.4.2, (CARVALHO; LANGA; ROBINSON, 2013), for more details). We also have the following inequalities:

$$\begin{aligned} \|e^{At}u\|_{X^\gamma} &\leq e^{-t}\|u\|_{X^\gamma}, \text{ for all } t \geq 0, \\ \|e^{At}u\|_{X^\gamma} &\leq t^{-\gamma}e^{-t}\|u\|, \text{ for all } t \geq 0. \end{aligned} \quad (2.2)$$

For the Laplacian operator, we can also describe  $X^\alpha$ , for  $\alpha \in (0, 1) \setminus \{1/2\}$ , using interpolation theory, see (TRIEBEL, 1995).

### 2.3.2 Existence of solution for the semilinear problem

Here, we will explore the properties that we need to ask in order to find solutions for the problem

$$\begin{cases} \dot{x} = Ax + f(t, x) \\ x(0) = x_0 \end{cases}. \quad (2.3)$$

We will consider (2.3) satisfying the conditions:

- 1)  $-A$  is a sectorial operator. Then we can define the fractional power spaces of  $A$ ,  $\{(X^\alpha, \|\cdot\|_\alpha) : \alpha > 0\}$ .
- 2) Let  $\alpha \in [0, 1)$ . We assume

$$f : \mathbb{R} \times X^\alpha \rightarrow X$$

is Hölder continuous in the variable  $t$  and locally Lipschitz continuous in the  $x$ -variable.

That is, for each  $B \subset \mathbb{R} \times X^\alpha$ , there is  $C = C(B) > 0$  and  $\theta > 0$  such that

$$\|f(t, x) - f(s, y)\| \leq C(|t - s|^\theta + \|x - y\|_\alpha),$$

for  $(t, x), (s, y) \in B$ .

In this section, we will present the basic definitions and results that allow us to study semigroups. If not said otherwise, the results presented here, such as their demonstrations, were taken from (HENRY, 1981).

**Definition 2.3.13.** (HENRY, 1981, Definition 3.3.1) We say that  $x : [t_0, t_1) \rightarrow X^1$ ,  $t_1 > t_0$ , is a solution of (2.3) if  $x(t_0) = x_0$  and for  $t \in (t_0, t_1)$  we have  $x(t) \in D(A)$ ,  $\frac{dx}{dt}(t)$  exists and the functions  $t \mapsto f(t, x(t))$  is locally Hölder continuous and  $\int_{t_0}^{t_0+\delta} \|f(t, x(t))\| dt < \infty$  for some  $\delta > 0$  and  $x(\cdot)$  satisfies (2.3).

**Definition 2.3.14.** We say that  $x : [t_0, t_1] \rightarrow X^\alpha$ ,  $t_1 > t_0$ , is a mild solution of (2.3) if  $x(t_0) = x_0$ ,  $x \in C([t_0, t_1], X^\alpha)$  and for  $t \in (t_0, t_1)$ ,  $x(t)$  satisfies the variation of constants formula

$$x(t) = e^{A(t-t_0)x_0} + \int_{t_0}^t e^{A(t-s)} f(s, x(s)) ds.$$

The relation between the definitions are given in the following result.

**Lemma 2.3.15.** Consider  $x \in C([t_0, t_1], X^\alpha)$ . Suppose that, for some  $\delta > 0$ ,  $\int_{t_0}^{t_0+\delta} \|f(t, x(t))\| dt < +\infty$ . Under these conditions, if  $x(\cdot)$  is a mild solution, then  $x(\cdot)$  is a solution.

See (HENRY, 1981, Lemma 3.3.2) for the proof of the above lemma.

**Lemma 2.3.16** (Singular Gronwall Lemma). Suppose that we have a function  $u \in L^1(0, +\infty, \mathbb{R}^+)$  that satisfies the following inequality almost for all  $t \in \mathbb{R}^+$

$$u(t) \leq c + d \int_0^t (t-s)^{-\alpha} u(s) ds$$

for  $c, d \in (0, +\infty)$ ,  $\alpha \in [0, 1)$ . Then, for some constant  $K \in \mathbb{R}^+$  we have

$$u(t) \leq 2ce^{Kt},$$

for almost all  $t \in \mathbb{R}^+$ . We can express the value of  $K = (2d\Gamma(1-\alpha))^{\frac{1}{1-\alpha}}$ .

**Theorem 2.3.17.** Consider the problem (2.3). We have the following:

- (i) For each  $(t_0, x_0) \in \mathbb{R}^+ \times X^\alpha$ , there is a  $\tau > t_0$  and a solution  $x : [t_0, \tau] \rightarrow X$  of (2.3) satisfying  $x(t_0) = x_0$ .
- (ii) If there are two solutions  $x_{(j)} : [t_0, \tau_j] \rightarrow X$  of (2.3), with  $x_{(j)}(t_0) = x_0$ ,  $j = 1, 2$ , then we have  $x_{(1)}(t) = x_{(2)}(t)$ , for  $t \in [0, \min\{\tau_1, \tau_2\})$ . Consequently, for each  $(t_0, x_0) \in \mathbb{R}^+ \times X^\alpha$ , there is a maximal solution of (2.3)

*Proof.* Let  $(t_0, u_0) \in \mathbb{R}^+ \times X^\alpha$ . For  $T > t_0$  and  $R > 0$ , define the space  $\mathcal{B} \subset (C([t_0, T]; X^\alpha), \|\cdot\|)$ , where  $\|\cdot\| := \sup_{t \in [t_0, T]} \|u\|_{X^\alpha}$ , satisfying  $\|u - u_0\| \leq R$  for  $u \in \mathcal{B}$ . It is easy to see that  $(\mathcal{B}, \|\cdot\|)$  is a complete metric space.

Define the function  $\mathcal{G} : \mathcal{B} \rightarrow \mathcal{B}$  by

$$\mathcal{G}(u)(t) = e^{A(t-t_0)} u_0 + \int_{t_0}^t e^{A(t-s)} f(s, u(s)) ds, \quad t \in [t_0, T].$$

We want to show that choose  $T - t_0$  sufficiently small such that  $\mathcal{G}$  defines a contraction. Denote  $B = \sup_{t \in [t_0, T]} \|f(t, u_0)\|$ . Since  $A$  is sectorial, we find  $M, \omega > 0$  as in (2.1).

Let  $u(\cdot) \in \mathcal{B}$ . We can see using the continuity of the variation of constant formula that  $\mathcal{G}(u)(\cdot) \in C([t_0, T], X^\alpha)$ . Now, for  $t \in [t_0, T]$ ,

$$\begin{aligned}
\|\mathcal{G}(u)(t) - u_0\|_{X^\alpha} &\leq \| [e^{A(t-t_0)} - I]u_0 \|_{X^\alpha} + \int_{t_0}^t \| e^{A(t-s)} f(s, u_0) \|_{X^\alpha} ds \\
&\quad + \int_{t_0}^t \| e^{A(t-s)} [f(s, u(s)) - f(s, u_0)] \|_{X^\alpha} ds \\
&\leq M e^{-\omega t} \| [e^{A(t-t_0)} - I]u_0 \|_{X^\alpha} + M B \int_{t_0}^t e^{-\omega(t-s)} (t-s)^{-\alpha} ds \\
&\quad + \int_{t_0}^t e^{-\omega(t-s)} (t-s)^{-\alpha} \| f(s, u(s)) - f(s, u_0) \| ds \\
&\leq M e^{-\omega t} \| [e^{A(t-t_0)} - I]u_0 \|_{X^\alpha} + M B \int_{t_0}^t e^{-\omega(t-s)} (t-s)^{-\alpha} ds \\
&\quad + M C \int_{t_0}^t e^{-\omega(t-s)} (t-s)^{-\alpha} \| u(s) - u_0 \|_{X^\alpha} ds \\
&\leq M e^{-\omega t_0} \| [e^{A(t-t_0)} - I]u_0 \|_{X^\alpha} + M(B + CR) (T - t_0)^{1-\alpha} \int_0^1 e^{-\omega r} r^{-\alpha} dr.
\end{aligned}$$

We may assume that  $T - t_0$  was chosen small enough so that  $\|\mathcal{G}(u)(t) - u_0\|_{X^\alpha} \leq R$ , for all  $t \in [t_0, T]$ . In this condition,  $\mathcal{G}$  maps  $\mathcal{B}$  to itself.

Now, consider  $u, v \in \mathcal{C}$  and  $t \in [t_0, T]$ . We have the following

$$\begin{aligned}
\|\mathcal{G}(u)(t) - \mathcal{G}(v)(t)\|_{X^\alpha} &\leq \int_{t_0}^t \| e^{A(t-s)} [f(s, u(s)) - f(s, v(s))] \|_{X^\alpha} ds \\
&\leq M \int_{t_0}^t e^{-\omega(t-s)} (t-s)^{-\alpha} \| f(s, u(s)) - f(s, v(s)) \| ds \quad (2.4) \\
&\leq \left( M C \int_{t_0}^t e^{-\omega(t-s)} (t-s)^{-\alpha} ds \right) \| \|u - v\| \|
\end{aligned}$$

Now, we may also assume that  $T - t_0$  is chosen small enough such that  $M C \int_{t_0}^t e^{-\omega(t-s)} (t-s)^{-\alpha} ds \leq \nu < 1$  and then

$$\| \|\mathcal{G}(u) - \mathcal{G}(v)\| \| \leq \nu \| \|u - v\| \|.$$

Hence,  $\mathcal{G}$  defines a contraction map from  $\mathcal{B}$  to itself. As a consequence, there is a  $u \in \mathcal{B}$  with  $\mathcal{G}(u) = u$ . By Lemma 2.3.15,  $u$  is a solution of (2.3) and item i) is proved.

Observe that item ii) is also valid as a consequence of construction of solutions in terms of fixed points from a contraction map.  $\square$

The above results assure that for  $(t_0, x_0) \in U$  we can define

$$\tau_{max} = \tau_{max}(t_0, x_0) = \sup\{ \tau > t_0 : \text{there is } x : [t_0, \tau] \rightarrow X \text{ with } x(t_0) = x_0 \}.$$

So, for each  $n \in \mathbb{N}$ , we can find a solution  $x_{(n)} : [t_0, \tau_n] \rightarrow X$  with  $x_{(n)}(t_0) = x_0$ , such that  $t_0 < \tau_n \rightarrow \tau_{max}$  as  $n \rightarrow +\infty$ . Then, we define the maximal solution  $x^* : [t_0, \tau_{max}) \rightarrow X$  as  $x^*(t) = x_{(n)}(t)$ , if  $t \in [t_0, \tau_n)$ .

**Theorem 2.3.18.** In the conditions of the above Theorem, we have the following: For each  $(t_0, x_0) \in U$ , if its maximal solution is bounded, it follows that  $\tau_{max} = +\infty$ .

**Theorem 2.3.19.** (HENRY, 1981, Corollary 3.3. 5) Suppose that, for  $\tau \in \mathbb{R}$ ,  $f$  is Holder continuous in  $t$  and Locally Lipschitz in the second variable. Additionally,  $f$  satisfies the following

$$\|f(t, x)\| \leq K(t)(1 + \|x\|^\alpha), \quad t \in (\tau, +\infty)$$

where  $K(\cdot)$  is continuous on  $(\tau, +\infty)$ . Then, for any  $t_0 \in (\tau, +\infty)$  and  $u_0 \in X^\alpha$ , it follows that  $u(\cdot, t_0, u_0)$  exists for all time greater than  $t_0$ .

Suppose that for a semilinear problem as (2.3) we have the global existence and the continuity of initial data. If  $u(\cdot, s, u_0)$  denotes the solution of (2.3) that passes through  $u_0$  at the time  $s$ , we can define a process  $\{S(t, s) : t \geq s\}$  given by  $S(t, s)u_0 = u(t, s, u_0)$ , for  $t \geq s$ .

### 2.3.3 Comparison results

Usually, it is relevant for the asymptotic analysis of solutions to compare a problem to another one. This is possible for some semilinear problem defined in a Banach ordered space. We decided to present the results restrict to the ordered space  $X = H_0^1(0, \pi)$  or  $X = L^p(0, \pi)$ ,  $p \in [2, +\infty]$ , which admit the following partial ordering

$$u \geq v \text{ in } X \Leftrightarrow u(x) \geq v(x) \text{ a. e. for } x \in (0, \pi).$$

Denote by  $\mathcal{C}_X = \{u \in X : u \geq 0\}$ , the associated positive cone and by  $B_X(0, r)$  the open ball of radius  $r$  around 0 in  $X$ .

We consider the following problem

$$\begin{cases} \dot{u} = Au + z(t, u), & t > s, \\ u(s) = u_0(\cdot) \in H_0^1(0, \pi) \end{cases} \quad (2.5)$$

where

- (1)  $A : D(A) \subset L^2(0, \pi) \longrightarrow L^2(0, \pi)$  is the linear operator defined in  $D(A) = H^2(0, \pi) \cap H_0^1(0, \pi)$  and given by  $Au = u_{xx}$ ,  $u \in D(A)$ .
- (2) The nonlinearity  $z : \mathbb{R} \times H_0^1(0, \pi) \longrightarrow L^2(0, \pi)$  satisfies: For each  $r > 0$  there exists  $\gamma(r) > 0$  such that, for all  $t \in [t_0, t_1]$  and  $u \in \mathcal{C}_{H_0^1(0, \pi)} \cap B_{H_0^1(0, \pi)}(0, r)$ ,  $\gamma u + z(t, u)$  is positive.

Denote by  $u_z(t, s, u_0)$  the solution of (2.5) at the time  $t \geq s$ . The following theorem provides the comparison result that we are seeking.

**Theorem 2.3.20.** (CARVALHO; LANGA; ROBINSON, 2013, Theorem 6.41) Consider a linear operator  $A$  as above and the problem (2.5) for  $z = f, g, h$ , functions that satisfy (2).



- (i) If for every  $r > 0$  there is a constant  $\gamma = \gamma(r) > 0$  such that  $f(t, \cdot) + \gamma I$  is increasing in  $B_{H_0^1(0, \pi)}(0, r)$ , for all  $t \in [s, t_1]$  and  $u_0, u_1 \in H_0^1(0, \pi)$  with  $u_0 \geq u_1$ , then  $u_f(t, s, u_0) \geq u_f(t, s, u_1)$  as long as both solutions exist.
- (ii) If  $f(t, \cdot) \geq g(t, \cdot)$  for all  $t \in \mathbb{R}$  and  $u_0 \in H_0^1(0, \pi)$  then  $u_f(t, s, u_0) \geq u_g(t, s, u_0)$  as long as both solutions exist.
- (iii) If  $f, g$  are such that for every  $r > 0$  there exist a constant  $\gamma = \gamma(r) > 0$  and an increasing function  $h(t, \cdot)$  such that, for every  $t \in [s, t_1]$

$$f(t, \cdot) + \gamma I \geq h(t, \cdot) \geq g(t, \cdot) + \gamma I$$

in  $B_{H_0^1(0, \pi)}(0, r)$  and  $u_0, u_1 \in H_0^1(0, \pi)$  with  $u_0 \geq u_1$ , then  $u_f(t, s, u_0) \geq u_g(t, s, u_1)$  as long as both exist.

This comparison result will be necessary to show the existence of special non-autonomous solutions for a non-autonomous problem in Chapter 4.

**Definition 2.3.21.** A global solution  $\xi : \mathbb{R} \rightarrow H_0^1(0, \pi)$  of  $\{S(t, s) : (t, s) \in \mathcal{P}\}$  is a non-autonomous equilibrium if the zeros of  $\xi(t)$  are finite and are the same for all  $t \in \mathbb{R}$ ; also,  $\xi$  is non-degenerate as  $t \rightarrow \pm\infty$ , that is, we can find  $\phi \in H_0^1(0, \pi)$  such that  $|\xi(t)(x)| \geq \phi(x) > 0$ , for all  $t \in \mathbb{R}$  and for all  $x \in (0, \pi)$  such that  $\xi(t)(x) \neq 0$ .

The definition of non-autonomous equilibria was inspired by the scenarios of perturbations of structurally stable problems. If we make a sufficiently small and regular perturbation of a structurally stable autonomous problem, the structure will remain “the same”. In this case, it is easy to construct examples for which the non-autonomous equilibria develop an important role.

In the next Chapters, we will see two examples of non-autonomous problem (that are not necessarily perturbations) for which we can construct the non-autonomous equilibria.

### 2.3.4 Stability and of equilibria

We have seen that the equilibria develop an important role in describing the attractor of a gradient semigroup. Now, we will explore what local information can be obtained by studying neighborhoods of equilibria.

Denote by  $\{S(t, s) : (t, s) \in \mathcal{P}\}$  the evolution process associated to (2.3).

**Definition 2.3.22.** Suppose that  $\phi$  is an equilibrium of (2.3). We say that  $\phi$  is stable if, given  $\varepsilon > 0$ , we find  $\delta > 0$  for which  $\|u_0 - \phi\|_\alpha < \delta$  implies  $\|S(t, s)u_0 - \phi\|_\alpha < \varepsilon$  for  $t \geq s$ . Otherwise,  $\phi$  is called unstable.

We say that  $\phi$  is uniformly asymptotically stable if there is an  $\varepsilon > 0$  such that  $\|u_0 - \phi\|_\alpha < \varepsilon$  implies that,  $\|S(t, s)u_0 - \phi\|_\alpha \rightarrow 0$  as  $t - s \rightarrow +\infty$ .

We will summarize Theorems 5.1.1 and 5.1.3 from (HENRY, 1981) on the following result.

**Theorem 2.3.23.** Suppose that  $\phi$  is an equilibrium of (2.3) for which

$$f(t, \phi + h) = f(t, \phi) + Bh + g(t, h)$$

where  $B : X^\alpha \rightarrow X$  is a bounded operator and  $\|g(t, h)\| = o(\|h\|_\alpha)$  as  $\|h\|_\alpha \rightarrow 0$ <sup>1</sup>.

Then we have the following:

(Stability) If  $\sigma(-A - B) \subset \{z \in \mathbb{C} : \operatorname{Re} z > \beta\}$  for some  $\beta > 0$ , then  $\phi$  is uniformly asymptotically stable in  $X^\alpha$ .

(Instability) Additionally, suppose that  $g(t, 0) = 0$ ,  $g$  is locally Lipschitz in the second variable: that is, for each  $r > 0$  there is a  $C = C(r) > 0$  such that  $\|g(t, u) - g(t, v)\| \leq C\|u - v\|_\alpha$  for  $\|u\|_\alpha, \|v\|_\alpha < r$ .

If  $\sigma(-A - B) \cap \{z \in \mathbb{C} : \operatorname{Re} z < 0\} \neq \emptyset$  then  $\phi$  is unstable. To be more precise, there is  $\varepsilon_0 > 0$  and a sequence  $\{u_0^n\}_{n \in \mathbb{N}} \in X^\alpha$  converging to  $\phi$ , for which

$$\sup_{t \geq s} \|u(t, s, u_0^n) - \phi\|_\alpha \geq \varepsilon_0 > 0,$$

for all  $n \in \mathbb{N}$ .

This theorem says a semilinear problem behaves near an equilibrium similarly to a linear problem close to 0. Consequently, study the stability of  $\phi$  for (2.3) can be made by studying the stability of 0 for the approximation linear problem  $u_t = Au + f_x(t, \phi)u$ ,  $t > s$ .

### 2.3.5 Local information near an equilibrium of (2.3)

Now, we will explore the saddle-point property. An equilibrium has the saddle-point property if we can distinguish the directions that go from the equilibrium such as the ones that leave a neighborhood of that equilibrium as time evolves. The result we will present here can be found in (HENRY, 1981).

**Theorem 2.3.24** ((HENRY, 1981)). Consider  $x_0$  an equilibrium of (2.3). Assume

$$f(t, x_0 + h) = Ax_0 + Bh + g(t, h)$$

where

- (i)  $B : X^\alpha \rightarrow X$  is a bounded linear operator;
- (ii)  $g(t, 0) = 0$ ,  $\|g(t, h)\| = o(\|h\|_\alpha)$  as  $\|h\|_\alpha \rightarrow 0$ ;

<sup>1</sup>  $\|g(t, h)\|$  goes to zero faster than  $\|h\|_\alpha$  as  $\|h\|_\alpha \rightarrow 0$

(iii) For each  $r > 0$ , we find  $\rho(r) > 0$ , with  $\rho(r) \rightarrow 0$  as  $r \rightarrow 0$ , such that

$$\|g(t, z_1) - g(t, z_2)\| \leq \rho(r) \|z_1 - z_2\|_\alpha$$

for  $\|z_j\|_\alpha \leq r$ ,  $j = 1, 2$ ;

(iv) Denote  $L = A + B$  and assume that  $\sigma(L) \cap \{z \in \mathbb{C} : \operatorname{Re} z = 0\} = \emptyset$ . Then we can construct projections  $E_1, E_2$  in a way  $X = X_1 \oplus X_2$  where  $X_1$  corresponds to the spectral sets  $\sigma_1 = \sigma(L) \cap \{\lambda \in \mathbb{C} : \operatorname{Re} \lambda > 0\}$  and  $\sigma_2 = \sigma \cap \{\lambda \in \mathbb{C} : \operatorname{Re} \lambda < 0\}$ .

In these conditions, there are  $M \geq 1$  and  $\rho > 0$  for which we can define the local stable and unstable manifolds

$$W_{loc}^s(x_0) = \{u_0 : \|E_2 u_0\|_\alpha \leq \frac{\rho}{2M} \text{ and } \|u(t; t_0, u_0)\|_\alpha \leq \rho, \text{ for } t \geq t_0\}$$

and

$$W_{loc}^u(x_0) = \{u_0 : \|E_1 u_0\|_\alpha \leq \frac{\rho}{2M} \text{ for which there is a solution } u : \mathbb{R} \rightarrow X \text{ satisfying} \\ \|u(t; t_0, u_0)\|_\alpha \leq \rho, \text{ for } t \leq t_0\}.$$

**Remark 2.3.25.** We have taken the operator  $L$  as the opposite operator to the one in Theorem 5.2.1 in (HENRY, 1981).

### 2.3.6 Hyperbolic solutions

Consider  $X$  a Banach space. Denote the space of bounded linear operators from  $X$  to itself by  $L(X)$ .

**Definition 2.3.26.** We say that a linear evolution process  $\{L(t, s) : t \geq s\} \subset L(X)$  has exponential dichotomy if there are  $M \geq 1$ ,  $\beta > 0$  and a family of projections  $\{Q(t) : t \in \mathbb{R}\}$  such that

- (i)  $L(t, s)Q(s) = Q(t)L(t, s)$ , for all  $t \geq s$ ,
- (ii) For  $t \geq s$ ,  $L(t, s)|_{R(Q(s))} : R(Q(s)) \rightarrow R(Q(t))$  is an isomorphism (and its inverse will be denoted by  $L(s, t) : R(Q(t)) \rightarrow R(Q(s))$ ).

(iii) The following inequalities hold

$$\|L(t, s)(I - Q(s))\|_{L(X)} \leq M e^{-\beta(t-s)}, \text{ for all } t \geq s \\ \|L(t, s)Q(s)\|_{L(X)} \leq M e^{\beta(t-s)}, \text{ for all } t < s.$$

Exponential dichotomy is a very interesting subject. To see more details about this topic, we recommend reading (HENRY, 1981; CARVALHO; LANGA; ROBINSON, 2013; COPPEL, 1978). An important aspect about the exponential dichotomy is its robustness under perturbation:

**Theorem 2.3.27.** Suppose that  $\{L(t, s) : (t, s) \in \mathcal{P}\}$  is a linear evolution process that admits exponential dichotomy, with projections  $\{Q(t) : t \in \mathbb{R}\}$  and constants  $M \geq 1$  and  $\beta > 0$ . Additionally, assume that

$$\sup_{0 \leq t-s \leq 1} \|L(t, s)\|_{L(X)} < +\infty.$$

Then, for each pair  $\tilde{M} > M$  and  $\tilde{\beta} < \beta$ , we find  $\varepsilon > 0$  for which any given linear evolution process  $\{S(t, s) : (t, s) \in \mathcal{P}\}$ , satisfying

$$\sup_{0 \leq t-s \leq 1} \|S(t, s) - L(t, s)\|_{L(X)} \leq \varepsilon,$$

has exponential dichotomy with constant  $\tilde{M}$  and exponent  $\tilde{\beta}$  and a family of projections  $\{\tilde{Q}(t) : t \in \mathbb{R}\}$  with

$$\sup_{t \in \mathbb{R}} \|\tilde{Q}(t) - Q(t)\|_{L(X)} \leq \frac{2\tilde{M}^2}{1 - e^{-\tilde{\beta}}} \varepsilon.$$

Now, we will present the concept of hyperbolicity of a solution  $\xi : \mathbb{R} \rightarrow X$  of (2.3).

**Definition 2.3.28.** Assume that  $f : \mathbb{R} \times X \rightarrow X$  is continuously differentiable. We say that  $\xi : \mathbb{R} \rightarrow X$  is a hyperbolic solution of (2.3) if it is a solution of (2.3) and the linear process  $\{L(t, s) : (t, s) \in \mathcal{P}\}$  given by

$$L_\xi(t, s) = e^{A(t-s)} + \int_s^t e^{A(t-r)} D_x f(r, \xi(r)) L_\xi(r, s) dr \quad (2.6)$$

has an exponential dichotomy. Here  $D_x f(r, \xi(r))$  represents the Fréchet derivative of  $f$  at the point  $(r, \xi(r))$ .

The hyperbolic solutions are very interesting, because they locally characterize the behavior of the process near them. We can show that they are also robust under perturbation.

**Theorem 2.3.29.** Consider  $\xi : \mathbb{R} \rightarrow X$  a global solution of (2.3). We will assume the following:

1. The solution  $\xi$  is bounded in  $X$ , that is, we find  $B > 0$  such that  $\|\xi(t)\|_X \leq B$ , for all  $t \in \mathbb{R}$ .
2. The solution  $\xi$  is hyperbolic, that is, the process  $\{L(t, s) : (t, s) \in \mathcal{P}\}$  defined in (2.6) has exponential dichotomy with constant  $M \geq 1$  and exponent  $\beta > 0$ .
3. It is also valid that

$$\sup_{t \in \mathbb{R}} \sup_{\|u\|_X \leq B+1} \|f(t, u)\|_X + \|D_x f(t, u)\|_{L(X)} < +\infty$$

and, for each  $\varepsilon > 0$ ,

$$\sup_{t \in \mathbb{R}} \sup_{\|u\|_X \leq \varepsilon} \|f(t, \xi(t) + h) - f(t, \xi(t)) - D_x(t, \xi(t))h\|_{X^1} < \frac{\beta \varepsilon}{4M}.$$

In these conditions, if  $g : \mathbb{R} \times X \rightarrow X$  is a continuously differentiable function satisfying

$$\sup_{t \in \mathbb{R}} \sup_{\|u\|_X \leq B+1} \|f(t, u) - g(t, u)\|_X + \|D_x f(t, u) - D_x g(t, u)\|_{L(X)} < \frac{\beta \varepsilon}{4M},$$

then the process  $\{S_g(t, s) : (t, s) \in \mathcal{D}\}$ , given by

$$S_g(t, s) = e^{A(t-s)} + \int_s^t e^{A(t-r)} g(r, S(r, s)) dr,$$

admits a unique hyperbolic global solution  $\eta : \mathbb{R} \rightarrow X$  and

$$\sup_{t \in \mathbb{R}} \|\xi(t) - \eta(t)\|_X < \varepsilon.$$

The above theorem says that hyperbolic solutions are robust under perturbation, that is, it is a property that is preserved for close problems.

Now, we will explore the properties associated with the unstable and stable sets of a hyperbolic global solution  $\xi$  of (2.3). Recall the definitions of the unstable and stable sets of  $\xi$ :

$$W^u(\xi)(t) = \{x \in X : \text{there is a solution } \eta : \mathbb{R} \rightarrow X \text{ of (2.3) with } \eta(t) = x \text{ and } \lim_{s \rightarrow -\infty} \|\eta(s) - \xi(s)\|_X = 0\}$$

and

$$W^s(\xi)(t) = \left\{ x \in X : \lim_{r \rightarrow +\infty} \|S(r, t)x - \xi(r)\|_X = 0 \right\}.$$

It can be shown that  $W_{loc}^u(\xi)(\cdot)$  and  $W_{loc}^s(\xi)(\cdot)$  can be written as graphs of a Lipschitz map. Here, we will give a sketch of the proof and, for more details, we recommend consulting on Chapter 8 of (CARVALHO; LANGA; ROBINSON, 2013).

In order to do that, we make a translation. Suppose that  $u$  is a global bounded solution of (2.3) close to  $\xi$ . Then, we may write  $u(t) = \xi(t) + x(t)$ ,  $t \in \mathbb{R}$ , and we can show that  $u(\cdot)$  satisfies

$$u(t) = L_\xi(t, s)u(s) + \int_s^t L_\xi(t, r)[f(r, u(r)) - D_x f(r, \xi(r))u(r)] dr.$$

Now, using the notation of Definition 2.3.28, there exist a constant  $M \geq 1$  and  $\beta > 0$  and a family of projection  $\{P(t) : t \in \mathbb{R}\}$  such that

$$\begin{aligned} \|L_\xi(t, s)(I - P(s))\|_{L(X)} &\leq M e^{-\beta(t-s)}, \quad t \geq s, \\ \|L_\xi(t, s)P(s)\|_{L(X)} &\leq M e^{\beta(t-s)}, \quad t < s. \end{aligned}$$

First, it is shown the existence of the unstable sets as a graph. To show that, we consider for  $t \in \mathbb{R}^+$  and  $x \in X$ ,

$$F(t, x) = f(t, x + \xi(t)) - f(t, \xi(t)) - D_x f(t, \xi(t))x.$$

Since  $F(t, 0) = 0$  and  $D_x F(t, 0) = 0$ , for all  $t \in \mathbb{R}$ . Now, since  $F$  is continuously differentiable on the second variable (uniformly on  $t$ ), then for each  $\varepsilon > 0$ , there is a  $\rho = \rho(\varepsilon) > 0$  such that for  $x, y \in X$  with  $\|x\|, \|y\| \leq \varepsilon$ ,

$$\sup_{t \in \mathbb{R}} \|F(t, x)\| \leq \rho \text{ and } \sup_{t \in \mathbb{R}} \|F(t, x) - F(t, y)\| \leq \rho \|x - y\|. \quad (2.7)$$

We can consider the following global Lipschitz extension  $G : \mathbb{R} \times X \rightarrow X$ , with

$$G(t, x) = \begin{cases} F(t, x), & \text{if } \|x\| \leq \varepsilon \\ F(t, \frac{\varepsilon x}{\|x\|}), & \text{if } \|x\| > \varepsilon. \end{cases}$$

This extension allows us to study the unstable and stable sets of graphs when we consider  $G$ . Therefore, the result is valid for  $W_{loc}^u(0)$  and  $W_{loc}^s(0)$ . Recall that we are consider the translation to 0.

Consequently,  $x(\cdot) = u(\cdot) - \xi(\cdot)$  satisfies

$$x(t) = L_\xi(t, s)x(s) + \int_s^t L_\xi(t, r)[f(r, \xi(r) + x(r)) - f(r, \xi(r)) - D_x f(r, \xi(r))x(r)]dr. \quad (2.8)$$

For  $t \in \mathbb{R}$ , denote  $p(t) = P(t)x(t)$ ,  $Q(t) = I - P(t)$  and  $q(t) = Q(t)x(t)$ . From the equation above, we obtain the following system

$$\begin{aligned} p(t) &= L_\xi(t, s)p(s) + \int_s^t L_\xi(t, r)P(r)F(r, p(r) + q(r))dr \\ q(t) &= L_\xi(t, s)q(s) + \int_s^t L_\xi(t, r)Q(r)F(r, p(r) + q(r))dr \end{aligned} \quad (2.9)$$

Now,  $q$  is given in (2.9) and we can use the exponential dichotomy and the uniform boundedness of the integral to rewrite  $q$  as

$$q(t) = \int_{-\infty}^t L_\xi(t, r)Q(r)F(r, p(r) + q(r))dr, \quad t \in \mathbb{R}.$$

We want to prove that there is a  $\Sigma^u : \mathbb{R} \times P(t)X \rightarrow Q(t)X$  such that

$$W^u(0)(t) = \{p + \Sigma^u(t, p) : p \in P(t)X\}.$$

For  $D, L > 0$ , define the metric space

$$\begin{aligned} Lip^u(D, L) = \{ \Sigma : \mathbb{R} \times X \rightarrow X : \Sigma(t, \cdot) : P(t)X \rightarrow Q(t)X, \sup_{x \in X} \sup_{t \in \mathbb{R}} \|\Sigma(t, P(t)x)\|_X \leq D \text{ and} \\ \|\Sigma(t, P(t)x) - \Sigma(t, P(t)y)\|_X \leq L\|P(t)x - P(t)y\|_X \}. \end{aligned}$$

It can be shown that  $Lip^u(D, L)$  is a complete metric space.

Define the contraction map  $\mathcal{T} : Lip^u(D, L) \rightarrow Lip^u(D, L)$  given by

$$\mathcal{T}(\Sigma)(t, \zeta) = \int_{-\infty}^t L_\xi(t, r)Q(r)F(r, p(r) + \Sigma(r, p(r)))dr, \quad t \in \mathbb{R}.$$

Now, using the exponential dichotomy of  $\{L_\xi(t, s) : t \geq s\}$  and the limitations on  $F$ , we are able to choose  $\rho > 0$  in (2.7) sufficiently small such that  $\mathcal{T}$  defines a contraction. The result is summarized in the following.

**Theorem 2.3.30.** (CARVALHO; LANGA; ROBINSON, 2013, Theorem 8.4) Consider the  $\{L(t, s) : (t, s) \in \mathcal{C}\}$  defined as in (2.6). We assume that this process has an exponential dichotomy with constant  $M \geq 1$  and exponent  $\beta > 0$  for a family of projections  $\{P(t) : t \in \mathbb{R}\}$ . Denote  $Q(t) = (I - P(t))$ ,  $t \in \mathbb{R}$ . Fix  $D > 0$ ,  $L > 0$  and  $\nu \in (0, 1)$  and consider  $\rho > 0$  in (2.7) such that

$$\frac{\rho M}{\beta} \leq D, \quad \frac{\rho M(1+L)}{\beta} \leq \nu < 1, \quad \frac{\rho M^3(1+L)}{\beta - \rho M(1+L)} \leq L, \quad \frac{2\beta\rho M + \rho^2 M^3(1+L)}{2\beta - \rho M(1+L)} < (1-\nu)\beta.$$

Then, there exists a map  $\Sigma \in Lip^u(D, L)$  such that the unstable manifold  $W^u(0)$  of (2.8) is given by

$$W^u(0)(t) = \{p + \Sigma^u(t, p) : p \in P(t)X\}, \quad t \in \mathbb{R}.$$

Now, if  $x(\cdot)$  is a solution of (2.8), for  $t \geq t_0$ , then  $x(t) = p(t) + q(t)$  where  $p(t)$  and  $q(t)$  is given in (2.9). In this conditions, there are constants  $N \geq 1$  and  $\gamma > 0$  such that

$$\|q(t) - \Sigma^u(t, p(t))\|_X \leq N e^{-\gamma(t-t_0)} \|q(t_0) - \Sigma^u(t_0, p(t_0))\|_X, \quad t \geq t_0.$$

Now, if  $x(\cdot)$  is defined for all  $t \in \mathbb{R}$ , then

$$\|p(t)\|_X \leq N e^{[\beta - \rho M(1+L)](t-\tau)} \|p(\tau)\|_X, \quad \text{for } t \leq \tau.$$

In fact, we can also describe  $W^s(0)$  as graph. Using the previous notation, for  $D, L > 0$ , we define

$$Lip^s(D, L) = \{\Sigma : \mathbb{R} \times X \rightarrow X : \Sigma(t, \cdot) : Q(t) \rightarrow P(t), \text{ with } \sup_{t \in \mathbb{R}} \sup_{x \in X} \|\Sigma(t, Q(t)x)\|_X \leq D \text{ and}$$

$$\|\Sigma(t, Q(t)x) - \Sigma(t, Q(t)y)\|_X \leq L \|Q(t)x - Q(t)y\|_X, \quad x, y \in X\}$$

and the map

$$\mathcal{T}^s : Lip^s(D, L) \rightarrow Lip^s(D, L)$$

given by

$$\mathcal{T}^s(\Sigma)(t, \zeta) = - \int_t^{+\infty} L_\xi(t, r) Q(r) F(r, q(r) + \Sigma(r, q(r))) dr, \quad t \in \mathbb{R}.$$

**Theorem 2.3.31.** (CARVALHO; LANGA; ROBINSON, 2013, Theorem 8.5) Under the same assumptions of Theorem 2.3.30, there is a  $\Sigma^s \in Lip^s(D, L)$  (which is the fixed point of  $\mathcal{T}^s$ ) such that the stable manifold  $W^s(0)$  of (2.8) is given by

$$W^s(0) = \{q + \Sigma^s(t, q) : q \in Q(t)X, t \in \mathbb{R}\}.$$

Consider  $x(\cdot)$  is a global solution of (2.8),  $x(t) = p(t) + q(t)$ ,  $t \in \mathbb{R}$ , then there exist  $N \geq 1$  and  $\gamma > 0$  such that

$$\|p(t) - \Sigma^s(t, q(t))\|_X \leq N e^{\gamma(t-t_0)} \|p(t_0) - \Sigma^s(t_0, q(t_0))\|_X, \quad \text{for } t, t_0 \in \mathbb{R}, t \leq t_0$$

and

$$\|q(t)\|_X \leq N\|q(\tau)\|_X e^{-(\beta - \rho M(1+L))(t-\tau)}, \quad t \geq \tau.$$

The above inequality is also true if  $x(\cdot)$  is only defined on  $[\tau, +\infty)$ .





## THE CHAFEE-INFANTE PROBLEM AND ITS NON-AUTONOMOUS VARIATION

In this chapter, we will give a general overview on the Chafee-Infante problem, which will be useful for us throughout the next chapters.

Denote by  $C^k(\mathbb{R})$  the set of continuous functions  $f : \mathbb{R} \rightarrow \mathbb{R}$  which admits  $k$  derivatives which are continuous, for  $k \in \mathbb{N}$ .

The Chafee-Infante problem, which appeared in the literature for the first time in 1974 (see (CHAFEE; INFANTE, 1974) and (CHAFEE; INFANTE, 1974/75)), can be represented by the following initial boundary value problem,

$$\begin{cases} u_t - u_{xx} = \lambda f(u), & x \in (0, \pi), t > 0, \\ u(0, t) = u(\pi, t) = 0, & t \geq 0, \\ u(\cdot, s) = u_0(\cdot) \in H_0^1(0, \pi). \end{cases} \quad (3.1)$$

where  $\lambda > 0$  is a parameter and  $f \in C^2(\mathbb{R})$  satisfies  $f(0) = 0$ ,  $f'(0) = 1$  and

$$sf''(s) < 0, \text{ for } s \neq 0, \text{ and } \limsup_{|s| \rightarrow +\infty} \frac{f(s)}{s} < 0. \quad (3.2)$$

This is the infinite dimensional model for which the asymptotics is the most well-understood. We know that it is gradient, has a finite number of equilibria and, along a connection between two equilibria, the stable and unstable manifolds intersect transversely (see (HENRY, 1985; ANGENENT, 1986)). Moreover, we also know precisely the diagram of connections between equilibria (see (FIEDLER; ROCHA, 1996)) and that this diagram is stable under autonomous and non-autonomous perturbations (see (HENRY, 1985; ANGENENT, 1986; BORTOLAN *et al.*, 2021; BORTOLAN; CARVALHO; LANGA, 2020)).

Let  $C(H_0^1(0, \pi))$  be the space of continuous functions from  $H_0^1(0, \pi)$  to itself. It is well known that the problem (3.1) is globally well-posed. Denote by  $\{T(t) : t \geq 0\}$  its solution

operator, that is, if  $\mathbb{R}^+ \ni t \mapsto u(t, u_0) \in H_0^1(0, \pi)$  is the global solution of (3.1), we write  $T(t)u_0 = u(t, u_0)$ . The family  $\{T(t) : t \geq 0\} \subset C(H_0^1(0, \pi))$  is a gradient semigroup with Liapunov function  $V : H_0^1 \rightarrow \mathbb{R}$  given by

$$V(u) = \frac{1}{2} \int_0^\pi u_x^2(x) dx - \frac{1}{2} \int_0^\pi \int_0^{u(x)} f(s) ds dx.$$

for all  $u \in H_0^1(0, \pi)$ , that is,

- i)  $V$  is continuous;
- ii)  $[0, \infty) \ni t \mapsto V(T(t)u) \in \mathbb{R}$  is non-increasing;
- iii)  $V(T(t)u) = V(u)$  for all  $t \geq 0$  implies that  $u$  is an equilibrium of (3.1).

Also, this semigroup has a global attractor  $\mathcal{A}$  which, due to the gradient structure, is given by  $\mathcal{A} = W^u(\mathcal{E})$ , where  $\mathcal{E}$  is the set of equilibria and  $W^u(\mathcal{E})$  its unstable set.

In what follows, we will present some of the results in the literature about this well-known problem. We are interested in the finer structure of its global attractor. We will present the bifurcation of equilibria and the structure of the attractor. In the last section, we will also offer a topological criteria to identify problems whose global attractor is semi-conjugated to the global attractor of (3.1).

### 3.1 The bifurcation of the Chafee-Infante problem

In this section, we are interested in investigating the equilibria of (3.1), that is, solutions that are not time-dependent. In other words, we search for solutions of

$$\begin{cases} u_{xx} + \lambda f(u) = 0, & x \in (0, \pi), \\ u(0) = u(\pi) = 0. \end{cases}$$

The interest in no time-dependent solutions come from their role in describing the dynamics of gradient systems. Here, we will present the analysis made by Chafee and Infante in order to construct the sequence of bifurcation of equilibria from 0.

For  $\lambda \in (j^2, \infty)$ , let  $\phi_{j,\lambda}^\pm$  be the solutions of (3.1) with  $j+1$  zeros in the interval  $[0, \pi]$  and  $\kappa(\phi_{j,\lambda}^\kappa)'(0) > 0$ ,  $\kappa \in \{+, -\}$ , they are solutions of the initial value problem

$$\begin{cases} u_{xx} + \lambda f(u) = 0, & x > 0 \\ u(0) = 0, & u'(0) = v_0 \end{cases} \quad (3.3)$$

where  $v_0 \neq 0$  is suitably chosen in such a way that  $u(\pi) = 0$ . By (3.2), there are  $a^- < 0 < a^+$  such that  $f(a^\pm) = 0$  and  $f(s)s > 0$  for  $s \in (a^-, a^+) \setminus \{0\}$ . Now, denote by  $F(s) = \int_0^s f(r)dr$ .

For a given  $v_0$  let  $E = \frac{v_0^2}{2} \in [0, \min\{F(a_+), F(a_-)\}]$ , and note that a solution of (3.3) must satisfy

$$\frac{u'(x)^2}{2} + \lambda F(u) = \lambda E.$$

Let  $U^+(E) > 0$  and  $U^-(E) < 0$  be defined by  $F(U^\pm(E)) = E$ . Then, if

$$\tau_\lambda^\kappa(E) = \kappa \left( \frac{2}{\lambda} \right)^{\frac{1}{2}} \int_0^{U^\kappa(E)} (E - F(u))^{-\frac{1}{2}} du, \quad \kappa \in \{+, -\}, \quad (3.4)$$

define, for  $j$  odd,

$$\mathcal{T}_\lambda^+(E) = \frac{j+1}{2} \tau_\lambda^+(E) + \frac{j-1}{2} \tau_\lambda^-(E), \quad \mathcal{T}_\lambda^-(E) = \frac{j+1}{2} \tau_\lambda^-(E) + \frac{j-1}{2} \tau_\lambda^+(E)$$

or, for  $j$  even,

$$\mathcal{T}_\lambda^\pm(E) = \frac{j}{2} \tau_\lambda^+(E) + \frac{j}{2} \tau_\lambda^-(E).$$

The choices of  $E$  that gives us the solutions  $\phi_{j,\lambda}^\pm$  are  $\mathcal{T}_\lambda^\pm(E_{j,\lambda}^\pm) = \pi$ . It can be shown that:

- For  $\kappa \in \{+, -\}$ , the map  $(0, F(a_\kappa)) \ni E \rightarrow \tau_\lambda^\kappa(E)$  is strictly increasing;
- For  $\kappa \in \{+, -\}$ , as  $E \rightarrow F(a_\kappa)$ ,  $\tau_\lambda^\kappa \rightarrow +\infty$ ;
- as  $E \rightarrow 0$ ,  $\tau_\lambda^\pm \rightarrow \frac{\pi}{2\sqrt{\lambda}}$ .

As a consequence, we have the following result:

**Theorem 3.1.1.** (CHAFEE; INFANTE, 1974) If  $N^2 < \lambda \leq (N+1)^2$ , for some  $0 < N \in \mathbb{N}$ , then (3.1) has  $2N+1$  equilibria  $\phi_j^+, \phi_j^-, 0 \leq j \leq N$ , where:

- (i)  $\phi_0^+ = \phi_0^- = 0$ ;
- (ii)  $\phi_j^+$  and  $\phi_j^-$  have  $j+1$  zeros in  $[0, \pi]$ ,  $1 \leq j \leq N$ ;
- (iii)  $(\phi_j^+)'(0) > 0$  and  $(\phi_j^-)'(0) < 0$ .
- (iv) There is no other equilibrium of (3.1).

All equilibria of the Chafee-Infante problem appear as 0 passes by a supercritical pitchfork bifurcation.

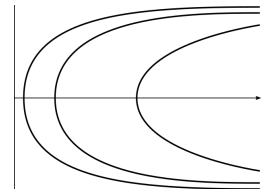

**Remark 3.1.2.** In the case that  $f$  is an odd function, the equilibrium  $\phi_j^+$  vanishes exactly at  $\{k\frac{\pi}{j} : 0 \leq k \leq j\}$ ,  $1 \leq j \leq N$ ;  $\phi_j^- = -\phi_j^+$ ,  $\phi_j^+(x) > 0$  for  $x \in (0, \frac{\pi}{j})$ ,  $1 \leq j \leq N$ ;  $\phi_j(x) = \phi_j(\frac{\pi}{j} - x)$ ,  $x \in (0, \frac{\pi}{j})$  and  $\phi_j(x) = -\phi_j(x - \frac{\pi}{j})$ ,  $x > \frac{\pi}{j}$ ,  $1 \leq j \leq N$ .

The following result synthesizes the spectral properties of the linearized operator

**Lemma 3.1.3.** The spectrum of the operator

$$\begin{cases} L_0^\phi : D(L_0^\phi) \subset L^2(0, \pi) \rightarrow L^2(0, \pi), \\ D(L_0^\phi) = H^2(0, \pi) \cap H_0^1(0, \pi), \\ L_0^\phi v = v'' + \lambda f'(\phi)v, v \in D(L_0^\phi). \end{cases} \quad (3.5)$$

satisfies

- i) If  $\phi(x) \neq 0$  in  $(0, \pi)$ , then  $L_0^\phi$  has only negative eigenvalues.
- ii) If  $\phi(x) = 0$ , for some  $x \in (0, \pi)$ , then  $L_0^\phi$  has at least one positive eigenvalue.
- iii) 0 is always in the resolvent of  $L_0^\phi$ .

*Proof.* Parts i) e ii) were proved by (CHAFEE; INFANTE, 1974/75) and can also be found in (HENRY, 1981, Section 5.3). We will give an idea of the proof of iii), which is a consequence of the results in (SMOLLER, 1994, Section F of Chapter 24).

We prove only the hyperbolicity of  $\phi_{j,\lambda}^+$ , the other case is similar. We consider the family  $u(\cdot, E)$  of solutions of the problem

$$\begin{cases} u''(x) + \lambda f(u(x)) = 0, \\ u(0, E) = 0, u'(0, E) = \sqrt{2\lambda E} \text{ and } u(\tau_\lambda^+(E)) = 0. \end{cases} \quad (3.6)$$

Consequently,  $\eta = (\phi_{j,\lambda}^+)_x$  and  $\psi = \frac{\partial u}{\partial E}(x, E)|_{E=E_j^+(\lambda)}$  are solutions of

$$v''(x) + \lambda f'(\phi_{j,\lambda}^+)v(x) = 0 \quad (3.7)$$

with  $\eta(0) \neq 0$ ,  $\eta'(0) = 0$  and  $\psi(0) = 0$ ,  $\psi'(0) = \frac{\sqrt{\lambda}}{\sqrt{2E_j^+(\lambda)}} \neq 0$ . This proves that  $\eta$  and  $\psi$  are linearly independent and any solution (3.7) must be of the form

$$\omega = c_1 \eta + c_2 \psi.$$

Let us show that if  $\omega(0) = \omega(\mathcal{T}_\lambda^+(E_j^+(\lambda))) = 0$  then, necessarily,  $\omega \equiv 0$ . In fact,  $\psi(0) = 0$ ,  $\eta(0) \neq 0$  and  $c_1 \eta(0) + c_2 \psi(0) = 0$  implies  $c_1 = 0$ . Now, since  $u(\mathcal{T}_\lambda^+(E), E) = 0$  for all  $E$ , we have that  $0 = \frac{\partial u}{\partial x}(\mathcal{T}_\lambda^+(E), E)(\mathcal{T}_\lambda^+(E))'(E) + \frac{\partial u}{\partial E}(\mathcal{T}_\lambda^+(E), E)$ . It is clear that  $\frac{\partial u}{\partial x}(\mathcal{T}_\lambda^+(E), E) \neq 0$  and since  $(\mathcal{T}_\lambda^+(E))'(E) \neq 0$  (see (CHAFEE; INFANTE, 1974/75)), we have  $\psi(\mathcal{T}_\lambda^+(E_j^+(\lambda))) = \frac{\partial u}{\partial E}(\mathcal{T}_\lambda^+(E_j^+(\lambda)), E_j^+(\lambda)) \neq 0$ . Hence, we also have that  $c_2 = 0$  and the only solution  $\omega$  of (3.7) which satisfies  $\omega(0) = \omega(\pi) = 0$  is  $\omega \equiv 0$ . This proves that 0 is not in the spectrum of the linearization around  $\phi$ . □

**Theorem 3.1.4.** Under the same notation used in Theorem 3.1.1, we have the following:

**Stability** If  $\lambda \in (0, 1]$ , then 0 is the only equilibrium of (3.1) and it is stable. If  $\lambda > 1$ , then  $\phi_1^+$  and  $\phi_1^-$  are stable and the other equilibria are unstable.

**Hyperbolicity** All equilibria of (3.1) are hyperbolic, with the exception of the equilibrium 0 for values  $\lambda = a(0)N^2$ ,  $N \in \mathbb{N}$ .

*Proof.* Suppose that  $\phi$  is an equilibrium of (3.1). Since  $f \in C^2(\mathbb{R})$ , we have for  $h \in H^2(0, \pi) \cap H_0^1(0, \pi)$ ,

$$f(\phi + h) = \frac{-\phi_{xx}}{\lambda} + B^\phi h + g(h)$$

where  $B^\phi h = f'(\phi)h$ ,  $g^\phi(h) = f(\phi + h) - f(\phi) - f'(\phi)h$ .

We can see that

- (i)  $B^\phi : X^\alpha \rightarrow X$  is a bounded linear operator;
- (ii)  $g(0) = 0$ ,  $\|g(h)\| = o(\|h\|_\alpha)$  as  $\|h\|_\alpha \rightarrow 0$ , since  $f \in C^2(\mathbb{R})$ .

Now, for  $r > 0$ , consider  $h_1, h_2 \in B_{H_0^1(0, \pi)}(0, r)$ . We have

$$\begin{aligned} \|g(h_1) - g(h_2)\| &= \|f(\phi + h_1) - f(\phi + h_2) + f'(\phi)(h_1 - h_2)\| \\ &= \|f'(\phi + \theta_1 h_1 + (1 - \theta_1)h_2)(h_1 - h_2) - f'(\phi)(h_1 - h_2)\| \\ &\leq \|f'(\phi + \theta_1 h_1 + (1 - \theta_1)h_2) - f'(\phi)\| \|h_1 - h_2\| \\ &\leq \|f''(\phi + \theta_2[\theta_1 h_1 + (1 - \theta_1)h_2])(\theta_1 h_1 + (1 - \theta_1)h_2)\| \|h_1 - h_2\|_{H_0^1(0, \pi)}, \end{aligned}$$

where the existence of functions  $\theta_1, \theta_2 : [0, \pi] \rightarrow [0, 1]$  is assured by the regularity of  $f$ . Now, since  $f \in C^2(\mathbb{R})$ , there is a  $M > 0$  for which

$$\|f''(\phi + \theta_2[\theta_1 h_1 + (1 - \theta_1)h_2])\| \|\theta_1 h_1 + (1 - \theta_1)h_2\| \leq M \left( \|h_1\|_{H_0^1(0, \pi)} + \|h_2\|_{H_0^1(0, \pi)} \right) \leq 2Mr.$$

Now, take  $\rho(r) = 2Mr$ . We have that

$$\|g(h_1) - g(h_2)\| \leq \rho(r) \|h_1 - h_2\|_{H_0^1(0, \pi)}$$

and  $\rho(r) \rightarrow 0$  as  $r \rightarrow 0$ .

Now, we can apply Theorems 2.3.23 and 2.3.24 and Lemma 3.1.3 and the result follows.  $\square$

For  $\lambda > j^2$ ,  $j \in \mathbb{N}$ ,  $\kappa \in \{+, -\}$ , denote by  $\phi_{j, \lambda}^\kappa$  the equilibrium of (3.1) that has  $j + 1$  zeros in  $[0, \pi]$  and  $\kappa(\phi_{j, \lambda}^\kappa)'(0) > 0$ .

**Theorem 3.1.5.** For each positive integer  $j$ , and  $\kappa \in \{+, -\}$ , the function  $(j^2, \infty) \ni \lambda \mapsto \phi_{j, \lambda}^\kappa \in H_0^1(0, \pi)$  is continuously differentiable and consequently the function  $(j^2, \infty) \ni \lambda \mapsto \|(\phi_{j, \lambda}^\kappa)_x\|^2 \in (0, \infty)$  is strictly increasing, continuously differentiable and  $\|(\phi_{j, \lambda}^\kappa)_x\|^2 \xrightarrow{\lambda \rightarrow \infty} \infty$ .

*Proof.* To show that  $(j^2, \infty) \ni \lambda \mapsto \phi_{j,\lambda}^\kappa \in H_0^1(0, \pi)$  is continuously differentiable at a point  $\lambda_0$  we recall that, for each  $\lambda \in (j^2, \infty)$  we already know that  $\phi_{j,\lambda}^\kappa$  is hyperbolic. Hence, to obtain the differentiability at  $\lambda = \lambda_0 \in (j^2, \infty)$  we recall that, for  $\lambda$  near  $\lambda_0$ ,  $\phi_{j,\lambda}^\kappa$  is the only fixed point of the map

$$T_{j,\lambda}^\kappa v := -\phi_{j,\lambda_0}^\kappa - (L_j^{\lambda_0, \kappa})^{-1} \left( \lambda f(v + \phi_{j,\lambda_0}^\kappa) - \lambda_0 f'(\phi_{j,\lambda_0}^\kappa)v - \lambda_0 f'(\phi_{j,\lambda_0}^\kappa)\phi_{j,\lambda_0}^\kappa \right)$$

in a small neighborhood of zero in  $H_0^1(0, \pi)$ . Now, since  $(j^2, \infty) \ni \lambda \mapsto T_{j,\lambda}^\kappa \in \mathcal{C}(H_0^1(0, \pi))$  is continuously differentiable we have that  $(j^2, \infty) \ni \lambda \mapsto \phi_{j,\lambda}^\kappa \in H_0^1(0, \pi)$  is continuously differentiable and the result follows.

The map  $(j^2, \infty) \ni \lambda \mapsto \|(\phi_{j,\lambda}^\kappa)_x\|^2 \in (0, \infty)$  is strictly increasing and  $\|(\phi_{j,\lambda}^\kappa)_x\|^2 \xrightarrow{\lambda \rightarrow \infty} \infty$ . Both results follow from (CABALLERO *et al.*, 2021, Lemma 5) and from the analysis done next.

It has been shown in (CHAFEE; INFANTE, 1974/75) that the time maps  $\tau_\lambda^\pm(\cdot)$ , defined in (3.4), are strictly increasing functions. Also, for a fixed  $E$ , clearly  $\lambda \mapsto \tau_\lambda^\pm(E)$  is strictly decreasing. Hence, since  $\mathcal{I}_\lambda^+(E_j^+(\lambda)) = \pi$ , from (3.4), must have that  $\kappa U^\kappa(E_j^\kappa(\lambda))$ ,  $\kappa \in \{+, -\}$ , is strictly increasing.

It follows that

$$g(\lambda) := \int_0^{\tau_\lambda^+(E_j^+(\lambda))} ((\phi_{j,\lambda}^\pm)_x)^2 dx = \sqrt{2\lambda} \int_0^{U^+(E_j^+(\lambda))} \sqrt{E_j^\pm(\lambda) - F(v)} dv$$

and

$$\int_0^{U^+(E_j^+(\lambda))} \sqrt{E_j^\pm(\lambda) - F(v)} dv$$

are strictly increasing functions of  $\lambda$ . Consequently,  $g(\lambda) \xrightarrow{\lambda \rightarrow \infty} \infty$  and we must have that  $\|(\phi_{j,\lambda}^\kappa)_x\|^2 \xrightarrow{\lambda \rightarrow \infty} \infty$ , completing the proof.  $\square$

**Remark 3.1.6.** The same reasoning can be used to show that  $(j^2, \infty) \ni \lambda \mapsto \phi_{j,\lambda}^\kappa \in H_0^1(0, \pi)$  is twice continuously differentiable,  $\kappa \in \{+, -\}$ .

## 3.2 Structure of the attractor and Morse Smale semigroup

Now, we will present an interesting effect that occurs for some linear one-dimensional problems. Basically, we will see that for some problems, the number of zeros (“lap-number”) of the solution decreases a.e. as time evolves. This study was presented by Matano (see (MATANO, 1982)) and it will be very useful in the next chapters. Here, we will present a version from (HENRY, 1981, Theorem 6).

**Lemma 3.2.1.** Consider the following problem

$$\begin{cases} v_t = p(t, x)v_{xx} + q(t, x)v_x + r(t, x)v, & x \in (0, \pi), t > 0, \\ v(t, 0) = v(t, \pi) = 0, & t \geq 0, \end{cases} \quad (3.8)$$

where we assume that

- (i) there is an interval  $[0, t_0]$ , for which the functions  $p, q$  and  $r$  are well-defined in  $[0, t_0] \times [0, \pi]$ . Also  $p > 0$  in this domain.
- (ii) there exist a continuous function  $v$  solution of (3.8), where  $v_x$  is continuous on  $(0, t_0] \times [0, \pi]$ ,  $v_t$  and  $v_{xx}$  are continuous on  $(0, t_0] \times (0, \pi)$ .

In these conditions, we can show that the number of components of

$$\{x : 0 < x < \pi \text{ and } v(t, x) \neq 0\}$$

decreases with time on  $0 \leq t \leq t_0$ .

**Remark 3.2.2.** The Lemma above is a particular case of (HENRY, 1985, Theorem 6).

Although the lemma above does not seem to be related to our semilinear problem, it can be used in order to understand the dynamics of (3.1).

**Lemma 3.2.3.** Consider  $u : \mathbb{R} \rightarrow H_0^1(0, \pi)$  a global bounded solution of (3.1). Suppose that

$$\phi \xleftarrow{t \rightarrow -\infty} u(t) \xrightarrow{t \rightarrow +\infty} \psi,$$

where  $\phi$  and  $\psi$  are two distinct equilibria of (3.1).

Then, either  $\phi = 0$  and  $\psi \neq 0$  or  $\phi \in \{\phi_{j,\lambda}^+, \phi_{j,\lambda}^-\}$  and  $\{\phi_{k,\lambda}^+, \phi_{k,\lambda}^-\}$ , for  $k, j \in \mathbb{N}$ , with  $j^2 < k^2 < \lambda$ .

*Proof.* Since the semigroup associated to (3.1) is gradient, it is clear that if  $\phi = 0$ , then  $\psi \neq 0$ .

Now, suppose that  $\phi \neq 0$ . Recall that the nonlinearity  $f$  in (3.1) is  $C^2(\mathbb{R})$  and also  $f(0) = 0$ . Consequently,

$$f(u) = f(0) + f'(0)u + o(|u|) = u + o(|u|)$$

where  $\frac{o(|s|)}{|s|} \rightarrow 0$  as  $s \rightarrow 0^+$ . Consequently,  $f(u) = g(u)u$ , for some  $g \in C^2(\mathbb{R})$  with  $g(0) = 1$ .

Then, the solution  $u : [0, +\infty) \rightarrow H_0^1(0, \pi)$  of (3.1) is also a global solution of

$$\begin{cases} u_t = u_{xx} + r(t, x)u, \\ u(t, 0) = u(t, \pi) = 0, \end{cases} \quad (3.9)$$

where  $r(t, x) = \lambda g(u(t, x))$  is continuous and well-defined in  $\mathbb{R}^+ \times [0, \pi]$ . Then  $\phi \in \{\phi_{k,\lambda}^+, \phi_{k,\lambda}^-\}$ , for some  $k \in \mathbb{N} \cap (0, \sqrt{\lambda})$ .

Since  $u(t) \rightarrow \phi_k$  as  $t \rightarrow -\infty$  and this convergence is in  $C^1(\mathbb{R})$ , we find  $\tau_0 \in (-\infty, 0]$  such that the set  $\{x \in [0, 1] : u(\tau_0, x) \neq 0\}$  has  $k$  components. Similarly, we find a  $\tau_1 \in (\tau_0, +\infty)$  sufficiently large such that the set  $\{x \in [0, \pi] : u(\tau_1, x) \neq 0\}$  has  $j$  components.

Now, by applying Lemma 3.2.1 to (3.9), it follows that  $k \geq j$ . In fact, this inequality is strict. Otherwise, if  $k = j$ , then either  $\phi = \phi_{j,\lambda}^+$  and  $\psi = \phi_{j,\lambda}^-$  or  $\phi = \phi_{j,\lambda}^-$  and  $\psi = \phi_{j,\lambda}^+$ .

When  $j \in \mathbb{N}$  is even, property  $\phi_j^-(\cdot) = \phi_j^+(\pi - \cdot)$  and then,  $E(\phi_j^-(\cdot)) = E(\phi_j^+(\cdot))$ . Since our problem is gradient, this cannot happen.

When  $j \in \mathbb{N}$  is odd, we make use of the lap-number property given in Theorem 3.2.1. For a global solution  $u(\cdot)$  let

$$\begin{aligned} Q^+(t) &= \{x \in (0, 1) : u(t, x) > 0\}, \\ Q^-(t) &= \{x \in (0, 1) : u(t, x) < 0\}. \end{aligned}$$

In the proof of Theorem 6 in (HENRY, 1985) it is shown that if  $t_1 > t_0$ , then there is an injective map for the connected components of  $Q^+(t_1)$  ( $Q^-(t_1)$ ) to connected components of  $Q^+(t_0)$  ( $Q^-(t_0)$ ). Let, for example,  $u(\cdot)$  be a global solution such that  $u(t) \xrightarrow{t \rightarrow -\infty} \phi_j^-$ ,  $u(t) \xrightarrow{t \rightarrow +\infty} \phi_j^+$ . Since we have convergence in  $C^1([0, \pi])$ , there are  $t_0 < t_1$  such that the number of components of  $Q^+(t_0)$  is equal to  $(j-1)/2$  and the number of components of  $Q^+(t_1)$  is equal to  $(j+1)/2$ . This contradicts the existence of the above injective map. Thus, such heteroclinic connection is impossible. A similar argument (but using  $Q^-(t)$ ) is valid for the connection from  $\phi_j^+$  to  $\phi_j^-$ . □

In (FIEDLER; ROCHA, 1996), the authors pictured the connections in the attractor  $\mathcal{A}_\lambda$  as this nice diagram, where the oriented paths determined by the arrows imply the existence of connections between the initial and the final equilibria of the path:

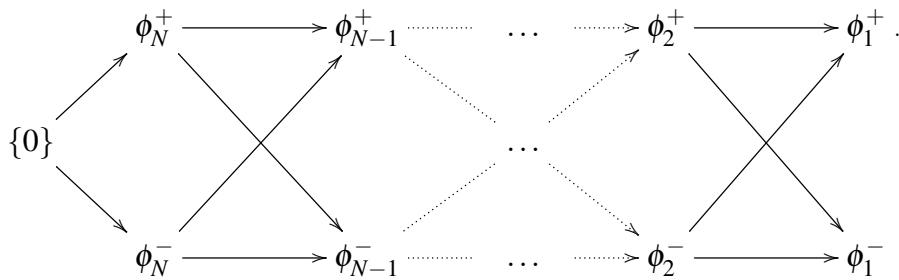

Now, fix  $n \in \mathbb{N}$  and define the sets  $D^n = \{x = (x_1, \dots, x_n) \in \mathbb{R}^n : x_1^2 + \dots + x_n^2 \leq 1\}$  and  $S^{n-1} = \{x = (x_1, \dots, x_n) \in \mathbb{R}^n : x_1^2 + \dots + x_n^2 = 1\}$ . Consider the following problem

$$\begin{cases} \dot{\theta} = Q\theta - \langle Q\theta, \theta \rangle \theta, \theta \in S^{n-1}, \\ \dot{r} = r(1-r), r \in [0, 1], \end{cases} \quad (3.10)$$

for

$$Q = \begin{bmatrix} 1 & 0 & \dots & 0 \\ 0 & \frac{1}{2} & & \\ \vdots & & \ddots & \\ 0 & & & \frac{1}{n} \end{bmatrix}.$$



It can be shown that problem (3.10) defines a flow  $\psi^n : \mathbb{R} \times D^n \rightarrow D^n$ .

For  $\lambda \in (n^2, (n+1)^2)$ ,  $n \in \mathbb{N}$ , it has been proved in (MISCHAIKOW, 1995, Theorem 1.1) that the dynamics inside the attractor of (3.1) is conjugated to the dynamics defined by  $\psi^n$  on  $D^n$ .

### 3.3 Identifying the structure of a global attractor

In (MISCHAIKOW, 1995), the author shows that problems satisfying some conditions have an attractor with the same structure of the Chafee-Infante problem. The conditions for such problems are the following:

**(A1)** Consider a sequence  $\{\lambda_n\}_{n \in \mathbb{N}} \in \mathbb{R}^+$ , with  $\lambda_n < \lambda_{n+1}$ , for all  $n \in \mathbb{N}$ . Suppose that we can define a continuous parameterized family of semiflows  $\varphi_\lambda : \mathbb{R}^+ \times X \rightarrow X$ , for  $\lambda \in \mathbb{R}^+$ .

For each  $\lambda > 0$ , we also assume that  $\varphi_\lambda$  has a global attractor  $\mathcal{A}_\lambda$  and the map

$$\varphi_\lambda : \mathbb{R} \times \mathcal{A}_\lambda \rightarrow \mathcal{A}_\lambda$$

defines a flow.

**(A2)** For each  $\lambda \in (\lambda_n, \lambda_{n+1})$ , the attractor  $\mathcal{A}_\lambda$  admits a Morse decomposition

$$M_\lambda(\mathcal{A}_\lambda) = \{M_\lambda(j^\star) : j \in \{0, \dots, N-1\}, \star \in \{+, -\}\} \cup \{M_\lambda(n)\}.$$

$M_\lambda(n)$  represents the zero equilibrium for  $\lambda \in (\lambda_n, \lambda_{n+1})$ . Moreover,

$$\begin{aligned} j^\pm < k^\pm \text{ for } j, k \in \{0, \dots, N-1\} &\iff j < k \text{ in } \mathbb{N}, \\ j^\pm < N, \text{ for all } j \in \{0, \dots, N-1\}. \end{aligned}$$

is an admissible order.

**(A3)** We assume that we have the following homology index, for  $\lambda \in (\lambda_n, \lambda_{n+1})$ :

$$H^k(M_\lambda(j^\star)) \simeq \begin{cases} \mathbb{Z}, & \text{if } k = j, \\ 0, & \text{otherwise,} \end{cases} \quad \text{and} \quad H^k(M_\lambda(n)) \simeq \begin{cases} \mathbb{Z}, & \text{if } k = n, \\ 0, & \text{otherwise,} \end{cases}$$

for  $j \in \{0, \dots, n-1\}$  and  $\star \in \{+, -\}$ .

**(A4)** For  $\lambda \in (\lambda_n, \lambda_{n+1})$ , the connection matrix is given by

$$\Delta_\lambda = \begin{bmatrix} 0 & D_1^\lambda & 0 & \dots & 0 \\ & 0 & D_2^\lambda & \ddots & \vdots \\ \vdots & & \ddots & \ddots & 0 \\ & & & 0 & D_n^\lambda \\ 0 & & & \dots & 0 \end{bmatrix}$$

where the submatrices

$$D_j^\lambda : H^j(M_\lambda(j^-)) \oplus H^j(M_\lambda(j^+)) \rightarrow H^{j-1}(M_\lambda((j-1)^-)) \oplus H^{j-1}(M_\lambda((j-1)^+))$$

can be written as  $D_j^\lambda = \begin{bmatrix} 1 & 1 \\ -1 & -1 \end{bmatrix}$  and

$$D_n^\lambda : H^n(M_\lambda(n)) \rightarrow H^{n-1}(M_\lambda((n-1)^-)) \oplus H^{n-1}(M_\lambda((n-1)^+))$$

can be written as  $D_n^\lambda = \begin{bmatrix} 1 \\ -1 \end{bmatrix}$ .

In order to obtain the structure of the global attractor for the problem (5.1), we will present Theorem 1.2, (MISCHAIKOW, 1995). In order to do that, we need to define an auxiliary problem. Fix  $n \in \mathbb{N}$ . Denote by  $\|\cdot\|_{\mathbb{R}^n}$  and  $\langle \cdot, \cdot \rangle$  the norm and inner product, respectively, of the Euclidean space  $\mathbb{R}^n$ . Consider the subsets

$$D^n = \{x = (x_1, \dots, x_n) \in \mathbb{R}^n : \|x\|_{\mathbb{R}^n} \leq 1\},$$

$$S^{n-1} = \{x = (x_1, \dots, x_n) \in \mathbb{R}^n : \|x\|_{\mathbb{R}^n} = 1\}$$

and, for  $j = 1, \dots, n$ , define  $e_j^\pm = (\delta_{1j}^\pm, \dots, \delta_{nj}^\pm)$  with  $\delta_{jj} = \pm 1$  and  $\delta_{kj}^\pm = 0$ , if  $k \neq j$ . Moreover, we have the following result

**Theorem 3.3.1** (Theorem 1.2, (MISCHAIKOW, 1995)). Assuming (A1)-(A4) and  $\lambda \in (\lambda_n, \lambda_{n+1})$ , there exists a flow  $\tilde{\varphi}_\lambda$  given by a time-reparameterization of  $\varphi_\lambda$  and a continuous surjective map  $g_\lambda : \mathcal{A}_\lambda \rightarrow D^n$ , satisfying  $M(j^\pm) = g_\lambda^{-1}(\{e_{j+1}^\pm\})$ , for  $0 \leq j \leq n-1$ , and  $M(n) = g_\lambda^{-1}(\{0\})$ , such that the following diagram commutes:

$$\begin{array}{ccc} \mathbb{R} \times \mathcal{A}_\lambda & \xrightarrow{I_{\mathbb{R}} \times g_\lambda} & \mathbb{R} \times D^n \\ \tilde{\varphi}_\lambda \downarrow & & \downarrow \psi^n \\ \mathcal{A}_\lambda & \xrightarrow{g} & D^n \end{array}$$

where  $I_{\mathbb{R}}$  represents the identity in  $\mathbb{R}$ .

### 3.4 A non-autonomous Chafee-Infante problem

In this section, we will describe some results on the structure of a non-autonomous parabolic problem. This problem was the object of study in (CARVALHO; LANGA; ROBINSON, 2012; CARVALHO; LANGA; ROBINSON, 2013; BROCHE; CARVALHO; VALERO, 2019).

Although this problem is not close to an autonomous problem, we can also find non-autonomous equilibria for it.

The study of the structure of the attractor for non-autonomous problems is a very difficult subject. Part of the challenge is that, unlike what occurs in the autonomous case, we do not always

know how to identify invariant sets that play an essential role in the dynamics. For instance, the existence of equilibria or periodic solutions is possible, but we do not expect the dynamics to depend only on these particular types of solutions.

Thinking about that, the authors in (CARVALHO; LANGA; ROBINSON, 2012) considered the following non-autonomous equation

$$\begin{cases} u_t = u_{xx} + \lambda u - \beta(t)u^3, & x \in (0, \pi), t > s, \\ u(t, 0) = u(t, \pi) = 0, & t \geq s, \\ u(0, \cdot) = u_0(\cdot) \in H_0^1(0, \pi) \end{cases} \quad (3.11)$$

where  $\lambda > 0$  is a parameter and  $\beta : \mathbb{R} \rightarrow [b_1, b_2]$  is a globally Lipschitz function and  $b_2 > b_1 > 0$ . The authors (CARVALHO; LANGA; ROBINSON, 2012) have shown that we have a process  $\{S_\beta(t, s) : t \geq s\} \subset C(H_0^1(0, \pi))$  related to (3.11) which admits a pullback attractor  $\{\mathcal{A}(t) : t \in \mathbb{R}\}$ .

When  $\beta(\cdot) \equiv b$ , for some  $b > 0$ , we have the Chafee-Infante problem, presented in Chapter 3. If  $\beta(\cdot)$  is sufficiently close to a constant, the result of Theorem 3.4.2 was already known, see (BORTOLAN; CARVALHO; LANGA, 2020).

The idea to show the existence of the non-autonomous equilibria is to use comparison between the solutions of (3.11) and (3.11) with  $\beta(\cdot)$  replaced by  $\gamma_1(\cdot) = b_1$  and  $\gamma_2(\cdot) = b_2$ . For  $j = 1, 2$ , denote by  $\{T_j(t) : t \geq 0\}$  the semigroup related to

$$\begin{cases} u_t = u_{xx} + \lambda u - b_j u^3, & x \in (0, \pi), t > s \\ u(t, 0) = u(t, \pi) = 0, & t \geq s \\ u(0, \cdot) = u_0(\cdot) \in H_0^1(0, \pi). \end{cases}$$

In this case, we have the following comparison result:

**Theorem 3.4.1.** For  $u_0 \leq u_1 \leq u_2$  in  $H_0^1(0, \pi)$ , we have

$$\begin{aligned} T_j(t)u_0 &\leq T_j(t)u_1, \text{ for all } t > 0, (j = 1, 2) \\ T_2(t-s)u_0 &\leq S(t, s)u_1 \leq T_1(t-s)u_2, \text{ for all } t > s. \end{aligned}$$

For  $i \in \mathbb{N}$  and  $j = 1, 2$ , denote by  $\phi_{i, b_j}^+$  (resp.  $\phi_{i, b_j}^-$ ) the equilibrium of  $\{T_j(t) : t \geq 0\}$  that satisfies  $(\phi_{i, b_j}^+)'(0) > 0$  (resp.  $(\phi_{i, b_j}^-)'(0) < 0$ ) and has  $i + 1$  zeros in  $[0, \pi]$ . It can be easily seen that  $\phi_{i, b_1}^+ = \left(\frac{b_2}{b_1}\right)^{\frac{1}{2}} \phi_{i, b_2}^+$  and  $\phi_{i, b_1}^- = \left(\frac{b_2}{b_1}\right)^{\frac{1}{2}} \phi_{i, b_2}^-$ .

For  $i \in \mathbb{N}$ , we define the sets

$$X_i^+ = \left\{ u \in H_0^1(0, \pi) : \min\{\phi_{i, b_1}^+, \phi_{i, b_2}^+\} \leq u \leq \max\{\phi_{i, b_1}^+, \phi_{i, b_2}^+\}, u(x) = -u(x - \frac{\pi}{i}), x \in [\frac{\pi}{i}, \pi], \right. \\ \left. \text{and } u(x) = u(\frac{\pi}{i} - x), x \in [0, \frac{\pi}{i}] \right\}$$

and

$$X_i^- = \left\{ \begin{array}{l} u \in H_0^1(0, \pi) : \min\{\phi_{i,b_1}^-, \phi_{i,b_2}^-\} \leq u \leq \max\{\phi_{i,b_1}^-, \phi_{i,b_2}^-\}, u(x) = -u(x - \frac{\pi}{i}), x \in [\frac{\pi}{i}, \pi] \\ \text{and } u(x) = u(\frac{\pi}{i} - x), x \in [0, \frac{\pi}{i}] \end{array} \right\}.$$

Using the comparison theorem above, we can show that the sets  $X_i^\pm$  are nonempty if  $\lambda > i^2$ . In fact, we have  $S(t, s)X_i^+ \subset X_i^+$  and  $S(t, s)X_i^- \subset X_i^-$ , for all  $t \geq s$ . Since  $X_i^\pm$  are bounded and positively invariant, the restriction of  $\{S(t, s) : t \geq s\}$  to  $X_i^\pm$  guarantees the existence of invariant sets  $\{A_i^+(t) : t \in \mathbb{R}\} \subset X_i^+$  and  $\{A_i^-(t) : t \in \mathbb{R}\} \subset X_i^-$ . Even more, it can also be show that, for each  $t \in \mathbb{R}$ ,  $A_i^+(t) = \{\xi_i^+(t)\}$  and  $A_i^-(t) = \{\xi_i^-(t)\}$ , where  $\xi_i^+ : \mathbb{R} \rightarrow X$  (resp.  $\xi_i^- : \mathbb{R} \rightarrow X$ ) is a global solution of  $\{S(t, s) : t \geq s\}$  in  $X_i^+$  (resp.  $X_i^-$ ). Thus we have the following result

**Theorem 3.4.2.** (CARVALHO; LANGA; ROBINSON, 2012, Theorem 8)

For  $\lambda \in (N^2, (N+1)^2]$ , the problem (3.11) admits  $2N$  non-zero non-autonomous equilibria.

### 3.5 Further comments and open problems

In this chapter, we have presented the results on the Chafee-Infante problem and its non-autonomous variation. The Chafee-Infante problem was a revolutionary example in the area, since it has allowed pursuing further investigations on the inner structure. This is usually a very difficult subject and there are no clear techniques that work generally.

There are several studies inspired by the articles (CHAFEE; INFANTE, 1974) and (CHAFEE; INFANTE, 1974/75). This problem was an inspiration on the development of the topological and the geometrical theory of several other articles and was the object of interest of many authors.

As we have seen, the lap-number property is essential to understand the dynamics inside the attractor. But this property is restricted to problems in the one-dimensional setting. Thus, the study of bifurcation of equilibria of a model such Chafee-Infante in an open domain  $\Omega \subset \mathbb{R}^n$ ,  $n \geq 2$ , is far from being a clarified problem.

Now, the construction of the non-autonomous equilibria of (3.11) is made by using invariant regions determined by autonomous Chafee-Infante problems. In fact, the result of (CARVALHO; LANGA; ROBINSON, 2012) is more complete than we have mentioned. For instance, the authors proved that if  $n^2 < \lambda \leq (n+1)^2$ , for some  $n \in \mathbb{N}$ , the problem (3.11) admits exactly  $2n$  non-autonomous equilibria. In fact, the authors in the cited publication have shown that  $\xi_j^\kappa(\cdot)$  is the only global solution of (3.11) inside  $X_j^\kappa$ , for  $1 \leq j \leq n$  and  $\kappa \in \{+, -\}$ .

In the project of my PhD, we described our interest in understanding better the local properties of the non-autonomous equilibria of (3.11). To be more precise, it is one of our interests to show that all the non-autonomous equilibria are hyperbolic. In the case that  $\beta(\cdot)$  is

very close to a positive constant (and far from zero), the hyperbolicity of these global solutions are known. But generally we do not know the answer yet.

We have developed, with other collaborators, a work on inertial manifolds (see (CARVALHO; LAPPICY; OLIVEIRA-SOUSA, 2021)) that may be useful in the study of hyperbolicity for non-autonomous equilibria. So far, we were not able to obtain the desired result. We expect to continue our investigation on this subject.

In the next chapters, we will consider problems inspired by the Chafee-Infante problem: a non-autonomous nonlocal quasilinear version (see Chapter 4), an autonomous nonlocal quasilinear version (see Chapter 5) and a multivalued problem (see Chapter 6).





## A NON-AUTONOMOUS PARABOLIC PROBLEM

---

The study of non-autonomous problems can be very challenging and they differ from the autonomous in several aspects. When we consider the attractor for a non-autonomous problem, we also have to take in account the effects caused on the time dependence. For instance, the structure of the attractor is more difficult since we may not have stationary points that characterize the dynamics.

Although we can find several results in the literature about the existence of pullback attractor or results on stability, we cannot find many results on the finer structure of a pullback attractor. The authors in (CARVALHO; LANGA; ROBINSON, 2012) proposed a concept called “non-autonomous equilibria” which will be a special class of solutions that behave such as the equilibria in the autonomous gradient systems.

The inspiration to define the non-autonomous equilibria (see Definition 2.3.21) had come from the fact that autonomous gradient dynamical systems are robust under small non-autonomous perturbations. In this context, the appearance of these classes of solutions is natural. In (CARVALHO; LANGA; ROBINSON, 2012), the authors were able to show the existence of such a class of solution even when we do not consider a small Lipschitz perturbation.

In this chapter, we will explore a non-autonomous and nonlocal quasilinear problem

$$\begin{cases} u_t - a(\|u_x\|^2)u_{xx} = \lambda u - \beta(t)u^3, & x \in (0, \pi), t > s, \\ u(0, t) = u(\pi, t) = 0, & t \geq s, \\ u(\cdot, s) = u_0(\cdot) \in H_0^1(0, \pi), \end{cases} \quad (4.1)$$

where  $\|u_x\|^2 = \int_0^\pi |u_x(x)|^2 dx$  (usual norm of the Hilbert space  $H_0^1(0, \pi)$ ),  $\lambda \in (0, \infty)$  is a parameter,  $a : \mathbb{R}^+ \rightarrow [m, M]$  is a locally Lipschitz function,  $0 < m < M$ , and  $\beta : \mathbb{R}^+ \rightarrow [b_1, b_2]$  is a globally Lipschitz function, for  $0 < b_1 < b_2$ .

If we consider  $a(\cdot) \equiv 1$ , we find the non-autonomous Chafee-Infante problem that we presented previously (see Section 3.4). In what follows we will comment about the differences we find in considering (4.1) with non-constant  $a(\cdot)$ .

We will show this problem is globally well-posed and admits non-autonomous equilibria.

## 4.1 A non-autonomous and nonlocal parabolic problem

In this section, we will show that (4.1) is globally well-posed and it defines a process. First, consider the following

$$\begin{cases} w_\tau = w_{xx} + \frac{1}{a(\|w_x\|^2)} \left[ \lambda w - \beta \left( s + \int_s^\tau \frac{1}{a(\|w_x(\cdot, \theta)\|^2)} d\theta \right) w^3 \right], & x \in (0, \pi), \tau > s, \\ w(0, \tau) = w(\pi, \tau) = 0, & \tau \geq s, \\ w(\cdot, s) = u_0(\cdot) \in H_0^1(0, \pi) \end{cases} \quad (4.2)$$

with the same assumptions of (4.1).

**Lemma 4.1.1.** The problem (4.2) is locally well-posed in  $H^1(0, \pi)$ .

*Proof.* Consider the linear operator  $A : D(A) \subset L^2(0, \pi) \rightarrow L^2(0, \pi)$ , for  $D(A) = H^2(0, \pi) \cap H_0^1(0, \pi)$  and  $Au = u_{xx}$ , for  $u \in D(A)$ . The operator  $A$  is self-adjoint and it has compact resolvent. In particular, the operator  $-A$  is sectorial and we may define the fractional power spaces  $\{X^\theta : \theta > 0\}$ , where  $X = L^2(0, \pi)$  and  $X^1 = H_0^2(0, \pi) \cap H_0^1(0, \pi)$ . Consequently,  $X^{\frac{1}{2}} = H_0^1(0, \pi)$ .

Consider a pair  $(t_0, u_0) \in \mathbb{R}^+ \times X^{\frac{1}{2}}$ . For  $T > t_0$  and  $R > 0$ , define the space  $\mathcal{B} \subset (C([t_0, T]; H_0^1(0, \pi)), \|\cdot\|)$ , where  $\|u\| := \sup_{t \in [t_0, T]} \|u\|_{H_0^1(0, \pi)}$ , satisfying  $\|u - u_0\| \leq R$  for  $u \in \mathcal{B}$ . It is easy to see that  $(\mathcal{B}, \|\cdot\|)$  is a complete metric space.

Define the function

$$\begin{aligned} f : \mathcal{B} &\rightarrow C([t_0, T]; L^2(0, \pi)) \\ w(\cdot) &\mapsto f(w)(\cdot) \end{aligned}$$

given by

$$f(w)(r) = \frac{\lambda w(r) - \beta(\tau_w(r))w^3(r)}{a(\|w_x(r)\|^2)},$$

where  $\tau_w(r) = t_0 + \int_{t_0}^r a(\|w_x\|^2)^{-1} ds$ ,  $r \in [t_0, T]$ .

For each  $v \in C([t_0, T], H_0^1(0, \pi))$  and  $r, s \in [t_0, T]$ ,  $s > r$ ,

$$\begin{aligned} \|f(v)(s) - f(v)(r)\| &\leq \frac{\lambda}{a(\|v_x(s)\|^2)} \|v(s) - v(r)\| + \left( \frac{\lambda}{a(\|v_x(s)\|^2)} - \frac{\lambda}{a(\|v_x(r)\|^2)} \right) \|v(r)\| \\ &\quad + \|\beta(\tau_v(s))[v^3(s) - v^3(r)]\| + \|\beta(\tau_v(s)) - \beta(\tau_v(r))\| \|v^3(r)\| \\ &\leq \frac{\lambda}{m} \|v(s) - v(r)\| + \left( \frac{\lambda[a(\|v_x(r)\|^2) - a(\|v_x(s)\|^2)]}{m^2} \right) \|v(r)\| \\ &\quad + b_2 \|v^3(s) - v^3(r)\| + |\beta(\tau_v(s)) - \beta(\tau_v(r))| \|v^3(r)\|. \end{aligned}$$



Now, denote by  $L_a$  (resp.  $L_\beta$ ) the Lipschitz constant of  $a(\cdot)$  (resp.  $\beta(\cdot)$ ) in  $B_{X^{\frac{1}{2}}}(0, R)$ . We have the following

$$\begin{aligned} |a(\|v_x(r)\|^2) - a(\|v_x(s)\|^2)| &\leq L_a(\|v_x(r)\|^2 - \|v_x(s)\|^2) \leq 2L_a R^2 \|v_x(r) - v_x(s)\|, \\ \|v^3(s) - v^3(r)\| &\leq 3\|v\|_{L^\infty(0, \pi)}^2 \|v(s) - v(r)\| \leq 3\|v\|_{L^\infty(0, \pi)}^2 \|v(s) - v(r)\|_{H_0^1(0, \pi)}, \\ \|\beta(\tau_v(s)) - \beta(\tau_v(r))\| &\leq L_\beta |\tau_v(s) - \tau_v(r)| \leq L_\beta \int_r^s a(\|v_x(l)\|^2)^{-1} dl \leq \frac{L_\beta |r - s|}{m}. \end{aligned}$$

From the above inequalities and using the Sobolev's inequalities, we find a  $C = C(R) > 0$  such that

$$\|f(v)(s) - f(v)(r)\| \leq C(R) \left( |s - r| + \|v(s) - v(r)\|_{H_0^1(0, \pi)} \right).$$

By similar calculations, we can show that there is a  $C(R) > 0$  for which

$$\|f(v)(r) - f(w)(r)\| \leq C(R) \|v(r) - w(r)\|_{H_0^1(0, \pi)}, \quad r \in [t_0, T],$$

for all  $v, w \in \mathcal{B}$ .

Define the function  $\mathcal{G} : \mathcal{B} \rightarrow \mathcal{B}$  by

$$\mathcal{G}(u)(t) = e^{A(t-t_0)} u_0 + \int_{t_0}^t e^{A(t-s)} f(s, u(s)) ds, \quad t \in [t_0, T].$$

We are able to show, under the same techniques applied on the proof of Theorem 2.3.17 that, by proper choices of  $T$  and  $R$ , the map  $\mathcal{G} : \mathcal{B} \rightarrow \mathcal{B}$  is a contraction.

In other words, there is a  $w(\cdot) = w(\cdot, t_0, u_0) \in C([t_0, T(t_0)]; H_0^1(0, \pi))$  satisfying

$$u(t) = e^{A(t-t_0)} u_0 + \int_{t_0}^t e^{A(t-s)} f(s, u(s)) ds.$$

Hence, using Lemma 2.3.15,  $w$  is a solution of (4.2) with  $w(t_0) = u_0$ .  $\square$

## 4.2 Global well-posedness

In this section, we will use the knowledge we have of (4.2) in order to obtain the global well-posedness of solutions for the quasilinear problem (4.1). Even more, we will show that the problem also generates an evolution process.

**Proposition 4.2.1.** Problem (4.2) is globally well-posed in  $H_0^1(0, \pi)$ .

*Proof.* Let  $(t_0, u_0) \in H_0^1(0, \pi)$ . Using Lemma 4.1.1, there is a solution  $u : [t_0, T] \rightarrow H_0^1(0, \pi)$ ,  $T > t_0$ , of (4.2). By the variation of constants formula, a solution of (4.2) with  $u(t_0) = u_0$  satisfies

$$u(t) = e^{A(t-t_0)} u_0 + \int_{t_0}^t e^{A(t-s)} \left( \frac{\lambda u(s) - \beta(\tau_u(s)) u^3(s)}{a(\|u_x(s)\|^2)} \right) ds$$

as long as the solution exists. Then, for  $t \in (t_0, t_0 + \tau]$ , we have

$$\|u(t)\|_{X^{\frac{1}{2}}} \leq e^{-(t-t_0)} \|u_0\|_{X^{\frac{1}{2}}} + C \int_{t_0}^t e^{-(t-s)} (t-s)^{-\frac{1}{2}} \|u(s)\|_{X^{\frac{1}{2}}} ds$$

since  $f$  is locally Lipschitz continuous. If we denote  $\psi(s) = e^{-(s-t_0)} \|u(s)\|_{X^{\frac{1}{2}}}$ ,  $s \in [t_0, t]$ , we have the following

$$\psi(t) \leq \|u_0\|_{X^{\frac{1}{2}}} + C \int_{t_0}^t (t-s)^{-\frac{1}{2}} \psi(s) ds.$$

Applying the Singular Gronwall's Lemma (Lemma 2.3.16) to we are able to conclude that

$$\sup_{t \in [t_0, t_0 + \tau)} \|u(t)\|_{X^{\frac{1}{2}}} < +\infty.$$

Consequently, the solution  $u(\cdot, t_0, u_0)$  exists for all time, by Theorem 2.3.18. This is a consequence of the fact that the variation of constants formula is well-defined as long as the solution is bounded.  $\square$

**Theorem 4.2.2.** Problem (4.1) is continuous with respect to initial data, that is, for each  $\varepsilon > 0$ , there is a  $\delta \in (0, \varepsilon)$  such that  $\|u_1 - u_2\|_{H_0^1(0, \pi)} < \delta$ , we have that the solutions  $u(\cdot, s, u_j)$  of (4.1) with  $u(s, s, u_j) = u_j$ ,  $j = 1, 2$ , satisfy  $\|u(t, s, u_1) - u(t, s, u_2)\|_{H_0^1(0, \pi)} < \varepsilon$ , for  $t \in [s, s + \delta)$ .

*Proof.* Fix  $\varepsilon > 0$  and  $(s, u_1)$ . Just for simplicity, denote  $u_j(\cdot) = u(\cdot, s, u_j)$ , for  $j = 1, 2$ . Define the following function  $\tau_j(t) = s + \int_s^t a(\|u_j(l)\|_x^2) dl$ , for  $t > s$ ,  $j = 1, 2$ .

For  $j = 1, 2$  and  $w_j(\tau_j(t)) = u_j(t)$ ,  $t > s$ , we have the following

$$w_j(\tau_j(t)) = e^{A(\tau_j(t)-s)} u_j + \int_s^{\tau_j(t)} e^{A(\tau_j(t)-r)} f(r, w_j(r)) dr.$$

We will show that, for each  $T > 0$ , there is a constant  $C = C(T) > 0$  such that

$$\|w_1(\tau) - w_2(\tau)\|_{H_0^1(0, \pi)} \leq C \|u_1 - u_2\|_{H_0^1(0, \pi)}, \text{ for } \tau \in [s, T].$$

In fact,

$$\begin{aligned} \|w_1(\tau) - w_2(\tau)\|_{X^{\frac{1}{2}}} &\leq \|e^{A(\tau-s)} [u_1 - u_2]\|_{X^{\frac{1}{2}}} + \left\| \int_s^\tau e^{A(\tau-r)} [f(r, w_1(r)) - f(r, w_2(r))] dr \right\|_{X^{\frac{1}{2}}} \\ &\leq e^{-(\tau-s)} \|u_1 - u_2\|_{X^{\frac{1}{2}}} + \int_s^\tau e^{-(\tau-r)} (\tau-r)^{-\frac{1}{2}} \|f(r, w_1(r)) - f(r, w_2(r))\| dr \\ &\leq e^{-(\tau-s)} \|u_1 - u_2\|_{X^{\frac{1}{2}}} + \int_s^\tau e^{-(\tau-r)} (\tau-r)^{-\frac{1}{2}} C_f \|w_1(r) - w_2(r)\|_{X^{\frac{1}{2}}} dr, \end{aligned}$$

where  $C_f$  represents the Lipschitz constant of  $f$  in solutions of (4.2) (the solutions are uniformly bounded, by previous results). For  $r \in [s, \tau]$ , define  $\psi(r) = e^{r-s} \|w_1(r) - w_2(r)\|_{H_0^1(0, \pi)}$ . By the previous inequality, we have

$$\psi(\tau) \leq \|u_1 - u_2\|_{H_0^1(0, \pi)} + C_f \int_s^\tau (\tau-r)^{-\frac{1}{2}} \psi(r) dr,$$

and, by the Singular Gronwall's Lemma (Lemma 2.3.16) we find  $\psi(\tau) \leq 2\|u_1 - u_2\|_{H_0^1(0,\pi)} e^{K\tau}$ , for  $K = 4\pi C_f^2$ . Thus

$$\|w_1(\tau) - w_2(\tau)\|_{H_0^1(0,\pi)} \leq 2e^{(K-1)(\tau-s)} \|u_1 - u_2\|_{H_0^1(0,\pi)}. \quad (4.3)$$

The above inequality shows that problem (4.2) is continuous with respect to initial data.

Observe that, for  $i = 1, 2$

$$\tau_i(t) - s = \int_s^t a(\|(u_i)_x(r)\|^2) dr \leq M(t-s), \text{ for } t \geq s. \quad (4.4)$$

Then, for  $i \in \{1, 2\}$ ,

$$\|w_1(\tau_i(t)) - u_1\|_{H_0^1(0,\pi)} \leq \| [e^{A(\tau_i(t)-s)} - I] u_1 \|_{H_0^1(0,\pi)} + \int_s^{\tau_i(t)} \| e^{A(\tau_i(t)-r)} f(r, w_1(r)) \|_{H_0^1(0,\pi)} dr.$$

By the previous theorem, there is a  $C > 0$  such that  $\sup_{r \geq s} \|w_1(r)\|_{H_0^1(0,\pi)} \leq C$ . Hence,

$$\|w_1(\tau_i(t)) - u_1\|_{H_0^1(0,\pi)} \leq \| [e^{A(\tau_i(t)-s)} - I] u_1 \|_{H_0^1(0,\pi)} + C \int_0^{\tau_i(t)-s} e^{-l} l^{-\frac{1}{2}} dl, \quad i \in \{1, 2\}. \quad (4.5)$$

Choose a  $\delta_1 > 0$  such that

$$\sup_{r \in [0, M\delta_1]} \| [e^{Ar} - I] u_1 \|_{H_0^1(0,\pi)} + C \int_0^{M\delta_1} e^{-l} l^{-\frac{1}{2}} dl < \frac{\varepsilon}{3}. \quad (4.6)$$

Also choose  $\delta_2 > 0$  such that

$$2 \max\{e^{(K-1)M\delta_1}, 1\} \delta_2 < \frac{\varepsilon}{3}. \quad (4.7)$$

Let  $\delta = \min\{\delta_1, \delta_2\} > 0$ . We want to show that

$$\|u_1(t) - u_2(t)\|_{H_0^1(0,\pi)} < \varepsilon,$$

if  $t \in [s, s + \delta)$  and  $\|u_1 - u_2\|_{H_0^1(0,\pi)} < \delta$ .

In fact, for  $t \in [s, s + \delta)$  and  $u_2 \in H_0^1(0, \pi)$  with  $\|u_1 - u_2\|_{H_0^1(0,\pi)} < \delta$ , we have

$$\begin{aligned} \|u_1(t) - u_2(t)\|_{H_0^1(0,\pi)} &= \|w_1(\tau_1(t)) - w_1(\tau_2(t))\|_{H_0^1(0,\pi)} \\ &\leq \|w_1(\tau_1(t)) - u_1\|_{H_0^1(0,\pi)} + \|w_1(\tau_2(t)) - u_1\|_{H_0^1(0,\pi)} \\ &\quad + \|w_2(\tau_2(t)) - w_1(\tau_2(t))\|_{H_0^1(0,\pi)}. \end{aligned}$$

Combining (4.5), (4.4) and (4.6), we can easily see that, for  $i = 1, 2$ ,

$$\|w_1(\tau_i(t)) - u_1\|_{H_0^1(0,\pi)} \leq \sup_{r \in [0, M(t-s)]} \| [e^{Ar} - I] u_1 \|_{H_0^1(0,\pi)} + C \int_0^{M(t-s)} e^{-l} l^{-\frac{1}{2}} dl < \frac{\varepsilon}{3}.$$

Note also that, for (4.3), (4.4) (4.7), we have

$$\|w_2(\tau_2(t)) - w_1(\tau_2(t))\|_{H_0^1(0,\pi)} \leq 2 \max\{e^{M(K-1)(t-s)}, 1\} \|u_1 - u_2\|_{H_0^1(0,\pi)} < \frac{\varepsilon}{3}.$$

Therefore, the result follows.  $\square$

Consider  $\{U(t, s) : t \geq s\} \subset C(H_0^1(0, \pi))$  evolution process associated with (4.2).

**Theorem 4.2.3.** Problem (4.1) defines a process  $\{S(t, s) : t \geq s\} \subset C(H_0^1(0, \pi))$ .

*Proof.* Let  $u_0 \in H_0^1(0, \pi)$  and  $s \in \mathbb{R}$ . By Proposition 4.2.1, there is a solution  $w : [s, +\infty) \rightarrow H_0^1(0, \pi)$  of (4.2) satisfying  $w(s) = u_0$ . Now, for  $\tau \in [s, +\infty)$ , consider  $u(t) = w(\tau)$ , where  $t = t_w(\tau) = s + \int_s^\tau \frac{1}{a(\|w_x(r)\|^2)} dr$ ,  $t \geq s$ . It is easy to see that  $u$  is a solution of (4.1) with  $u(s) = u_0$ .

Now, consider  $v : [s, +\infty) \rightarrow X$  solution of (4.1) with  $v(s) = u_0$ . We want to show that  $v(t) = u(t)$ , for all  $t \geq s$ . With this objective, consider  $z : [s, +\infty) \rightarrow H_0^1(0, \pi)$  the solution of (4.2) with  $z(s) = u_0$ . By (4.3), it follows that  $z(\tau) = v(\tau)$ , for all  $\tau \in [s, +\infty)$ . As consequence, we have

$$t_z(\tau) = s + \int_s^\tau \frac{1}{a(\|z_x(r)\|^2)} dr = s + \int_s^\tau \frac{1}{a(\|v_x(r)\|^2)} dr = t_v(\tau), \quad \tau \in [s, +\infty).$$

Therefore, we have  $u(t) = v(t)$ , for all  $t \geq s$ .

The continuity of (4.1) with respect to the initial data was proved on Theorem 4.2.2. □

### 4.3 Existence of pullback attractor

In this section, we will show that  $\{U(t, s) : t \geq s\}$  and  $\{S(t, s) : t \geq s\}$  admit a pullback attractor.

**Lemma 4.3.1.** The process  $\{U(t, s) : t \geq s\}$  is pullback asymptotically compact.

*Proof.* Consider  $\tau \in \mathbb{R}$ , a bounded sequence  $\{x_n\}_{n \in \mathbb{N}} \in X$  and  $\{s_n\}_{n \in \mathbb{N}} \in \mathbb{R}$  with  $t \geq s_k \rightarrow -\infty$  as  $k \rightarrow +\infty$ .

We want to show that for  $t \leq \tau$ , the sequence  $\{S(t, s_n)x_n\}_{n \in \mathbb{N}}$  is precompact in  $H_0^1(0, \pi)$ . Consider again the operator  $A$  given in Example 2.3.12 and its family of fractional powers  $\{X^\gamma : 0 < \gamma < 1\}$ . For  $\gamma \in [\frac{1}{2}, 1)$ , we have

$$\begin{aligned} \|S(t, s_n)x_n\|_{X^\gamma} &\leq \|e^{A(t-s_n)}x_n\|_{X^\gamma} + \int_{s_n}^t \|e^{A(t-r)}f(r, S(r, s_n)x_n)\|_{X^\gamma} dr \\ &\leq e^{-(t-s_n)}(t-s_n)^{-(\gamma-\frac{1}{2})} \|x_n\|_{H_0^1(0, \pi)} + \int_{s_n}^t e^{-(t-r)}(t-r)^{-\gamma} \|f(r, S(r, s_n)x_n)\| dr \\ &\leq e^{-(t-s_n)}(t-s_n)^{-(\gamma-\frac{1}{2})} \|x_n\|_{H_0^1(0, \pi)} + C \int_{s_n}^t e^{-(t-r)}(t-r)^{-\gamma} \|S(r, s_n)x_n\|_{H_0^1(0, \pi)} dr \end{aligned}$$

for some constant  $\tilde{C} > 0$ , where we have used that  $X^\gamma \hookrightarrow X^{\frac{1}{2}} = H_0^1(0, \pi)$ .

If we consider  $\gamma = \frac{1}{2}$ , it is easy to see that we can apply the Singular Gronwall's Lemma (Lemma 2.3.16), to find  $\sup\{\|S(t, s_n)x_n\|_{H_0^1(0, \pi)} : n \in \mathbb{N}\} < M$ , for some  $M > 0$ .

Now, if  $\gamma > \frac{1}{2}$ , for  $n \in \mathbb{N}$ ,

$$\begin{aligned} \|S(t, s_n)x_n\|_{X^\gamma} &\leq e^{-(t-s_n)}(t-s_n)^{-(\gamma-\frac{1}{2})}\|x_n\|_{H_0^1(0, \pi)} + CM \int_0^{t-s_n} e^{-(t-r)}(t-r)^{-\gamma} dr \\ &\leq e^{-(t-s_n)}(t-s_n)^{-(\gamma-\frac{1}{2})}\|x_n\|_{H_0^1(0, \pi)} + CM\Gamma(1-\gamma). \end{aligned}$$

and we conclude that  $\{S(t, s_n)x_n\}_{n \in \mathbb{N}}$  is bounded on  $X^\gamma$  and precompact in  $H_0^1(0, \pi)$ .  $\square$

Now, we want to show that we have a comparison of (4.1) with versions of a Chafee-Infante problem. Our aim is to show the existence of nonempty positively invariant regions. Consider the auxiliary initial boundary value problems

$$\begin{cases} z_t = z_{xx} + \frac{\lambda}{m}z - \frac{b_1}{M}z^3, & x \in (0, \pi), t > 0 \\ z(0, t) = z(\pi, t) = 0, & t \geq 0, \\ z(\cdot, 0) = z_0(\cdot) \in H_0^1(0, \pi), \end{cases} \quad (4.8)$$

and

$$\begin{cases} v_t = v_{xx} + \frac{\lambda}{M}v - \frac{b_2}{m}v^3, & x \in (0, \pi), t > 0 \\ v(0, t) = v(\pi, t) = 0, & t \geq 0, \\ v(\cdot, 0) = v_0(\cdot) \in H_0^1(0, \pi). \end{cases} \quad (4.9)$$

Both problems are globally well-posed and define a semigroup, see Chapter 3. Denote by  $\{T_1(t) : t \geq 0\}$  the semigroup associated with (4.8) and by  $\{T_2(t) : t \geq 0\}$  the semigroup associated with (4.9). Now, denote by  $\{U(t, s) : (t, s) \in \mathcal{P}\}$  the evolution process associated with (4.2).

Recall that  $H_0^1(0, \pi)$  is a pre-ordered space by the relation: for  $u, v \in H_0^1(0, \pi)$ ,  $u \leq v$  if  $u(x) \leq v(x)$  a. e. in  $(0, \pi)$ . Define the set  $\mathcal{C} = \{u \in H_0^1(0, \pi) : u \geq 0\}$ , which we call it the positive cone of  $H_0^1(0, \pi)$ .

**Theorem 4.3.2.** With the above notation, if  $u_0 \leq u_1 \leq u_2$  in  $H_0^1(0, \pi)$ , then

$$T_2(t-s)u_0 \leq U(t, s)u_1 \leq T_1(t-s)u_2, \quad \forall (t, s) \in \mathcal{P}. \quad (4.10)$$

*Proof.* Observe that, given  $R > 0$  there exists  $\gamma(R) > 0$  such that for  $t \in \mathbb{R}$ ,  $\gamma \in \mathbb{R}^+$  and  $0 \leq u \leq R$ ,

$$0 \leq \gamma u + \frac{\lambda}{M}u - \frac{b_2}{m}u^3 \leq \gamma u + \frac{\lambda u - \beta(t)u^3}{a(v^2)} \leq \gamma u + \frac{\lambda}{m}u - \frac{b_1}{M}u^3 \quad (4.11)$$

with  $\gamma u + \frac{\lambda u}{M} - \frac{b_2}{m}u^3$  and  $\gamma u + \frac{\lambda u}{m} - \frac{b_1}{M}u^3$  being increasing functions in the variable  $u$  in the interval  $[-R, R]$ .

Now let us compare solutions of (4.2), (4.8) and (4.9). To that end, we define

$$g_1(t, u)(x) = \frac{\lambda u(x) - \beta(s + \int_s^t a(\|u_x(\cdot, \theta)\|^2)^{-1} d\theta) u^3(x)}{a(\|u_x\|^2)}$$

$$h_1(t, u)(x) = f_1(t, u)(x) = \frac{\lambda}{m} u(x) - \frac{b_1}{M} u^3(x)$$
(4.12)

$$f_2(t, u)(x) = \frac{\lambda u(x) - \beta(s + \int_s^t a(\|u_x(\cdot, \theta)\|^2)^{-1} d\theta) u^3(x)}{a(\|u_x\|^2)}$$

$$g_2(t, u)(x) = h_2(t, u)(x) = \frac{\lambda}{M} u(x) - \frac{b_2}{m} u^3(x)$$

Noticing that  $H_0^1(0, \pi)$  is embedded in  $L^\infty(0, \pi)$  and using (4.11), Theorem 2.3.20, item iii) can be applied twice to obtain the result of Theorem 4.3.2.  $\square$

**Lemma 4.3.3.** The process  $\{U(t, s) : t \geq s\}$  is strongly pullback bounded dissipative.

*Proof.* Consider  $\tau \in \mathbb{R}$  and a bounded set  $B \subset H_0^1(0, \pi)$ . We want to show that, for all  $t \leq \tau$ ,  $\lim_{s \rightarrow -\infty} \sup_{x \in B} (S(t, s)x, B(\tau)) = 0$ . Even more, it can be proven that there exists a bounded set of  $L^\infty(0, \pi)$  that pullback absorbs bounded sets of  $\{S(t, s) : t \geq s\}$ .

By Theorem 4.3.2, it follows that  $\{S(t, s) : t \geq s\}$  is bounded from below and above for the semigroups  $\{T_2(t) : t \geq 0\}$  and  $\{T_1(t) : t \geq 0\}$ , respectively. Then, for each  $u_0 \in B$ , it follows that

$$T_2(t-s)u_0 \leq U(t, s)u_0 \leq T_1(t-s)u_0.$$

As  $s \rightarrow -\infty$ ,  $t-s \rightarrow +\infty$ . Now, using that  $\{T_i(t) : t \geq 0\}$ ,  $i = 1, 2$ , admit a pullback absorbing set, it follows that we can find a  $R > 0$  (independent of  $B$ ) such that, as  $s \rightarrow -\infty$ ,

$$\|S(t, s)u_0\|_{L^\infty} \leq R, \text{ for } |s| \text{ sufficiently large.}$$

This shows that  $\{S(t, s) : t \geq s\}$  is pullback bounded dissipative in  $L^\infty(0, \pi)$ . Finally, using that  $\|\cdot\|_{H_0^1(0, \pi)} \leq \pi \|\cdot\|_{L^\infty}$ , it is clear that  $\{S(t, s) : t \geq s\}$  is also pullback bounded dissipative in  $H_0^1(0, \pi)$ .  $\square$

## 4.4 Non-autonomous equilibria

We will use the comparison result of Theorem 4.3.2 to construct the non-autonomous equilibria of (4.1).

Now, note that, by Theorem 3.1.1, if  $\lambda > M$ , we can find a positive equilibrium  $\phi_{1, b_1}^+$  of (4.8) and a positive equilibrium  $\phi_{1, b_2}^+$  of (4.9). Using Theorem 4.3.2 and the fact that  $\{T_1(t) : t \geq 0\}$  is gradient, we have

$$\phi_{1, b_2}^+ = T_2(t)\phi_{1, b_2}^+ \leq T_1(t)\phi_{1, b_2}^+ \xrightarrow{t \rightarrow +\infty} \psi,$$

for some positive equilibrium  $\psi$  of (4.8). By the uniqueness of the positive equilibrium of (4.8), we conclude that  $\psi = \phi_{1,b_1}^+$  and, consequently,  $\phi_{1,b_2}^+ \leq \phi_{1,b_1}^+$ . Define the set

$$X_1^+ = \left\{ u \in H_0^1(0, \pi) : \phi_{1,b_2}^+(x) \leq u(x) \leq \phi_{1,b_1}^+(x), u(x) = u(\pi - x) \text{ in } (0, \pi) \right\}.$$

Recall that a “positive solution” is a global solution  $\xi$  such that  $\xi(t) \in \mathcal{C}$  for all  $t \in \mathbb{R}$ . If there exists a  $\phi \in \mathcal{C} \cap \{\psi \in C^1(0, \pi) : \psi'(0) \cdot \psi'(\pi) < 0\}$  and  $t_0 \in \mathbb{R}$  such that  $\phi \leq \xi(t)$  for all  $t \leq t_0$  (for all  $t \geq t_0$ ) then  $\xi$  will be called non-degenerate as  $t \rightarrow -\infty$  (as  $t \rightarrow +\infty$ ).

Note that, a positive global solution  $\xi$  of  $\{U(t, s) : t \geq s\}$  which is non-degenerate as  $t \rightarrow \pm\infty$  is non-autonomous equilibrium (see Definition 2.3.21).

To construct a positive non-autonomous equilibrium, we will prove that  $X_1^+$  is positively invariant, which means  $U(t, s)X_1^+ \subset X_1^+$ , for all  $(t, s) \in \mathcal{P}$ . Given  $u_0 \in X_1^+$ , for  $x \in (0, \pi)$  we have

$$\phi_{1,b_2}^+(x) \leq T_2(t-s)u_0 \leq U(t, s)u_0 \leq T_1(t-s)u_0 \leq \phi_{1,b_1}^+(x),$$

where we used the comparison result of Theorem 4.3.2 and that  $T_i(t-s)\phi_{1,b_i}^+ = \phi_{1,b_i}^+$ , for all  $(t, s) \in \mathcal{P}$ ,  $i = 1, 2$ .

Since  $u_0(x) = u_0(\pi - x)$  for  $x \in (0, \pi)$ , if  $u(t, s, u_0)(x) := U(t, s)u_0(x)$ , then both maps  $(s, +\infty) \ni t \mapsto u(t, s, u_0)(\cdot)$  and  $(s, +\infty) \ni t \mapsto u(t, s, u_0)(\pi - \cdot) \in H_0^1(0, \pi)$  are solutions of (4.2) with  $u(s, s, u_0)(\cdot) = u_0(\cdot) = u_0(\pi - \cdot) = u(s, s, u_0)(\pi - \cdot)$ . By uniqueness of solutions, we conclude that  $u(t, s, u_0)(x) = u(t, s, u_0)(\pi - x)$ , for all  $x \in (0, \pi)$ .

**Theorem 4.4.1.** Suppose  $\lambda > M$ . Then the process  $\{U(t, s) : (t, s) \in \mathcal{P}\}$  restricted to  $X_1^+$  admits a pullback attractor. In particular, there exists a non-autonomous equilibrium in  $\mathcal{C}$ .

*Proof.* The positive invariance follows from the reasoning that preceded the theorem. The fact that  $\{U(t, s) : (t, s) \in \mathcal{P}\}$  has a pullback attractor in  $H_0^1(0, \pi)$  ensures that it also has a pullback attractor when restricted to  $X_1^+$ .

Now, any global solution in the pullback attractor of  $\{U(t, s) : (t, s) \in \mathcal{P}\}$  restricted to  $X_1^+$  is a non-autonomous equilibrium.

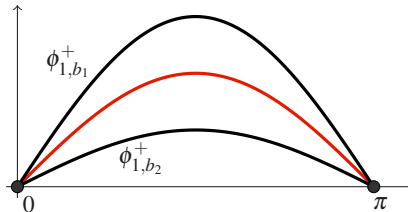

Figure 3 – Representation of the set  $X_1^+$

□

**Theorem 4.4.2.** Consider  $\lambda > MN^2$ , for some  $N \in \mathbb{N}$ . Then, for  $j = 1, \dots, N$ , the process  $\{U(t, s) : (t, s) \in \mathcal{P}\}$  restricted to  $X_j^+$  admits a pullback attractor.

In particular, for each  $j = 1, \dots, N$ , there exists a non-autonomous equilibrium  $\xi_j^+$  that has  $j + 1$  zeros in  $[0, \pi]$ .

*Proof.* By the previous theorem, since  $\lambda > M$ , it follows the existence of  $\xi_1^+$ . Now, we want to construct positively invariant regions (far from zero a.e. in  $(0, \pi)$ ).

From Theorem 3.1.1, there is an equilibrium  $\phi_{j,b_i}^+$  with  $j + 1$  zeros in  $[0, \pi]$ ,  $1 \leq j \leq N$ , for the semigroup  $\{T_i(t) : t \geq 0\}$ ,  $i = 1, 2$ .

Now, if  $1 < j \leq N$ , we consider the set  $X_j^+ = Y_j^+ \cap Z_j$ , where

$$Y_j^+ = \left\{ u \in H_0^1(0, \pi) : \min \left( \phi_{j,b_1}^+(x), \phi_{j,b_2}^+(x) \right) \leq u(x) \leq \max \left( \phi_{j,b_1}^+(x), \phi_{j,b_2}^+(x) \right), 0 \leq x \leq \pi \right\}$$

and

$$Z_j = \left\{ u \in H_0^1(0, \pi) : u(x) = u \left( \frac{\pi}{j} - x \right), 0 < x < \frac{\pi}{j}, \text{ and } u(x) = -u \left( x - \frac{\pi}{j} \right), x > \frac{\pi}{j} \right\}.$$

Let us prove that these sets are positively invariant.

We will start with  $j = 2$ .

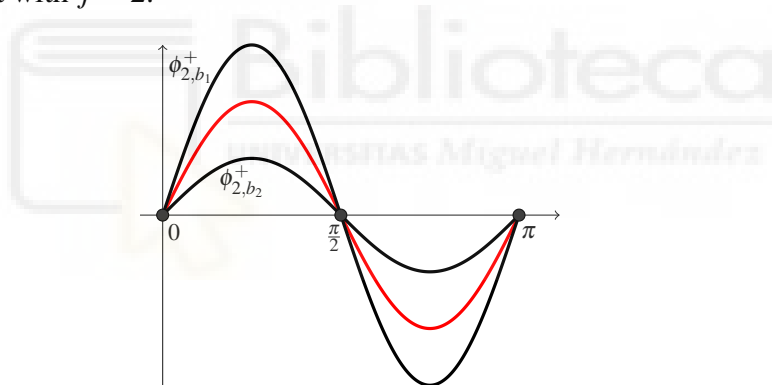

Figure 4 – A representation of the region  $X_2^+$

Consider  $u_0 \in X_2^+$  then we know  $u_0 \in Z_2$  which means that  $u_0(x) = -u_0(\pi - x)$ , for  $x \in [0, \pi]$ . And by the uniqueness of solution, we have  $u(t, s, u_0)(x) = -u(t, s, u_0)(\pi - x)$ , for all  $x \in [0, \pi]$  and  $t \geq s$ . With this we proved that  $u \in Z_2$ . In particular,  $u(t, s, u_0)(\frac{\pi}{2}) = 0$  for  $t \geq s$ .

Now we can use comparison restricted to the subintervals  $[0, \frac{\pi}{2}]$  and  $[\frac{\pi}{2}, \pi]$ :

$$\begin{cases} 0 \leq T_2(t-s)u_0 \leq U(t,s)u_0 \leq T_1(t,s)u_0 & \text{in } [0, \frac{\pi}{2}] \\ T_1(t-s)u_0 \leq U(t,s)u_0 \leq T_2(t,s)u_0 \leq 0 & \text{in } [\frac{\pi}{2}, \pi]. \end{cases}$$

Since  $\phi_{2,b_i}^+$  is an equilibrium of  $\{T_i(t) : t \geq 0\}$ ,  $i = 1, 2$  and  $0 \leq \phi_{2,b_2}^+ \leq u_0 \leq \phi_{2,b_1}^+$  in  $[0, \frac{\pi}{2}]$  and  $\phi_{2,b_1}^+ \leq u_0 \leq \phi_{2,b_2}^+ \leq 0$  in  $[\frac{\pi}{2}, \pi]$ , we can write

$$\begin{cases} 0 \leq \phi_{2,b_2}^+ \leq U(t,s)u_0 \leq \phi_{2,b_1}^+ & \text{in } [0, \frac{\pi}{2}] \\ \phi_{2,b_1}^+ \leq U(t,s)u_0 \leq \phi_{2,b_2}^+ \leq 0 & \text{in } [\frac{\pi}{2}, \pi]. \end{cases}$$



Therefore,  $X_2^+$  is positively invariant.

Before proving the case  $X_3^+$ , we will prove the positive invariance for  $X_4^+$ . Just observe that if  $u_0 \in X_4^+$  then  $u_0(x) = -u_0(\pi - x)$ , for all  $x \in (0, \pi)$  and, in particular,  $u(t, s, \frac{\pi}{2}) = 0$ . Now, we can analyze the following problem

$$\begin{cases} u_t = u_{xx} + \frac{\lambda u - \beta(s + \int_s^t \frac{1}{a(2\|u_x\|^2)} d\theta)u^3}{a(2\|u_x\|^2)}, & x \in (0, \frac{\pi}{2}), t > s \\ u(0, t) = u(\frac{\pi}{2}, t) = 0, & t \geq s \\ u(\cdot, s) = u_0(\cdot) \in H_0^1(0, \frac{\pi}{2}) \end{cases} \quad (4.13)$$

where  $\|u_x\|^2 = \int_0^{\frac{\pi}{2}} u_x^2(s) ds$ . Moreover, using the uniqueness of solution for (4.13), we conclude that

$$u(t, s, u_0)(x) = -u(t, s, u_0)(\frac{\pi}{2} - x), \quad \text{for } x \in [0, \frac{\pi}{2}]$$

and

$$u(t, s, u_0)(x) = -u(t, s, u_0)(\pi - x) \quad \text{for } x \in [0, \pi].$$

In particular,  $u(t, s, u_0, \frac{\pi}{4}) = 0$  for all  $t \geq s$  and  $u(t, s, u_0, \frac{3\pi}{4}) = -u(t, s, u_0, \frac{\pi}{4}) = 0$ .

With this, we can prove that  $u$  lies in  $Z_4$ . Now, we can use comparison to prove that  $X_4^+$  is positively invariant.

To prove the invariance of  $X_3^+$ , we define the following set

$$W_4^+ = \{u_0 \in H_0^1(0, \frac{4\pi}{3}) : u_0(x) = -u_0(\frac{4\pi}{3} - x) \text{ in } [0, \frac{4\pi}{3}] \text{ and } u_0|_{[0, \pi]} \in X_3^+\}$$

and consider the problem (4.2) in the interval  $[0, \frac{4\pi}{3}]$  and with  $a(\cdot) = a(\frac{3}{4}\cdot)$ .

We have that  $u(t, s, u_0, \frac{2\pi}{3}) = 0$  and we can use the same idea as in  $X_4^+$  to prove that  $u(t, s, u_0, \frac{\pi}{3}) = 0$ . The comparison in  $[0, \pi]$  follows similarly to the previous cases.

Therefore  $X_3^+$  is invariant under the action of  $\{U(t, s) : t \geq s\}$ , since it is a restriction of  $W_4^+$  to the interval  $[0, \pi]$ .

For the other cases,  $u_0 \in X_j^+$ , just observe that the invariance of  $Z_j$  can be obtained using the reasoning applied in the previous cases and then we conclude that  $u(t, s, u_0)(\frac{k\pi}{j}) = 0$ ,  $k = 0, \dots, j$ , for all  $t \geq s$ .

Now, for all  $(t, s) \in \mathcal{P}$ , we have the following comparison:

$$0 \leq (T_2(t-s)u_0)(x) \leq (U(t, s)u_0)(x) \leq (T_1(t-s)u_0)(x), \quad x \in [0, \frac{\pi}{j}]$$

and  $(U(t, s)u_0)(x) = -(U(t, s)u_0)(x - \frac{\pi}{j})$  and  $(T_i(t-s)u_0)(x) = -(T_i(t-s)u_0)(x - \frac{\pi}{j})$ ,  $x > \frac{\pi}{j}$ ,  $i = 1, 2$ .

With this, we conclude that  $U(t, s)u_0 \in X_j^+$  for all  $(t, s) \in \mathcal{P}$ . Therefore,  $X_j^+$  is positively invariant under the action of  $\{U(t, s) : (t, s) \in \mathcal{P}\}$ .

□

**Remark 4.4.3.** Note that if  $\lambda > 2N^2M$ , for each  $1 \leq j \leq N$ , there exists an equilibrium  $\phi_{j,b_i}^-$  of  $\{T_i(t) : t \geq 0\}$ ,  $i = 1, 2$ , with  $j + 1$  zeros in  $[0, \pi]$ . Then, we can define the set  $X_j^- = Y_j^- \cap Z_j$ , where

$$Y_j^- = \left\{ u \in H_0^1(0, \pi) : \min \left( \phi_{j,b_1}^-(x), \phi_{j,b_2}^-(x) \right) \leq u(x) \leq \max \left( \phi_{j,b_1}^-(x), \phi_{j,b_2}^-(x) \right) \right\}.$$

We can also prove that  $U(t, s)X_j^- \subset X_j^-$ , for all  $(t, s) \in \mathcal{P}$ .

Observe that the whole construction was carried out for solutions of (4.2). Recall that the change of variables only affects  $t$ , hence we have also constructed a set of bounded non-autonomous equilibria of (4.1). We can summarize the result in the following

**Theorem 4.4.4.** Suppose that  $\lambda > 2N^2M$ , for  $0 < N \in \mathbb{N}$ . The problem (4.1) has at least  $2N$  non-autonomous equilibria.

## 4.5 Some remarks and open problems for further investigations

In this chapter, we have treated the quasilinear parabolic problem (4.1). We would like to mention that there is a developed theory of quasilinear problems (see for instance (LUNARDI, 1995)). In our case, it can be shown that we need to ask more assumptions on  $a(\cdot)$  to apply the usual quasilinear theory.

Semilinear problems are very well-known and then we were able to provide the results on existence of global solutions and the pullback attractor for the semilinear problem (4.2), which are transferable to (4.1). Although the relation between (4.1) and (4.2) is dependent of any solution (not a uniform change of variable), we do not have loss or gain of information since  $a(\cdot)$  is bounded above and below for positive constants.

Now, if  $a(\cdot) \equiv 1$ , (4.1) is in fact (3.11) and we are able to obtain a very sharp comparison result. That means, we are able to determine the parameters for which bifurcations of the non-autonomous equilibria happen at 0.

The comparison result we have obtained for (4.1) can be improved. For instance, we have compared (4.1) with Chafee-Infante problems. For that reason, we were not able to determine the parameters of bifurcation at 0. We have only provided values for those we can guarantee the existence of the non-autonomous equilibria. Although it is yet to be proved, we would guess that the bifurcation at zero happens for the parameters  $a(0)N^2$ , for  $N \in \mathbb{N}$ .

Another difference between the results of (4.1) and (3.11) relies on the fact that we are not able to determine the exact number of non-autonomous equilibria. To be more precise, if  $\lambda \in (MN^2, M(N+1)^2)$ , for  $N \in \mathbb{N}$ , there are at least  $2N$  non-autonomous equilibria for (4.1).

## THE AUTONOMOUS NONLOCAL PARABOLIC PROBLEM

---

In this chapter, we will explore an autonomous nonlocal quasilinear problem. First, we will show that the problem admits a sequence of bifurcations from zero under suitable conditions. We will also show results on stability and hyperbolicity of the equilibria. Later, we will apply topological techniques to show the connection between equilibria inside the attractor. This chapter is a summarized collection of results, made with collaborators in the works (LI *et al.*, 2020; CARVALHO; MOREIRA, 2021; MOREIRA; VALERO, 2022b; ARRIETA *et al.*, 2022).

Consider now the autonomous non-local problem

$$\begin{cases} u_t = a(\|u_x\|^2)u_{xx} + \lambda f(u), & x \in (0, \pi), t > 0, \\ u(0, t) = u(\pi, t) = 0, & t \geq 0, \\ u(0) = u_0 \in H_0^1(0, \pi). \end{cases} \quad (5.1)$$

with  $f$  satisfying (3.2). We will assume that  $a \in C^1(\mathbb{R}^+)$ , with  $a(\mathbb{R}^+) \subset [m, M]$  for  $0 < m < M$ . We will see that (5.1) is globally well-posed. We will show that this problem admits generates a gradient semigroup with a Lyapunov function  $V : H_0^1(0, \pi) \rightarrow \mathbb{R}$  given by

$$V(u) = \frac{1}{2} \int_0^{\|u_x\|^2} a(s) ds - \int_0^\pi \lambda F(u(x)) dx, \quad (5.2)$$

where  $F(s) = \int_0^s f(r) dr$ .

The problem (5.1) was based on the Chafee-Infante problem (see Chapter 3). One can be misled to think the additional nonlocal term would not affect much the dynamics of the problem, since the function  $a$  has a positive lower and upper bound. In this chapter, we will show that, in fact, surprising and unexpected behavior may happen according to our choice of  $a$ .

With the additional assumption of  $a$  being increasing, we will show that (5.1) and (3.1) have similar dynamics, in terms of the number of equilibria and their connections.

## 5.1 Existence of the attractor

First we will show the following

**Proposition 5.1.1.** The map  $V : H_0^1(0, \pi) \rightarrow \mathbb{R}$  given by  $V(u) = \frac{1}{2} \int_0^\pi \|u_x\|^2 a(s) ds - \int_0^\pi \lambda F(u(x)) dx$ , for  $u \in H_0^1(0, \pi)$ , is a Lyapunov function for (5.1).

*Proof.* First, it is clear that  $V$  is continuous, since it is defined in terms of continuous functions. Consider  $u, h \in H_0^1(0, \pi)$ . We have

$$\begin{aligned} \frac{V(u+h) - V(u)}{\|h_x\|} &= \int_0^\pi \frac{\|u_x+h_x\|^2 - \|u_x\|^2}{\|h_x\|} a(s) ds - \int_0^\pi \lambda [F(u(x)+h(x)) - F(u(x))] dx \\ &\leq \int_0^\pi \|h_x\| (\|h_x\| + 2\|u_x\|) a(s) ds + \int_0^\pi \lambda [f(u(x) + \theta(x)h(x)) - f(u(x))] u(x) dx, \end{aligned}$$

for  $\theta(x) \in (0, 1)$ ,  $x \in [0, \pi]$  where we have used the Hölder's inequality and the Mean Value Theorem. As  $\|h_x\| \rightarrow 0^+$ , we can see that  $V(u+h) - V(u) \rightarrow 0$ . Thus,  $V$  is continuous.

Suppose that  $u : [0, T) \rightarrow H_0^1(0, \pi)$ ,  $T > 0$  is a solution of (5.1). We want to show that  $V$  is decreasing along solutions  $u(t)$  as  $t$  increases. To see that, we will calculate  $\dot{V}(u)$ .

$$\begin{aligned} \dot{V}(u) &= \frac{a(\|u_x\|^2)}{2} \frac{d}{dt} \|u_x\|^2 - \int_0^\pi \lambda f(u(x)) u_t(x) dx \\ &= -a(\|u_x\|^2) \int_0^\pi u_{xx}(s) u_t(s) ds - \int_0^\pi \lambda f(u(x)) u_t(x) dx \\ &= - \int_0^\pi [a(\|u_x\|^2) u_{xx} + \lambda f(u)] u_t dx = -\|u_t\|^2 \leq 0. \end{aligned}$$

Thus,  $V$  is decreasing along solutions of (5.1). Now, if  $V$  is constant on the solution  $u$ , we have  $0 = \dot{V}(u) = -\|u_t\|^2$ , for all  $t \in \mathbb{R}^+$ . Consequently,  $u_t = 0$ , for all  $t \geq 0$ , and  $u \in \mathcal{E}$  (the set of equilibria of (5.1)).

Therefore,  $V$  is a Lyapunov function for (5.1). □

The existence of the semigroup follows by using the same arguments applied to the non-autonomous case in Chapter 4. That is, we consider the semilinear problem

$$\begin{cases} u_t = u_{xx} + \frac{\lambda f(u)}{a(\|u_x\|^2)}, & t > 0, \\ u(t, 0) = u(t, \pi) = 0, & t \geq 0, \\ u(\cdot) = u_0 \in H_0^1(0, \pi) \end{cases} \quad (5.3)$$

with  $a$  and  $f$  with the same conditions required by (5.1). We show the global well-posedness of this problem together with the continuity related to the initial data for the problem above. We use this information to prove the same properties for (5.1). In particular, we have that both problems share the same equilibria and, moreover, the global attractor.

In (CABALLERO *et al.*, 2021), the authors have explored the problem (5.1) for  $f \in C(\mathbb{R})$ . They applied Galerkin approximations in order to do so. In that case, the problem generates a multivalued semiflow. Additionally, they have shown the existence of the attractor and answered some questions about its structure.

**Theorem 5.1.2.** There is a semigroup associated to (5.1) that admits a global attractor  $\mathcal{A}$ .

*Proof.* Here, we will apply an argument to show the existence of a global solution by using its Lyapunov function, which is given by (5.2). The existence of a local solution can be made using the same arguments applied to (4.1) in Chapter 5.

Recall that, for each  $\varepsilon > 0$ , there is a constant  $M_\varepsilon > 0$  such that  $f(r)r \leq \varepsilon r^2 + M_\varepsilon$ , for all  $r \in \mathbb{R}$ . It also can be shown that, for each  $\varepsilon > 0$ , there is a  $N_\varepsilon > 0$  such that  $F(r) \leq \varepsilon r^2 + N_\varepsilon$ ,  $r \in \mathbb{R}$ .

Consequently, for each solution of (5.1), we have

$$\begin{aligned} \|u_x\|^2 &\leq \frac{2}{m}V(u) + \frac{2\lambda}{m} \int_0^\pi F(u)ds \leq \frac{2}{m}V(u) + \frac{2\lambda}{m} \int_0^\pi (\varepsilon u^2(s) + N_\varepsilon)ds \\ &\leq \frac{2}{m}V(u) + \frac{2\lambda\varepsilon}{m} \|u\|^2 + \frac{2N_\varepsilon\pi}{m}. \end{aligned}$$

Hence, using Poincaré's inequality and that  $V$  is a Lyapunov function, we can choose  $\varepsilon > 0$  sufficiently small such that, for  $t \geq 0$ , as long as exists, the solution satisfies

$$\|u_x(t)\|^2 \leq \frac{4}{m}[V(u(0)) + N_\varepsilon\pi].$$

Therefore, the solution must exist for all  $t \geq 0$ .

The continuity with respect to initial data also follows analogously to the result for (4.1). Moreover, the existence of a global attractor follows as consequence of the existence of a pullback attractor for (4.1). In fact, we can take  $\beta(\cdot) \equiv \text{constant}$  in (4.1) and the results follow for  $f(u) = \lambda u - bu^3$ ,  $b > 0$ , as well for  $f$  satisfying our conditions.  $\square$

## 5.2 Equilibria of the autonomous problem

In this section we construct the equilibria for (5.1). In order to do that, we will construct auxiliary functions. The construction we present here was developed with collaborators in (ARRIETA *et al.*, 2022).

Let us now define an auxiliary function which will allow us to see the equilibria of (3.1) as equilibria of a nonlocal problem.

Let  $i \in \{+, -\}$  and  $j \in \mathbb{N}$ . For  $\lambda > j^2$ , denote by  $\phi_{j,\lambda}^i$  the solution of

$$\begin{cases} u_{xx} + \lambda f(u) = 0 \\ u(0) = u(\pi) = 0, \end{cases} \quad (5.4)$$

that has  $j + 1$  zeros in  $[0, \pi]$  and with  $i(\phi_{j,\lambda}^i)'(0) > 0$ . As we have seen in Theorem 3.1.5, for each positive integer  $j$  and  $i \in \{+, -\}$ , the function  $(j^2, \infty) \ni \lambda \mapsto \phi_{j,\lambda}^i \in H_0^1(0, \pi)$  is continuously differentiable and  $(j^2, \infty) \ni \lambda \mapsto \int_0^\pi ((\phi_{j,\lambda}^i)_x(s))^2 ds \in (0, \infty)$  is strictly increasing and continuously differentiable, with  $\|(\phi_{j,\lambda}^i)_x\| \rightarrow +\infty$  as  $\lambda \rightarrow +\infty$ .

**Definition 5.2.1.** For each positive integer  $j$  and  $i \in \{+, -\}$  and  $r \geq 0$ , let  $\lambda_{j,r}^i \in [j^2, \infty)$  be the unique  $\lambda$  such that  $\int_0^\pi ((\phi_{j,\lambda}^i)_x)^2 = r$ . Let  $c_j^i : [0, \infty) \rightarrow [\frac{1}{j^2}, \infty)$  be the function defined by  $c_j^i(r) = \frac{1}{\lambda_{j,r}^i}$ , for each  $r \geq 0$ .

It is easy to see that  $c_j^i(\cdot)$  is strictly decreasing and continuously differentiable with  $\lim_{r \rightarrow 0} c_j^i(r) = \frac{1}{j^2}$ .

Now, consider the following ‘nonlocal’ problem

$$\begin{cases} c_j^i(\|u_x\|^2)u_{xx} + f(u) = 0 \\ u(0) = u(\pi) = 0. \end{cases} \quad (5.5)$$

We have the following result:

**Lemma 5.2.2.** Let  $i \in \{+, -\}$  and  $j \in \mathbb{N}$ . The family  $\{\phi_{j,\lambda}^i : \lambda \in [j^2, +\infty)\}$  is a set of solutions of (5.5).

*Proof.* This follows by definition of  $c_j^i$ . In fact, for each  $\lambda \in [j^2, +\infty)$ , we have  $c_j^i(\|(\phi_{j,\lambda}^i)_x\|^2) = \frac{1}{\lambda}$  and  $c_j^i(\|(\phi_{j,\lambda}^i)_x\|^2)(\phi_{j,\lambda}^i)_{xx} + f((\phi_{j,\lambda}^i)_x) = 0$ .  $\square$

Let us study the sequence of bifurcation for the nonlocal problem (5.1). In order to do that, consider, for any  $r \in [0, +\infty)$ , the problem

$$\begin{cases} u_t = a(r)u_{xx} + \lambda f(u), & x \in (0, \pi), t > 0, \\ u(0, t) = u(\pi, t) = 0, & t \geq 0, \\ u(\cdot, 0) = u_0(\cdot) \in H_0^1(0, \pi). \end{cases} \quad (5.6)$$

Now, we present the result of the existence of equilibria for (5.1).

**Theorem 5.2.3.** For each positive integer  $j$  and  $i \in \{+, -\}$ , consider  $c_j^i(\cdot)$  the map defined above. For  $v > 0$  and  $r > 0$ , (5.1) with  $\lambda = v$  has an equilibrium  $\psi$ , with  $j + 1$  zeros in the interval  $[0, \pi]$  such that  $i(\psi)_x(0) > 0$  and  $\|\psi_x\|^2 = r$  if and only if  $vc_j^i(r) = a(r)$ .

*Proof.* If  $\psi$  is an equilibrium of (5.1), with  $j + 1$  zeros in the interval  $[0, \pi]$  such that  $i\psi_x(0) > 0$  and  $\|\psi_x\|^2 = r$ , then  $\psi = \phi_{j,\lambda_{j,r}^i}^i$  and  $vc_j^i(r) = a(r)$ . On the other hand, since  $\phi_{j,\lambda_{j,r}^i}^i$  is a solution of (5.5) with  $\|(\phi_{j,\lambda_{j,r}^i}^i)_x\|^2 = r$  and since  $vc_j^i(r) = a(r)$ ,  $\psi = \phi_{j,\lambda_{j,r}^i}^i$  is an equilibrium of (5.1).

Now, suppose that  $vc_j^i(r) = a(r)$ . Since  $c_j^i$  is strictly decreasing and  $c_j^i(0) = \frac{1}{j^2}$ , we have that  $\frac{v}{a(r)} > j^2$ . Consequently, there exists an equilibrium  $\phi$  of (5.6), for  $\lambda = v$ , with  $i\phi'(0) > 0$  and that has  $j + 1$  zeros in  $[0, \pi]$ . In other words,  $\phi$  satisfies

$$\begin{cases} a(r)\phi_{xx} + vf(\phi) = 0 \\ \phi(0) = \phi(\pi) = 0. \end{cases}$$

Hence, if  $c_j^i(r) = \frac{1}{\lambda_r}$ , applying the hypothesis, we conclude that

$$\phi_{xx} + \lambda_r f(\phi) = 0,$$

which by the definition of  $c_j^i$  implies  $\phi = \phi_{j, \lambda_r}^i$  and  $\|\phi_x\|^2 = r$ . Therefore,  $\phi$  is an equilibrium of (5.1).  $\square$

**Corollary 5.2.4.** For each positive integer  $k$  and  $i \in \{+, -\}$ , if  $v > k^2 a(0)$  there are at least  $2k + 1$  equilibria of the non-local problem (5.1), with  $\lambda = v$ .

Moreover, for  $\lambda \in (a(0)k^2, a(0)(k+1)^2]$ ,  $k \in \mathbb{N}$ , if  $a$  is non-decreasing, then (5.1) has exactly  $2k + 1$  equilibria.

*Proof.* That is an immediate consequence of the fact that the functions  $c_j^i : [0, \infty) \rightarrow [\frac{1}{j^2}, \infty)$  are continuous,  $vc_j^i(0) = \frac{v}{j^2} > a(0)$ ,  $c_j^i(r) \xrightarrow{r \rightarrow \infty} 0$ ,  $1 \leq j \leq k$ , and  $a : [0, \infty) \rightarrow [m, M]$  is continuous.

In particular, if  $a$  is non-decreasing we have exactly  $2k + 1$  equilibria of (5.1).  $\square$

**Remark 5.2.5.** One can make different approaches to construct the equilibria of (5.1). For instance, in (LI *et al.*, 2020) the authors construct a positive (and negative) equilibrium by using variational methods. The other equilibria are constructed using the symmetries of the problem, assuming that  $a$  is increasing and  $f$  odd. In (CABALLERO *et al.*, 2021), the authors construct the equilibria for  $f$  not necessarily odd. In (CARVALHO; MOREIRA, 2021), the authors proved the following result:

**Theorem 5.2.6.** Assume that  $a$  is increasing and that  $f$  is odd. If  $a(0)N^2 < v \leq a(0)(N+1)^2$ , then there are  $2N + 1$  equilibria of the equation (5.3);  $\{0\} \cup \{\phi_j^\pm : j = 1, \dots, N\}$ , where  $\phi_j^+$  and  $\phi_j^-$  have  $j + 1$  zeros in  $[0, \pi]$  and  $\phi_j^-(x) = -\phi_j^+(x)$  for all  $x \in [0, \pi]$  and  $\phi_j^+(x) > 0$  for all  $x \in (0, \frac{\pi}{j})$ . The sequence of bifurcation given above satisfies:

Stability: If  $v \leq a(0)$ , 0 is the only equilibrium of (3.1) and it is stable. If  $v > a(0)$ , the positive equilibrium  $\phi_1^+$  and the negative equilibrium  $\phi_1^-$  are stable and any other equilibrium is unstable.

Hyperbolicity: For all  $v > 0$ , the equilibria are hyperbolic with the exception of 0 in the cases  $v = a(0)N^2$ , for  $N \in \mathbb{N}^*$ .

The proof of the above theorem in (CARVALHO; MOREIRA, 2021) strongly uses the symmetries of the problems. Such proof is long and it is very interesting how the symmetries were used. Although we think such proof is worth seeing, here we will present a more general and simple proof of the hyperbolicity of equilibria of (5.1).

### 5.3 Hyperbolicity of the equilibria of (5.3)

As we have mentioned before, problems (5.1) and (5.3) have exactly the same equilibria. As in (CARVALHO; MOREIRA, 2021), the spectral analysis of the self-adjoint operator associated to the linearization of (5.3) around an equilibria  $\psi$  will determine its stability and if it is hyperbolic.

**Proposition 5.3.1.** The linearization of (5.3) around an equilibrium  $\psi$  is given by the equation

$$v_t = Lv$$

where  $D(L) = H^2(0, \pi) \cap H_0^1(0, \pi)$  and

$$Lv = v'' + \frac{\nu f'(\psi)}{a(\|\psi_x\|^2)}v - \frac{2\nu^2 a'(\|\psi_x\|^2)}{a(\|\psi_x\|^2)^3}f(\psi) \int_0^\pi f(\psi)v, \quad v \in D(L). \quad (5.7)$$

*Proof.* Consider  $h \in H^2(0, \pi) \cap H_0^1(0, \pi)$ . Then, we have the following

$$\begin{aligned} (\phi + h)'' + \nu \frac{f(\phi + h)}{a(\|(\phi + h)'\|^2)} - \phi'' - \nu \frac{f(\phi)}{a(\|\phi'\|^2)} \\ = h'' + \nu \frac{f(\phi + h) - f(\phi)}{a(\|(\phi + h)'\|^2)} + \nu f(\phi) \left( \frac{a(\|\phi'\|^2) - a(\|(\phi + h)'\|^2)}{a(\|(\phi + h)'\|^2)a(\|\phi'\|^2)} \right) \\ = Lh + r_1(h) + r_2(h) + r_3(h) \end{aligned}$$

where

$$r_1(h) = \nu \frac{f(\phi + h) - f(\phi) - f'(\phi)h}{a(\|(\phi + h)'\|^2)} + \nu f'(\phi)h \left( \frac{1}{a(\|(\phi + h)'\|^2)} - \frac{1}{a(\|\phi'\|^2)} \right)$$

and

$$r_2(h) = \frac{\nu f(\phi)}{a(\|(\phi + h)'\|^2)a(\|\phi'\|^2)} (a(\|\phi'\|^2) - a(\|(\phi + h)'\|^2) + 2a'(\phi) \langle \phi_x, h_x \rangle)$$

and

$$r_3(h) = -\frac{2\nu a'(\phi)}{a(\|(\phi + h)'\|^2)a(\|\phi'\|^2)} \langle \phi_x, h_x \rangle f(\phi) + \frac{2\nu^2 a'(\|\phi_x\|^2)}{a(\|\phi_x\|^2)^3} f(\phi) \langle f(\phi), u \rangle.$$

Now, for  $C_\phi = \sup\{f'(\phi(x)) : x \in [0, \pi]\}$ , we have

$$\|r_1(h)\| \leq \frac{\nu}{m} \|f(\phi + h) - f(\phi) - f'(\phi)h\| + \frac{C_\phi \nu \sqrt{\pi} |a(\|\phi'\|^2) - a(\|(\phi + h)'\|^2)|}{m^2} \|h\|.$$



Now, for  $D_\phi = \sup\{f(\phi(x)) : x \in [0, \pi]\}$ ,

$$\|r_2(h)\| \leq \frac{vD_\phi}{m^2} \|a(\|\phi'\|^2) - a(\|\phi+h\|^2) - 2a'(\phi) \langle \phi_x, h_x \rangle\|$$

Finally, using integration by parts and the fact that  $\phi$  is a solution of (5.1), we have

$$\begin{aligned} \|r_3(h)\| &= \left\| \frac{2v^2 a'(\phi) f(\phi) \langle f(\phi), h \rangle}{a(\|\phi_x\|^2)^2} \left[ \frac{1}{a(\|\phi_x\|^2)} - \frac{1}{a(\|\phi_x + h_x\|^2)} \right] \right\| \\ &\leq \frac{2v^2 a'(\phi) D_\phi |a(\|\phi_x + h_x\|^2) - a(\|\phi_x\|^2)|}{m^3} \|h\|. \end{aligned}$$

By the limitations above, it is clear that

$$\lim_{\|h\|_{X^1} \rightarrow 0^+} \frac{\|(\phi+h)'' + \frac{v}{a(\|\phi+h\|^2)} f(\phi+h) - \phi'' - \frac{v}{a(\|\phi\|^2)} f(\phi) - Lh\|}{\|h\|_{X^1}} = 0.$$

□

Given an equilibrium  $\psi \neq 0$  of (5.3), a positive integer  $k$  and a symbol  $i \in \{+, -\}$  such that,  $\psi$  vanishes  $k+1$  times in the interval  $[0, \pi]$  and  $i\psi_x(0) > 0$ . Let  $r = \|\psi_x\|^2$  and choose  $\lambda_{k,r}^i = (c_k^i(r))^{-1}$ . Then  $\psi = \phi_{k,\lambda_{k,r}^i}^i$  where  $\phi_{k,\lambda_{k,r}^i}^i$  is the solution of (5.4) with  $\lambda = \lambda_{k,r}^i$ . For simplicity of notation we will write  $c(\cdot)$  instead of  $c_k^i(\cdot)$ ,  $\lambda_r$  instead of  $\lambda_{k,r}^i$  and  $\phi_{\lambda_r}$  instead of  $\phi_{k,\lambda_{k,r}^i}^i$  for the remainder of this section.

**Remark 5.3.2.** Observe that, for each  $r \in \mathbb{R}^+$ , we find  $\lambda_r \in [j^2, +\infty)$  such that

- (1.)  $r = \|[\phi_{\lambda_r}]_x\|^2$ ;
- (2.)  $[\phi_{\lambda_r}]_{xx} + \frac{f(\phi_{\lambda_r})}{c(r)} = 0$ .

Let  $\psi(r) = \phi_{\lambda_r}$ ,  $r \in \mathbb{R}^+$ . Differentiating (2.) with respect to  $r$ , and representing  $\frac{d\psi(r)}{dr} = \dot{\psi}(r)$ , we find

$$\dot{\psi}_{xx}(r) + \frac{f'(\psi(r))\dot{\psi}(r)}{c(\|\psi(r)\|_x^2)} - \frac{f(\psi(r))c'(\|\psi(r)\|_x^2)}{[c(\|\psi(r)\|_x^2)]^2} \frac{d}{dr} \|\psi(r)\|_x^2 = 0.$$

Denote  $(\psi(r))_x = \psi_x(r)$ . Now, since

$$\frac{d}{dr} \|\psi_x(r)\|^2 = 2 \langle \psi_x(r), (\dot{\psi}(r))_x \rangle = -2 \langle (\psi(r))_{xx}, \dot{\psi}(r) \rangle = \frac{2}{c(\|\psi_x(r)\|^2)} \langle f(\psi(r)), \dot{\psi}(r) \rangle,$$

we may write

$$\dot{\psi}_{xx}(r) + \frac{f'(\psi(r))\dot{\psi}(r)}{c(\|\psi_x(r)\|^2)} - \frac{f(\psi(r))c'(\|\psi_x(r)\|^2)}{c(\|\psi_x(r)\|^2)^2} - \frac{2c'(\|\psi_x(r)\|^2)f(\psi(r))\langle f(\psi(r)), \dot{\psi}(r) \rangle}{c(\|\psi_x(r)\|^2)^3} = 0.$$

Now, consider  $L_c : D(L_c) \subset L^2(0, \pi) \rightarrow L^2(0, \pi)$  where  $D(L_c) = H^2(0, \pi) \cap H_0^1(0, \pi)$  and

$$L_c v = v'' + \frac{\lambda f'(\psi(r))}{c(\|\psi(r)\|_x^2)} v - \frac{2\lambda c'(\|\psi(r)\|_x^2)}{c(\|\psi(r)\|_x^2)^3} f(\psi(r)) \int_0^\pi f(\psi(r)) v, \quad v \in D(L_c).$$

Since  $\dot{\psi}(r) \in H^2(0, \pi) \cap H_0^1(0, \pi)$  and  $L_c \dot{\psi}(r) = 0$ , it follows that  $0 \in \sigma(L_c)$ .

**Theorem 5.3.3.** Consider  $\psi$  an equilibrium of (5.3), for  $\lambda = v$ , that has  $k + 1$  zeros in  $[0, \pi]$  and with  $i(\psi)'(0) > 0$ , for some  $k \in \mathbb{N}$  and  $i \in \{+, -\}$ . The equilibrium  $\psi$  of (5.3) is not hyperbolic if, and only if,  $a'(\|\psi_x\|^2) = v(c_k^i)'(\|\psi_x\|^2)$ .

*Proof.* Just for simplicity, denote  $c_k^i(\cdot)$  by  $c(\cdot)$  and  $\phi_{k,\lambda_r}^i$  by  $\phi_{\lambda_r}$

( $\Leftarrow$ ) Suppose initially that  $a'(\|\psi_x\|^2) = vc'(\|\psi_x\|^2)$ . Let  $r = \|\psi_x\|^2$ . In the notation above, we have that  $\psi = \phi_{k,\lambda_r}^i$ .

Recall that, as we have seen it above,  $w = \frac{d}{dr}\phi_{\lambda_r}$  satisfies

$$w_{xx} + \frac{f'(\phi_{\lambda_r})}{c(r)}w - \frac{2c'(r)}{c(r)^3}f(\phi_{\lambda_r}) \int_0^\pi f'(\phi_{\lambda_r})w = 0.$$

From Theorem 5.2.3,  $a(r) = vc(r)$ . Since,  $\|\psi_x\|^2 = r$ ,  $\psi = \phi_{\lambda_r}$  and  $a'(r) = vc'(r)$  we have

$$w_{xx} + \frac{vf'(\psi)}{a(\|\psi_x\|^2)}w - \frac{2v^2a'(\|\psi_x\|^2)}{a(\|\psi_x\|^2)^3}f(\psi) \int_0^\pi f'(\psi)w = 0.$$

Therefore, 0 is an eigenvalue of  $L$ , which implies that  $\psi$  is not a hyperbolic equilibrium.

( $\Rightarrow$ ) Assume that we find a  $0 \neq u \in H^2(0, \pi) \cap H_0^1(0, \pi)$  satisfying

$$u_{xx} + \frac{vf'(\psi)u}{a(\|\psi_x\|^2)}u - \frac{2v^2\alpha a'(\|\psi_x\|^2)}{a(\|\psi_x\|^2)^3}f(\psi) = 0$$

for  $\alpha = \int_0^\pi f(\psi(s))u(s)ds$ . Now, since  $a(r) = vc(r)$  and  $\phi_{\lambda_r} = \psi$ ,  $v = \frac{d}{dr}\phi_{\lambda_r}$  satisfies

$$v_{xx} + \frac{vf'(\psi)}{a(\|\psi_x\|^2)}v - \frac{2v^3\beta c'(\|\psi_x\|^2)}{a(\|\psi_x\|^2)^3}f(\psi) = 0,$$

for  $\beta = \int_0^\pi f(\psi(s))v(s)ds$ .

Consequently,  $z = \beta vc'(r)u - \alpha a'(r)v$  is the solution of

$$\begin{cases} z_{xx} + \frac{vf'(\phi_{\lambda_r})}{a(\|\phi_{\lambda_r}\|^2)}z = 0 \\ z(0) = z(\pi) = 0. \end{cases} \quad (5.8)$$

It follows from Lemma 3.1.3 that  $z \equiv 0$ . Thus  $\beta vc'(r)u - \alpha a'(r)v = 0$  and, by multiplying both sides of equality by  $f(\phi)$  and integrating from 0 to  $\pi$ , we find

$$\alpha\beta vc'(r) = \alpha\beta a'(r).$$

Clearly,  $\alpha\beta \neq 0$ . Otherwise, either  $u$  or  $v$  should be a solution of (5.8), that is, either  $u = 0$  or  $v = 0$ , which would be a contradiction.

Therefore, we conclude that  $a'(r) = vc'(r)$ .  $\square$

Now we analyze what happens to the dimension of the unstable manifolds for the equilibria of (5.3) as they bifurcate. This requires a deeper study of the spectrum of (5.7).

For  $\varepsilon \in \mathbb{R}$ , define the operator  $L_\varepsilon : H^2(0, \pi) \cap H_0^1(0, \pi) \subset L^2(0, \pi) \rightarrow L^2(0, \pi)$

$$L_\varepsilon u(x) = u'' + p(x)u + \varepsilon q(x) \int_0^\pi q(s)u(s)ds.$$

where  $p, q : [0, \pi] \rightarrow \mathbb{R}$  are continuous functions with  $q \not\equiv 0$ .

When  $\varepsilon = 0$ , the operator  $L_0 u = u'' + p(x)u$  is a Sturm-Liouville operator. Hence,  $L_0$  is a self-adjoint operator with compact resolvent and its spectrum consists of a decreasing sequence of simple eigenvalues

$$\sigma(L_0) = \{\gamma_j : j = 1, 2, 3, \dots\}$$

with,  $\gamma_j > \gamma_{j+1}$  and  $\gamma_j \rightarrow -\infty$  as  $j \rightarrow +\infty$ .

Note that, for all  $\varepsilon \in \mathbb{R}$ , we can decompose  $L_\varepsilon$  as sum of two operators

$$L_\varepsilon u = L_0 u + \varepsilon B u$$

where  $B u = q(x) \int_0^\pi q(s)u(s)ds$ , for all  $u \in H^2(0, \pi) \cap H_0^1(0, \pi)$ , is a bounded operator with rank one. It is easy to see that  $L_\varepsilon$  is also self-adjoint with compact resolvent. Then, we write  $\{\mu_j(\varepsilon) : j = 1, 2, 3, \dots\}$  to represent the eigenvalues of  $L_\varepsilon$ , ordered in such a way that, for  $j = 1, 2, 3, \dots$ , the function  $\mathbb{R} \ni \varepsilon \mapsto \mu_j(\varepsilon) \in \mathbb{R}$  satisfies  $\mu_j(0) = \gamma_j$ .

There are several works exploring spectral properties of operators such as  $L_\varepsilon$  (see, for example, (FREITAS, 1994; CATCHPOLE, 1974; DAVIDSON; DODDS, 2006; DODDS, 2008)). We will use, in an essential way, Theorems 3.4 and 4.5 of (DAVIDSON; DODDS, 2006), which will be summarized in our next theorem.

**Theorem 5.3.4.** For  $\varepsilon \in \mathbb{R}$ , let  $L_\varepsilon$  and  $\{\mu_j(\varepsilon) : j = 1, 2, 3, \dots\}$  be as above. The following holds:

- i) For all  $j = 1, 2, 3, \dots$ , the function  $\mathbb{R} \ni \varepsilon \mapsto \mu_j(\varepsilon) \in \mathbb{R}$  is non-decreasing.
- ii) If for some  $j = 1, 2, 3, \dots$  and  $\varepsilon \in \mathbb{R}$ ,  $\mu_j(\varepsilon) \notin \{\gamma_k : k = 1, 2, 3, \dots\}$ , then  $\mu_j(\varepsilon)$  is a simple eigenvalue of  $L_\varepsilon$ .

We wish to determine the Morse Index of the equilibria of (5.3) by looking carefully to the points where the graphs of the functions  $a(\cdot)$  and  $vc(\cdot)$  intercept. That is, depending on how these curves intersect we will be able to determine the Morse Index of an equilibrium. For  $k \in \mathbb{N}$ ,  $i \in \{+, -\}$ , the intersection of the graphs of  $a(\cdot)$  and  $vc_k^i(\cdot)$  necessarily gives rise to an equilibrium that changes sign  $k + 1$  times in  $[0, \pi]$  for (5.3). Hence, if that intersection happens at a value of  $r$  which is not zero and prior to an intersection at  $r = 0$ . This would give rise to saddle-node bifurcations.

This is the main result of this section:

**Theorem 5.3.5.** Suppose that  $\psi$  is an equilibrium of (5.3),  $\psi \neq 0$ . Let  $k \in \mathbb{N}$ ,  $i \in \{+, -\}$ ,  $r = \|\psi_x\|^2$  and  $\lambda_r$  be such that  $\psi = \phi_{k, \lambda_r}^i$ . Denote  $c_k^i(\cdot)$  by  $c(\cdot)$ .

We have the following:

- (i) If  $a'(\|\psi_x\|^2) > vc'(\|\psi_x\|^2)$ , then  $\psi$  is hyperbolic and its Morse index is  $k - 1$ .
- (ii) If  $a'(\|\psi_x\|^2) < vc'(\|\psi_x\|^2)$ , then  $\psi$  is hyperbolic and its Morse index is  $k$ .

*Proof.* The hyperbolicity follows from Theorem 5.3.3. Define the operator

$$L_\varepsilon v = v'' + \frac{vf'(\psi)}{a(\|\psi_x\|^2)}v + \varepsilon f(\psi) \int_0^\pi f(\psi)v, \quad (5.9)$$

$v \in D(L_\varepsilon) = H^2(0, \pi) \cap H_0^1(0, \pi)$ , for each  $\varepsilon > 0$ .

Note that,  $L_0$  is the linearization of (3.1) at  $\psi$  for the parameter  $v_0 = \frac{v}{a(\|\psi_x\|^2)}$ . The spectrum of  $L_0$  is given by an unbounded ordered sequence  $\{\lambda_j(0)\}_{j \in \mathbb{N}}$  of simple eigenvalues, that is,

$$\lambda_1(0) > \lambda_2(0) > \dots > \lambda_{k-1}(0) > \lambda_k(0) > \lambda_{k+1}(0) > \dots$$

Also, for  $\tilde{\varepsilon} = -\frac{2c'(\|\psi_x\|^2)}{c(\|\psi_x\|^2)^3} = -\frac{2v^3c'(\|\psi_x\|^2)}{a(\|\psi_x\|^2)^3}$ , we have  $0 \in \sigma(L_{\tilde{\varepsilon}})$ . Using the same reasoning applied in the proof of the first part of Theorem 5.3.3, we can show that if  $0 \in \sigma(L_\varepsilon)$ , then  $\varepsilon = \tilde{\varepsilon}$ . By Theorem 5.3.4, part ii), 0 is a simple eigenvalue of  $L_{\tilde{\varepsilon}}$ .

Using Theorem 5.3.4, part i), we deduce that  $\lambda_j(\varepsilon) > 0$ ,  $j = 1, \dots, k-1$ , for all  $\varepsilon \geq 0$ . Since  $0 \in \sigma(L_\varepsilon)$  if and only if  $\varepsilon = \tilde{\varepsilon} > 0$ , we must have  $\lambda_j(\varepsilon) > 0$ ,  $j = 1, \dots, k-1$ , for all  $\varepsilon < 0$ .

By definition,  $\lambda_k(0) > \lambda_j(0)$ , for all  $j > k$ . Since  $\lambda_k(\cdot)$  is increasing and  $L_0$  does not have an eigenvalue in the interval  $(\lambda_k(0), 0]$ , we must have  $\lambda_k(\tilde{\varepsilon}) = 0$ . Otherwise,  $\lambda_j(\varepsilon) = \lambda_k(\varepsilon) \in (\lambda_k(0), 0]$  for some  $j > k$  and  $\varepsilon \in (0, \tilde{\varepsilon}]$  which is not possible by Theorem 5.3.4, part ii). Since  $0 \notin \sigma(L_0)$ ,  $\lambda_j(\varepsilon) < 0$  for all  $\varepsilon \in \mathbb{R}$  and  $j > k$ .

As consequence of this, the number of positive eigenvalues of  $L_\varepsilon$  is  $k - 1$  if  $\varepsilon < \tilde{\varepsilon}$  and  $k$  if  $\varepsilon > \tilde{\varepsilon}$  (see Figure 5).

Let  $\varepsilon_0 = -\frac{2v^2a'(\|\psi_x\|^2)}{a(\|\psi_x\|^2)^3}$ . Then, if  $a'(\|\psi_x\|^2) > vc'(\|\psi_x\|^2)$ , we have that  $\varepsilon_0 < \tilde{\varepsilon}$  and  $L_{\varepsilon_0}$  has exactly  $k - 1$  positive eigenvalues and  $0 \notin \sigma(L_{\varepsilon_0})$ . On the other hand, if  $a'(\|\psi_x\|^2) < c'(\|\psi_x\|^2)$ , we have that  $\varepsilon_0 > \tilde{\varepsilon}$  and  $L_{\varepsilon_0}$  has exactly  $k$  positive eigenvalues and  $0 \notin \sigma(L_{\varepsilon_0})$ .

Therefore, for all  $\varepsilon \in \mathbb{R}^+$ , the number of elements of  $\mathbb{R}^+ \cap \sigma(L_\varepsilon)$  is at least  $k - 1$ . □

**Remark 5.3.6.** The spectrum analysis is simpler when  $\psi = 0$ . In fact, the linearization of (5.3) at 0 is given by  $L^0 : D(L^0) \subset L^2(0, \pi) \rightarrow L^2(0, \pi)$ , where  $D(L^0) = H^2(0, \pi) \cap H_0^1(0, \pi)$  and

$$L^0 u = u_{xx} + \frac{\lambda}{a(0)}u, \quad u \in D(L^0).$$

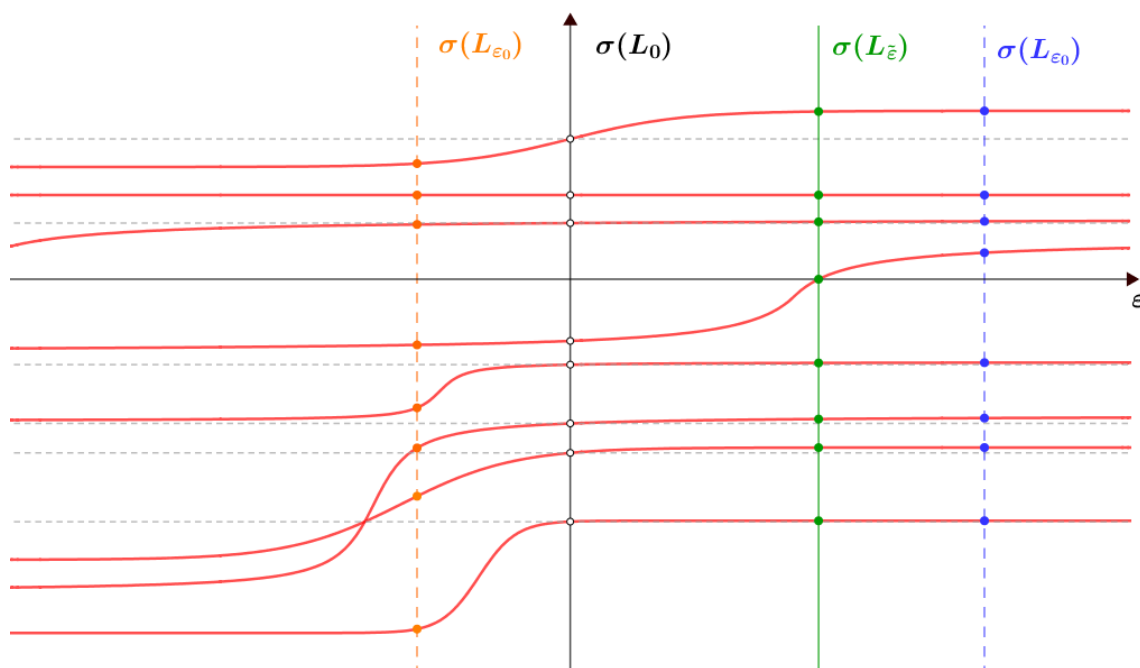
Figure 5 – Spectrum of  $L_\epsilon$ 

Above, we have used that  $f(0) = 0$  and  $f'(0) = 1$ . It is clear that  $\sigma(L^0) = \{-j^2 + \frac{\lambda}{a(0)} : j \in \mathbb{N}\}$ .

Hence, if  $\lambda \in (a(0)N^2, a(0)(N+1)^2)$ ,  $N \in \mathbb{N}$ , the equilibrium 0 is hyperbolic and

$$\sigma(L^0) \cap \mathbb{R}^+ = \left\{ -j^2 + \frac{\lambda}{a(0)} : j = 1, \dots, N \right\}.$$

Therefore, the Morse index of 0 is  $N$ .

**Remark 5.3.7.** Observe that the value  $a'(0)$  does not affect the hyperbolicity of 0. But it is relevant to determine what kind of the bifurcation happens at 0. We will see about this in Section 5.5.

**Corollary 5.3.8.** Consider (5.3) with the additional assumption of  $a$  being nondecreasing. Then all equilibria are hyperbolic. Moreover, if  $\phi$  is an equilibrium with  $k+1$  zeros in  $[0, \pi]$ , for some  $k \in \mathbb{N}$ , we have that its Morse index is  $i(\phi) = k - 1$ .

*Proof.* Since  $a$  is nondecreasing,  $a'(\|\phi_x\|^2) \geq 0 > c'(\|\phi_x\|^2)$ , which, by Theorem 5.3.5, implies that  $\phi$  is hyperbolic and its Morse index coincides with the number of zeros of  $\phi$  in  $(0, \pi)$ .  $\square$

## 5.4 Hyperbolicity of equilibria of the nonlocal quasilinear problem (5.1)

The traditional theory of hyperbolicity for quasilinear problems, as presented in (LUNARDI, 1995), cannot be applied to (5.1). We are dealing with a quasilinear equation, which

does not allow any approximation by a linear map as in Theorems 2.3.23 and 2.3.24. This inspired us to develop a concept of hyperbolicity that is based on the geometry properties of an hyperbolic equilibrium.

**Definition 5.4.1** (Topological Hyperbolicity). We say that  $\phi$  is topologically hyperbolic if  $\{\phi\}$  is an isolated invariant set. In other words, there exists a  $\delta > 0$  for which any global solution  $\xi : \mathbb{R} \rightarrow H_0^1(0, \pi)$ , with  $\sup_{t \in \mathbb{R}} \|\xi(t) - \phi\|_{H_0^1(0, \pi)} < \delta$ , satisfies  $\xi(t) = \phi$ , for all  $t \in \mathbb{R}$ .

As a consequence of that (see, (BORTOLAN; CARVALHO; LANGA, 2020)), any solution  $\eta^\pm : J^\pm \rightarrow H_0^1(0, \pi)$  of (5.1), with  $J^+ = [t_0, +\infty)$  or  $J^- = (-\infty, t_0]$ , such that  $\|\eta^\pm(t) - \phi\|_{H_0^1(0, \pi)} < \delta$  for all  $t \in J^\pm$ , satisfies  $\eta^\pm(t) \xrightarrow{t \rightarrow \pm\infty} \phi$ .

**Definition 5.4.2** (Local Stable  $W_{loc}^s(\phi)$  and Unstable Sets  $W_{loc}^u(\phi)$ ). Given a  $\delta$ -neighborhood  $\mathcal{O}_\delta(\phi) = \{u \in H_0^1(0, \pi) : \|u - \phi\|_{H_0^1(0, \pi)} < \delta\}$  of  $\phi$ ,  $\delta > 0$ , the associated local stable and unstable sets of  $\phi$ , respectively, are

$$\begin{aligned} W_{loc}^{s, \delta}(\phi) &= \{u \in H_0^1(0, \pi) : T(t)u \in \mathcal{O}_\delta, \text{ for all } t \geq 0, \text{ and } T(t)u \xrightarrow{t \rightarrow +\infty} \phi\}, \\ W_{loc}^{u, \delta}(\phi) &= \{u \in H_0^1(0, \pi) : \text{there exists a global solution } \xi \text{ of } \{T(t) : t \geq 0\} \text{ with } \xi(0) = u, \\ &\quad \xi(t) \in \mathcal{O}_\delta, \text{ for all } t \leq 0, \text{ and } \xi(t) \xrightarrow{t \rightarrow -\infty} \phi\}. \end{aligned}$$

When  $\phi$  is topologically hyperbolic and  $W_{loc}^{u, \delta}(\phi) = \{\phi\}$ , we say that  $\phi$  is asymptotically stable. Otherwise, it is said to be unstable.

**Definition 5.4.3** (Strict Hyperbolicity). We say that  $\phi$  is **hyperbolic** if there are closed subspaces  $X_u$  and  $X_s$  of  $H_0^1(0, \pi)$  with  $H_0^1(0, \pi) = X_u \oplus X_s$  such that

- $\{\phi\}$  topologically hyperbolic.
- The local stable and unstable sets are given as graphs of Lipschitz functions  $\theta_u : X_u \rightarrow X_s$  and  $\theta_s : X_s \rightarrow X_u$ , with Lipschitz constants  $L_s, L_u$  in  $(0, 1)$ ,  $\theta_u(0) = \theta_s(0) = 0$  and there exists  $\delta_0 > 0$  such that, given  $0 < \delta < \delta_0$ , there are  $0 < \delta'' < \delta' < \delta$  with

$$\begin{aligned} \{\phi + x_u + \theta_u(x_u) : x_u \in X_u, \|x_u\|_{H_0^1(0, \pi)} < \delta''\} &\subset W_{loc}^{u, \delta'}(\phi) \\ &\subset \{\phi + x_u + \theta_u(x_u) : x_u \in X_u, \|x_u\|_{H_0^1(0, \pi)} < \delta\} \\ \{\phi + \theta_s(x_s) + x_s : x_s \in X_s, \|x_s\|_{H_0^1(0, \pi)} < \delta''\} &\subset W_{loc}^{s, \delta'}(\phi) \\ &\subset \{\phi + \theta_s(x_s) + x_s : x_s \in X_s, \|x_s\|_{H_0^1(0, \pi)} < \delta\}. \end{aligned}$$

**Theorem 5.4.4.** An equilibrium  $\phi$  of (5.1) is hyperbolic in the sense of Definition 5.4.3 if  $\phi$  is hyperbolic for (5.3)

*Proof.* Suppose that  $\phi$  is hyperbolic in the sense of (5.3). Consider  $L_{c_\phi}$  as in (5.9) for  $c_\phi = \frac{-2\lambda^2 a'(\|\phi_x\|^2)}{a(\|\phi_x\|^2)^3}$ . Then, by Remark 2.3.11, there exist a projection  $P \in L(X)$  and constants  $M \geq 1$

and  $\gamma > 0$  such that

$$\begin{aligned} \|L_{c_\phi}(I - P)\|_{L(X)} &\leq Me^{-\gamma}, \quad \text{for } t \geq 0, \\ \|L_{c_\phi}(I - P)\|_{L(X)} &\leq Me^{\gamma}, \quad \text{for } t < 0. \end{aligned}$$

Denote by  $W_{loc}^{u,\delta}(\phi)$  the local unstable set of  $\phi$  of (5.3). Thus, we can apply Theorem 2.3.30 and we find such  $\delta_0 > 0$ , such that for each  $\delta \in (0, \delta_0)$ , there is a function  $\theta^s : (I - P)H_0^1(0, \pi) \rightarrow PH_0^1(0, \pi)$  and  $0 < \delta'' < \delta' < \delta$  such that

$$\begin{aligned} \{\phi + x + \theta^s(x) : x \in (I - P)H_0^1(0, \pi), \|x\|_{H_0^1(0, \pi)} < \delta''\} &\subset W_{loc}^{s,\delta'}(\phi) \\ &\subset \{\phi + x + \theta^s(x) : x \in (I - P)H_0^1(0, \pi) : \|x\|_{H_0^1(0, \pi)} < \delta\}. \end{aligned}$$

Denote by  $\tilde{W}_{loc}^{s,\delta}(\phi)$  the local stable set of  $\phi$  given by (5.1). We can also see that  $\tilde{W}_{loc}^{s,\delta}(\phi) = W_{loc}^{s,\delta}(\phi)$ .

Therefore, the result follows. □

**Corollary 5.4.5.** Consider (5.1) with the additional assumption of  $a$  being non-decreasing. Then all equilibria of (5.3) are hyperbolic, with the exception of 0 when  $\lambda = a(0)n^2$ ,  $n \in \mathbb{N}$ .

The proof of the Corollary above is made in (CARVALHO; MOREIRA, 2021), with the additional assumption of  $f$  being odd. In section 5.6, we will see that we can drop such assumption and the claim remains valid.

In the next section, we will make an analysis based on the graphs for which we can study the bifurcation and hyperbolicity of equilibria.

## 5.5 Bifurcation of equilibria for a few examples

As we have seen in the previous Sections, for the hyperbolicity of equilibria of (5.3), and consequently of (5.1), it is important to know the value of the derivative of  $a$  in the  $H^1$ -norm in that point.

There is one exception, when the equilibrium is 0, for which the hyperbolicity is determined only by the value of the parameter  $\lambda > 0$ . But we will see that in fact, understanding the value of  $a'(0)$  may help us to understand the local bifurcation at 0.

**Proposition 5.5.1.** Consider  $j \in \mathbb{N}$ ,  $i \in \{+, -\}$  and  $v_0 = a(0)j^2$ . We have the following:

- (i) If  $a'(0) > v_0(c_j^i)'(0)$ , then we have a supercritical bifurcation at 0 for equilibrium of type  $\phi_j^i$ . That is, an equilibrium bifurcates at 0 as  $v > v_0$  increases.
- (ii) If  $a'(0) < v_0(c_j^i)'(0)$ , then an equilibrium of type  $\phi_j^i$  collapses at 0 as  $v < v_0$  increases.

*Proof.* We will prove item (i) and the item (ii) will follow analogously.

- (i) Since  $a(0) = v_0 c_j^i(0)$  and  $a'(0) > v_0 (c_j^i)'(0)$  there is a  $R > 0$  such that  $a(r) > v_0 (c_j^i)(r)$  and  $a'(r) > v_0 (c_j^i)'(r)$ , for  $r \in (0, R]$ . For simplicity, denote  $c_j^i(\cdot)$  by  $c(\cdot)$ .

It is clear that for  $v \in (0, v_0)$ ,  $a(r) \geq v_0 (c_j^i)(r) > v (c_j^i)(r)$ , for all  $r \in [0, R]$ . Hence, for  $v \in (0, v_0)$ , there does not exist any equilibrium of type  $\phi_j^i$  near 0.

Let  $\bar{v} > v_0$  be such that  $a(R) > \bar{v} c_j^i(R)$ . Note that  $\bar{v} c(0) > v_0 c(0) = a(0)$ . Since  $c$  is continuous and by the Intermediate Value Theorem, it is clear that there is  $\bar{r} \in (0, R)$  such that  $\bar{v} c(\bar{r}) = a(\bar{r})$ .

Recall that  $a'(r) - v_0 c'(r) > 0$ , for  $r \in (0, R]$ . Consequently, using that  $c$  is strictly decreasing, we have, for all  $v$

$$a'(r) - v c'(r) > 0, \text{ for all } r \in (0, R]. \quad (5.10)$$

For  $v \in (v_0, \bar{v})$ , it follows that  $v c(0) > v_0 c(0) = a(0)$  and  $c(\bar{r}) < \bar{v} c(\bar{r}) = a(\bar{r})$ . Again, by the Intermediate Value Theorem and (5.10), we can choose a unique  $r_v \in (0, \bar{r})$  such that

$$a(r_v) = v c(r_v) \text{ and } a(r) < v c(r), \text{ for } r \in (0, r_v).$$

Consider the map

$$g : (v_0, \bar{v}) \rightarrow (0, \bar{r})$$

given by  $g(v) = r_v$ . We will show that  $g$  is continuous.

Take  $\tilde{v} \in (v_0, \bar{v})$ . For all  $\varepsilon > 0$ , we want to show that there is a  $\delta > 0$  such that, for  $v \in (v_0, \bar{v})$ ,  $0 < |v - \tilde{v}| < \delta$  implies  $|r_v - r_{\tilde{v}}| < \varepsilon$ .

We can always suppose that we choose  $\varepsilon$  sufficiently small such that  $0 < r_1 = r_{\tilde{v}} - \varepsilon < r_2 = r_{\tilde{v}} + \varepsilon < \bar{r}$ . Now, we have

$$a(r_1) > v_0 c(r_1) \text{ and } a(r_1) < \tilde{v} c(r_1), \text{ since } r_1 < r_{\tilde{v}},$$

and

$$a(r_2) > v_0 c(r_2) \text{ and } a(r_2) < \bar{v} c(r_2), \text{ since } r_2 < \bar{r}.$$

Then, there are  $v_1 \in (v_0, \tilde{v})$  and  $v_2 \in (v_0, \bar{v})$  such that  $a(r_1) = v_1 c(r_1)$  and  $a(r_2) = v_2 c(r_2)$ . Now, it is clear that, for  $j = 1, 2$ ,

$$\begin{aligned} a(r_j) &> v c(r_j), \text{ for all } v \in (v_0, v_j), \\ a(r_j) &< v c(r_j), \text{ for all } v \in (v_j, +\infty), \end{aligned} \quad (5.11)$$

and, by (5.10),  $r_j = r_{v_j}$ .

We can see that  $\tilde{v} - v_1 > 0$  by (5.11). Also  $v_2 - \tilde{v} > 0$ . In fact, we have

$$v_2 c(r_{\tilde{v}}) > v_2 c(r_2) = a(r_2) > a(r_{\tilde{v}}) = \tilde{v} c(r_{\tilde{v}}),$$



which implies  $v_2 - \tilde{v} > 0$ .

Take  $\delta = \min\{\tilde{v} - v_1, v_2 - \tilde{v}\} > 0$ . Then, it follows that  $r_v \in (r_{\tilde{v}} - \varepsilon, r_{\tilde{v}} + \varepsilon)$ .

Therefore,  $g$  is continuous. In particular, as  $v \rightarrow v_0$ , it follows that  $r_v \rightarrow 0$ .

□

**Remark 5.5.2.** When the nonlinearity  $f$  is odd we have  $c_j^+(\cdot) = c_j^-(\cdot)$ , for all  $j \in \mathbb{N}$ . In particular the number of positive and negative equilibria are the same.

Denote by  $c_{j,\pm}^L(\cdot)$ ,  $L > 0$ ,  $j \in \mathbb{N}$ , the function  $c_k^\pm(\cdot)$  related to the solutions that have  $j+1$  zeros in  $[0, \pi]$  of

$$\begin{cases} u_{xx} + \lambda f(u) = 0, & x \in (0, L), \\ u(0) = u(L) = 0 \end{cases} \quad (5.12)$$

for  $\lambda > 0$  a parameter.

Recall that the following holds:

**Lemma 5.5.3.** If  $f$  is as before, for all  $j \in \mathbb{N}$ ,  $j \geq 2$ , if  $\phi_j$  an equilibrium of (3.1) with  $j-1$  zeros in  $(0, \pi)$ , then  $\phi_{2j}$  is  $\frac{\pi}{j}$  periodic. In addition, if  $f$  is odd then  $\phi_j(\frac{\pi}{j} + x) = -\phi_j(\frac{\pi}{j} - x)$ ,  $x \in [0, \frac{\pi}{j}]$ . Additionally, for  $k = 1, \dots, j-1$ ,

$$\phi_{2j}(x) = \phi_{2j}(x + k\frac{\pi}{j}), \text{ for all } x \in [0, \frac{(j-k)\pi}{j}].$$

**Proposition 5.5.4.** If  $f$  is as before then,

(i)  $c_{j,\pm}^L(r) = (\frac{L}{\pi})^2 c_{j,\pm}^\pi(\frac{Lr}{\pi})$ , for all  $r \in \mathbb{R}^+$ ,  $j = 1, 2, 3, \dots$ .

(ii) For all  $r \in \mathbb{R}^+$ ,  $c_2^L(r) = (\frac{L}{\pi})^2 c_2^\pi(\frac{Lr}{\pi})$ .

(iii) For all  $r \in \mathbb{R}^+$ ,  $c_{2j,\pm}^\pi(r) = \frac{1}{j^2} c_{2,\pm}^\pi(\frac{r}{j^2})$ .

If we also assume that  $f$  is odd then,

(iv)  $c_{j,+}^L(\cdot) = c_{j,-}^L(\cdot)$  and  $c_{j,\pm}^\pi(r) = c_{1,\pm}^\pi(\frac{r}{j})$ , for all  $r \in \mathbb{R}^+$  and  $j \in \mathbb{N}$ .

(v)  $c_{j,+}^L(\cdot) = c_{j,-}^L(\cdot)$  and  $c_{j,\pm}^\pi(r) = \frac{1}{j^2} c_{1,\pm}^\pi(\frac{r}{j})$ , for all  $r \in \mathbb{R}^+$  and  $j \in \mathbb{N}$ .

*Proof.* The proof follows by a simple change of variables.

(i) Fix  $r \in \mathbb{R}^+$ . In what follows we fix one of the symbols  $+$  or  $-$  and omit it in the notation.

If  $c_j^L(r) = \frac{1}{\lambda_r}$ , then there is a  $\phi \in C^2[0, L]$ , with  $\|\phi_x\|^2 = r$ , such that  $\phi \neq 0$  in  $(0, \pi)$  and satisfies (5.12) with  $\lambda$  replaced by  $\lambda_r$ .

For  $x \in [0, \pi]$ , define  $\psi(x) = \phi(\frac{Lx}{\pi})$ . Then  $\psi$  satisfies

$$\psi_{xx}(s) = \left(\frac{L}{\pi}\right)^2 \phi_{xx}\left(\frac{Ls}{\pi}\right) = -\left(\frac{L}{\pi}\right)^2 \lambda_r f\left(\phi\left(\frac{Ls}{\pi}\right)\right).$$

In other words,  $\psi$  is a solution of (5.12) with  $L$  replaced by  $\pi$  and  $\lambda$  replaced by  $(\frac{L}{\pi})^2 \lambda_r$ . Also,

$$\|\psi_x\|^2 = \int_0^\pi (\psi_x(s))^2 ds = \int_0^\pi \left(\frac{L}{\pi}\right)^2 \phi_x\left(\frac{Ls}{\pi}\right)^2 ds = \frac{L}{\pi} \int_0^L \phi_x(u)^2 du = \frac{Lr}{\pi}.$$

Hence, by definition of  $c_j^\pi$ , we conclude that  $c_j^\pi(\frac{Lr}{\pi}) = (\frac{\pi}{L})^2 \frac{1}{\lambda_r}$ .

Therefore,  $c_j^L(r) = \frac{1}{\lambda_r} = (\frac{L}{\pi})^2 c_j^\pi(\frac{Lr}{\pi})$ . Since  $r \in \mathbb{R}^+$  is arbitrary, the result follows.

(ii) Fix  $r > 0$ . By definition,  $c_2^L(r) = \frac{1}{\lambda_r}$  implies that there is a  $\phi$  is a solution of (5.12) with  $\lambda$  replaced by  $\lambda_r$ ,  $\phi$  changes sign one time in  $(0, L)$  with  $\|\phi_x\|^2 = r$ .

Define  $\psi(x) = \phi(\frac{Lx}{\pi})$ , for  $x \in [0, \pi]$ . Then  $\psi$  satisfies

$$\psi_{xx} = (\frac{L}{\pi})^2 \phi_{xx}(\frac{Ls}{\pi}) = -(\frac{L}{\pi})^2 \lambda_r f(\phi(\frac{Ls}{\pi})).$$

Consequently, in  $(0, \pi)$ ,

$$\psi_{xx} + \lambda_r (\frac{L}{\pi})^2 f(\psi) = 0.$$

Also,  $\psi(0) = \psi(\pi) = 0$  and

$$\int_0^\pi (\psi_x(s))^2 ds = \int_0^\pi (\frac{L}{\pi})^2 (\phi_x(\frac{Ls}{\pi}))^2 ds = \frac{L}{\pi} \int_0^L (\phi_x(u))^2 du = \frac{Lr}{\pi}.$$

Thus,  $c_2^\pi(\frac{Lr}{\pi}) = (\frac{\pi}{L})^2 \frac{1}{\lambda_r} = (\frac{\pi}{L})^2 c_2^L(r)$ .

(iii) Once again, we fix one of the symbols  $+$  or  $-$  and omit it in the notation. Fix  $r \geq 0$  and  $j \in \mathbb{N}$ ,  $j \geq 2$ . By the definition,  $c_{2j}^\pi(r) = \frac{1}{\lambda_r}$  implies that there is a  $\phi$ , with  $2j - 1$  zeros in  $(0, \pi)$ , equilibrium of (3.1) when  $\lambda = \lambda_r$  and satisfying  $\|\phi_x\|^2 = r$ .

By Lemma 5.5.3, we have that  $r = \int_0^\pi (\phi_x(s))^2 ds = j \int_0^{\frac{\pi}{j}} (\phi_x(s))^2 ds$ .

Hence  $\psi = \phi_x|_{[0, \frac{\pi}{j}]}$  is the solution of (5.12) that changes sign one time for  $L = \frac{\pi}{j}$ .

Therefore,  $c_2^{\frac{\pi}{j}}(\frac{r}{j}) = \frac{1}{\lambda_r} = c_{2j}^\pi(r)$ . By the previous item, it follows the desired result.

(iv) Fix  $j \in \mathbb{N}$  and  $r \in \mathbb{R}^+$ . If  $c_j^\pi(r) = \frac{1}{\lambda_r}$ , then there is  $\phi \in C^2(0, \pi)$  with  $j - 1$  zeros in  $(0, \pi)$ , with  $\|\phi_x\|^2 = r$ , and satisfying (3.1). Since  $f$  is odd,  $\phi$  has a lot of symmetries and

$$r = \int_0^\pi (\psi_x(s))^2 ds = j \int_0^{\frac{\pi}{j}} (\psi_x(s))^2 ds.$$

Consider  $\psi = \phi|_{[0, \frac{\pi}{j}]}$ . Then, we have  $\psi > 0$  in  $(0, \pi)$ ,  $\|\psi_x\|^2 = \frac{r}{j}$ , and  $\psi$  satisfies (5.12) for  $L = \frac{\pi}{j}$  and  $\lambda = \lambda_r$ .

Hence, by the definition of  $c_1^{\frac{\pi}{j}}$ , we find  $c_1^{\frac{\pi}{j}}(\frac{r}{j}) = \frac{1}{\lambda_r} = c_j^\pi(r)$ .

(v) It follows from the previous items.

□

Consider the problem (5.1) with the additional assumption of  $f$  is odd. In that case, we are able to construct a relation for the functions  $c_k^\pm$ ,  $k \in \mathbb{R}^+$ . Remember that in this case, for all  $k \in \mathbb{N}$ ,  $c_k^+ = c_k^-$ , so we will simply denote it by  $c_k(\cdot)$ .

The result from Proposition 5.5.4 give provides a very good understanding of the bifurcations of equilibria for (5.1) with particular emphasis to the case of suitably large  $j \in \mathbb{N}$ . We remark that, for large values of  $j$  the functions  $j^2 c_j(\pm)$  are very slowly decreasing.

Next we exhibit a few pictorial examples of possible bifurcations that will happen depending on our choice of the functions  $a$  and  $f$ .

**Example 5.5.5.** Consider in this example the function  $a = a_1$  as in Figure 6:

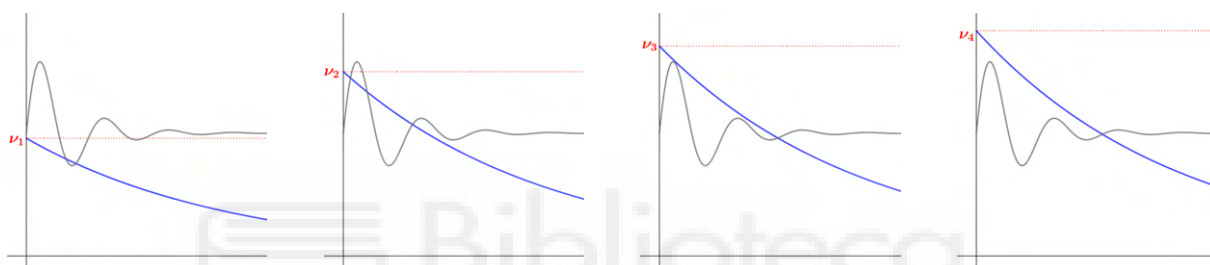
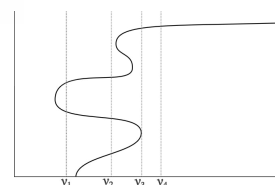

Figure 6 – Graphs of  $a_1$  (in gray) and  $v c_1^\pm$  (in blue) for different choices of  $v$

In that case, the bifurcation from zero is a supercritical pitchfork bifurcation and four other saddle-node bifurcations occur, two subcritical and two supercritical. The bifurcation curve looks like this:



**Example 5.5.6.** Consider in this example the function  $a = a_2$ , with a graph pictured in gray, in Figure 7:

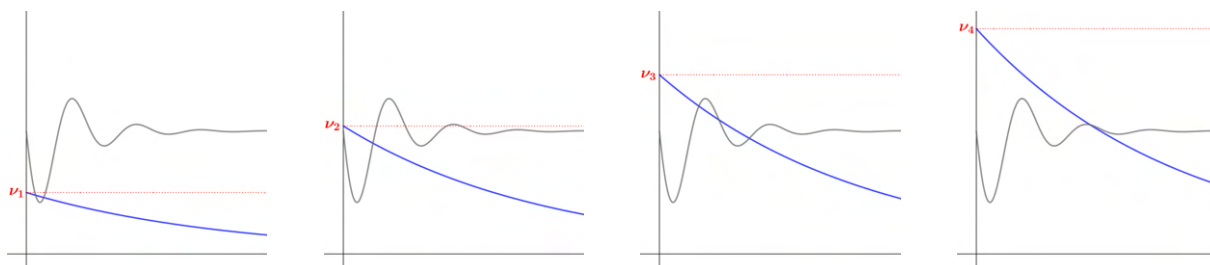
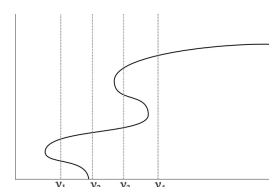

Figure 7 – Graphs of  $a_2$  and  $v c_1^\pm$  (in blue) for different choices of  $v$

In that case, the bifurcation from zero is a subcritical pitchfork bifurcation and three other saddle-node bifurcations occur, two supercritical and one subcritical. The bifurcation curve looks like this:



**Example 5.5.7.** Consider the function given by  $a = a_3$ , with graph pictured in gray, as in Figure 8.

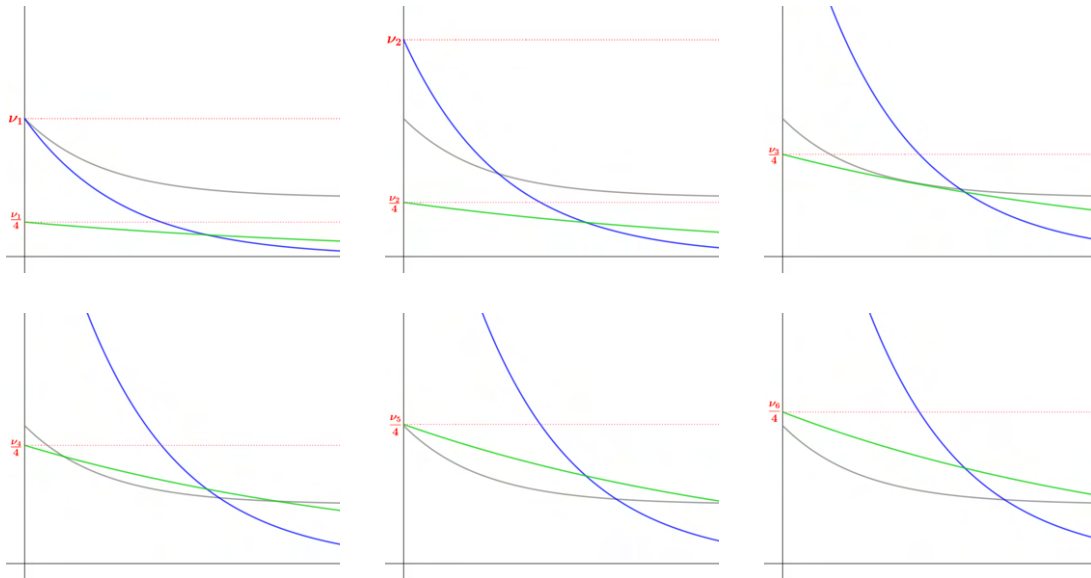
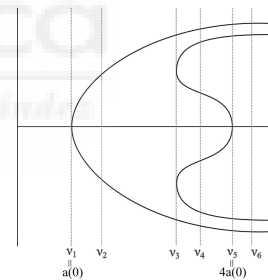

Figure 8 – Graphs of  $a_3$  (in gray),  $vc_1^\pm$  (in blue) and  $vc_2^\pm$  (in green) for different choices of  $v$

The first bifurcation from zero is a supercritical pitchfork bifurcation and the second bifurcation from zero is a supercritical saddle-node bifurcation.

In this case, the diagram representing the two bifurcations from zero is similar to the figure:



Suppose that  $v_3 \in (v_1, v_5)$  is the moment for which the saddle-node bifurcation of the equilibria that change sign one time in  $(0, \pi)$  appears. In this case, if  $f$  is odd, a pictorial representation of the global attractor is given in Figure 9.

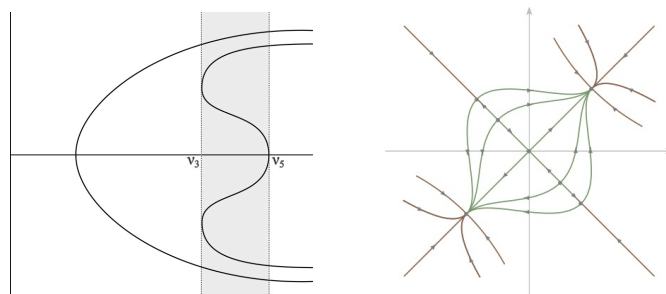

Figure 9 – Expected structure of the attractor, when  $v \in (v_3, v_5)$ .

For  $v \in (v_3, v_5)$ , it is also expected that the two more unstable equilibria collapses at 0 as  $v$  approaches  $4a(0)$ .

**Example 5.5.8.** Consider in this example the function  $a = a_4$  as in Figure 10:

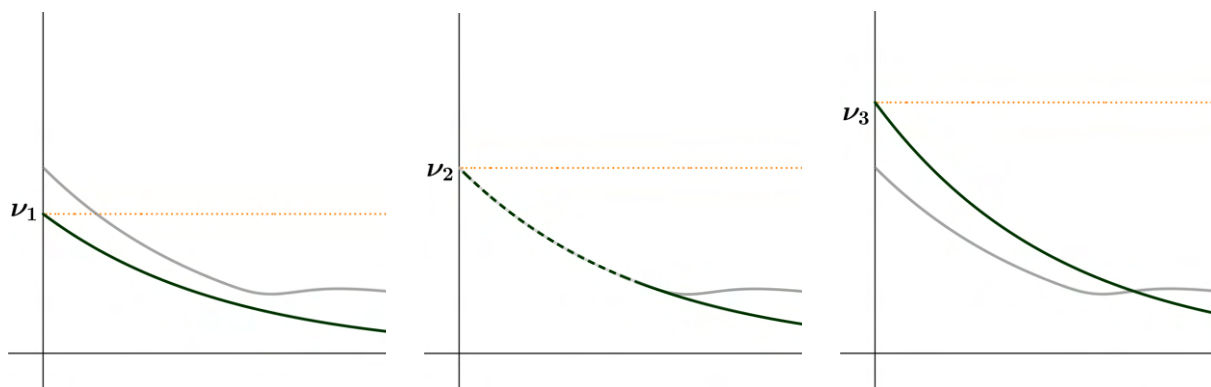
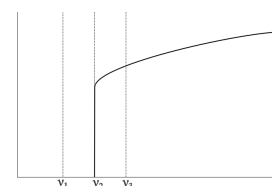

Figure 10 – Graphs of  $a_4$  (in gray) and  $vc_1^\pm$  (in green) for different choices of  $v$

In this case, for  $v < v_2 = a(0)$ , there are no equilibria of types  $\phi_1^+$ . At  $v = v_2$ , it appears infinite equilibria from a bifurcation at zero. As  $v$  increases, there remains only one equilibrium.



**Example 5.5.9.** Consider in this example the function  $a = a_5$  as in Figure 11:

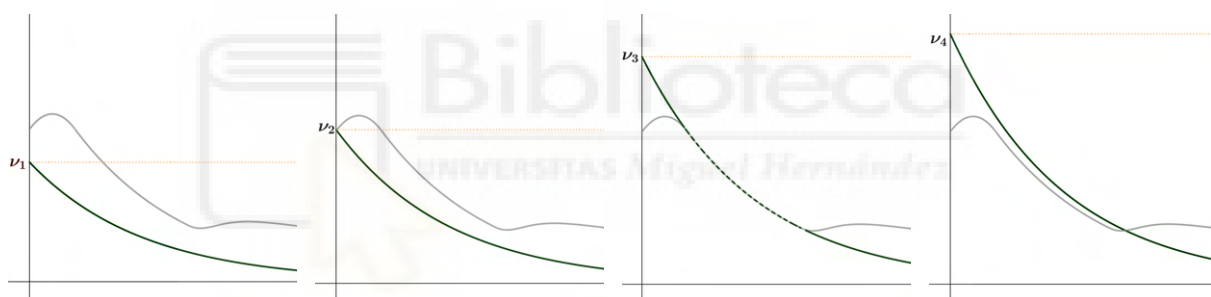
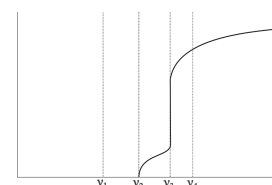

Figure 11 – Graphs of  $a_5$  (in gray) and  $vc_1^\pm$  (in green) for different choices of  $v$

In that case, the bifurcation from zero is supercritical and there are no equilibria for  $v < v_2$ . For  $v = v_3$ , the non-zero equilibrium bifurcates to an interval of equilibria, which collapses to one as  $v$  increases.



**Example 5.5.10.** Consider in this example the function  $a = a_6$  as in Figure 12:

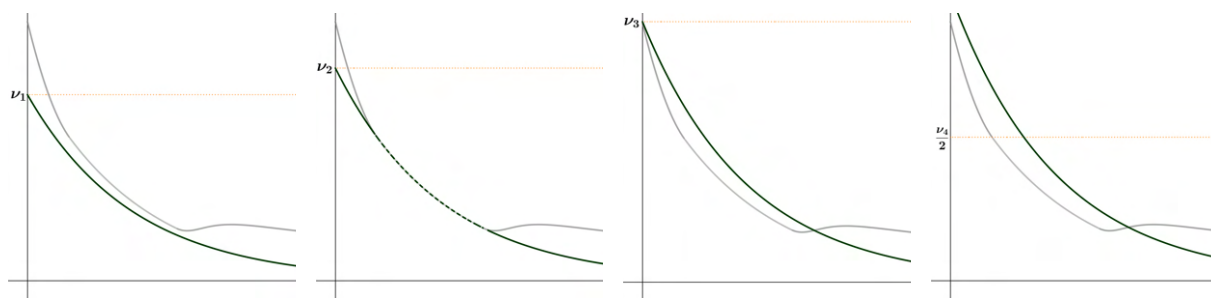
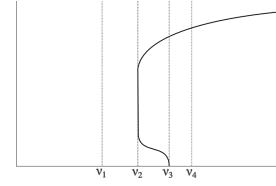

Figure 12 – Graphs of  $a_6$  (in gray) and  $vc_1^\pm$  (in green) for different choices of  $v$

For  $v < v_2$ , there are no equilibria of (5.1). At  $v = v_2$ , there is a bifurcation with the appearance of an interval of equilibria (far from zero). As  $v$  increases, this interval collapses in one equilibrium.



## 5.6 Structure of the global attractor for $a$ non-decreasing

In this section, we will assume that  $a$  is non-decreasing and that  $f$  odd. We will prove that, with the addition of both assumptions, we are able to fully describe the connections inside the global attractor of (5.3) (and consequently, the global attractor of (5.1)).

To prove such result, we will show that (5.3) satisfies properties (A1) to (A4) described in Section 3.3.

**Lemma 5.6.1.** Suppose that  $a(0)N^2 < \lambda < a(0)(N+1)^2$ ,  $N \in \mathbb{N}$ . Under the same notation of Theorem 5.2.6, let  $\phi \in \{\phi_{N,\lambda}^+, \phi_{N,\lambda}^-\}$  and, for  $\tau \in [0, 1]$ , consider

$$\begin{cases} u_t = a_\tau(\|u_x\|^2)u_{xx} + \lambda f(u), & x \in (0, \pi), t > 0, \\ u(t, 0) = u(t, \pi) = 0, & t \geq 0, \\ u(0, \cdot) = u_0 \in H_0^1(0, \pi), \end{cases} \quad (5.13)$$

for  $a_\tau(s) = a(\tau s + (1-\tau)\|\phi_x\|^2)$ ,  $a: \mathbb{R}^+ \rightarrow [m, M]$  and  $f$  satisfying the same conditions imposed in (3.2).

For  $\tau \in [0, 1]$ ,  $\mathcal{E}^\tau$  will denote the set of equilibria of (5.13),  $\tau \in [0, 1]$ . Then  $\mathcal{E}^\tau$  is a set with  $2N+1$  elements, for all  $\tau \in [0, 1]$ . Moreover, we have continuity of equilibria at  $\tau = 0$ .

*Proof.* The function  $a_\tau: \mathbb{R} \rightarrow [m, M]$  given by  $a_\tau(s) = a(\tau s + (1-\tau)\|\phi_x\|^2)$  is globally Lipschitz continuous and  $a_\tau$  is also a non-decreasing  $C^1$ -function, for each  $\tau \in [0, 1]$ . So, these problems are well-defined and we have a semigroup  $\{S_\tau(t) : t \geq 0\}$  related to (5.13), for all  $\tau \in [0, 1]$ .

First, we will show that the cardinal number of  $\mathcal{E}^\tau$  is the same for all  $\tau \in [0, 1]$ . Observe that  $a(\|\phi_x\|^2)N^2 < \lambda$ , since  $\phi$  is an equilibrium for

$$\begin{cases} u_t = u_{xx} + \frac{\lambda}{a(\|\phi_x\|^2)}f(u), & x \in (0, \pi), t > 0, \\ u(t, 0) = u(t, \pi) = 0, & t \geq 0, \\ u(0, \cdot) = u_0 \in H_0^1(0, \pi). \end{cases}$$

Using that  $a$  is non-decreasing, for all  $\tau \in [0, 1]$ , we have  $a_\tau(0)N^2 = a((1-\tau)\|\phi_x\|^2)N^2 \leq a(\|\phi_x\|^2)N^2 < \lambda$  and, on the other hand,  $\lambda \leq a(0)(N+1)^2 \leq a_\tau(0)(N+1)^2$ .

Therefore, for each  $\tau \in [0, 1]$ , the problem (5.13) has exactly  $2N+1$  equilibria.

Now, suppose that  $\{\tau_n\}_{n \in \mathbb{N}} \subset [0, 1]$  and  $\tau_n \rightarrow \tau_0$  as  $n \rightarrow +\infty$ . Denote

$$\mathcal{E}^{\tau_n} = \left\{ \phi_{j,(n)}^{\pm} : j = 0, \dots, N \right\}$$

where  $\phi_{0,(n)}^+ = \phi_{0,(n)}^- = 0$  and  $\phi_{j,(n)}^i$  has  $j + 1$  zeros in  $[0, \pi]$ ,  $i(\phi_{j,(n)}^i)_x(0) > 0$ , for  $i \in \{+, -\}$  and  $j = 0, \dots, N$ . We will prove the continuity of  $\mathcal{E}^{\tau}$  in terms of the parameter  $\tau \in [0, 1]$ .

For that, fix a  $j \in \{0, 1, \dots, N\}$  and denote by  $\psi^{(n)} = \phi_{j,(n)}^+$ ,  $n \in \mathbb{N}$ . For each  $n \in \mathbb{N}$ ,

$$a_{\tau_n}(\|(\psi^{(n)})_x\|^2)(\psi^{(n)})_{xx} + \lambda f(\psi^{(n)}) = 0.$$

Multiplying the above equation by  $\psi^{(n)}$ , we find

$$\|(\psi^{(n)})_x\|^2 \leq \frac{1}{a(0)} \left\langle \lambda f(\psi^{(n)}), \psi^{(n)} \right\rangle \leq C + \frac{1}{2} \|(\psi^{(n)})_x\|^2,$$

for some  $C > 0$ , where we have used the conditions on  $f$  and Sobolev's embeddings.

Therefore, this sequence is relatively compact in  $L^2(0, \pi)$  and we may assume that it is convergent to some  $\psi \in L^2(0, \pi)$ . Since  $H_0^1(0, \pi) \subset C([0, 1])$ , the sequence  $\{\psi^{(n)}\}_{n \in \mathbb{N}}$  is also bounded in  $C([0, 1])$  so as the sequence  $\{f(\psi^{(n)})\}_{n \in \mathbb{N}}$ , by the continuity of  $f$ .

Consequently,

$$\|(\psi^{(n)})_{xx}\| \leq \frac{\lambda}{a(0)} \|f(\psi^{(n)})\| < +\infty$$

and  $\{\psi^{(n)}\}_{n \in \mathbb{N}}$  is bounded in  $H^2(0, \pi)$ . Since  $H^2(0, \pi)$  is compactly embedded in  $H_0^1(0, \pi)$ , we may assume that the sequence is convergent to some  $\tilde{\psi} \in H_0^1(0, \pi)$ .

Now,  $H^1(0, \pi) \subset L^2(0, \pi)$  and by the uniqueness of the limit, it follows that  $\tilde{\psi} = \psi$ .

Observe that  $\psi^{(n)} \rightarrow \psi$  in  $C^1([0, \pi])$ , since  $H^2(0, \pi) \subset C^1([0, 1])$  and such embedding is compact. For any  $v \in H_0^1(0, \pi)$  and  $n \in \mathbb{N}$ ,

$$-a_{\tau_n}(\|(\psi^{(n)})_x\|^2) \left\langle (\psi^{(n)})_x, v_x \right\rangle + \lambda \left\langle f(\psi^{(n)}), v \right\rangle = 0,$$

hence

$$-a_{\tau_0}(\|\psi_x\|^2) \langle \psi_x, v_x \rangle + \lambda \langle f(\psi), v \rangle = 0.$$

Now, using that  $\psi \in H^2(0, \pi)$  since  $\phi^{(n)} \rightarrow \psi$  weakly in  $H^2(0, \pi)$ , we conclude that

$$-a_{\tau_0}(\|\psi_x\|^2) \psi_{xx} + \lambda f(\psi) = 0.$$

Therefore,  $\psi$  is an equilibrium of (5.13) for  $\tau = \tau_0$ .

In the case  $\phi^{(n)} = \phi_{0,(n)}^+ = 0$ , for all  $n \in \mathbb{N}$ , we find  $\psi = 0$  and we are done. So, suppose  $j \neq 0$ . We only need to show that  $\psi \neq 0$ . For that, consider  $b = \inf_{n \in \mathbb{N}} \lambda [a_{\tau_n}(\|(\psi^{(n)})_x\|^2)]^{-1} > 0$ . For any  $\bar{\lambda} > N^2$ , let  $\phi^{\bar{\lambda}}$  satisfying

$$\phi_{xx}^{\bar{\lambda}} + \bar{\lambda} f(\phi^{\bar{\lambda}}) = 0$$

with  $\varphi^{\bar{\lambda}}$  having  $j + 1$  zeros in  $[0, \pi]$  and  $\varphi_x^{\bar{\lambda}}(0) > 0$ . One important result is that the function

$$(n^2, +\infty) \ni \bar{\lambda} \mapsto \|\varphi_x^{\bar{\lambda}}\|$$

is increasing, see (CABALLERO *et al.*, 2021).

In particular,  $0 < \|\varphi_x^b\| \leq \|\varphi_x^{r_n}\|$  for  $r_n = \lambda[a_{\tau_n}(\|\psi^{(n)}\|_x^2)]^{-1}$ ,  $n \in \mathbb{N}$ . Since  $\varphi_x^{r_n} = \psi^{(n)}$ ,  $n \in \mathbb{N}$ , and  $\psi^{(n)} \rightarrow \psi$ , we find  $0 < \|\varphi_x^b\| \leq \|\psi_x\|$ .

We conclude that  $\psi = \phi_{j,+}^{\tau_0}$  by the  $C^1$  convergence and we have the continuity of equilibria.

The case  $\psi^{(n)} = \phi_{j,(n)}^-$ ,  $n \in \mathbb{N}$ , is similar, thus it will not be treated.  $\square$

**Lemma 5.6.2.** For any  $\tau \in [0, 1]$ , denote by  $\{S_\tau(t) : t \geq 0\}$  the semigroup related to (5.13). This family of semigroups is continuous, that is, given sequences  $\{\tau_n\}_{n \in \mathbb{N}}$ ,  $\tau_0 \in [0, 1]$ ,  $\{u_0^{(n)}\}_{n \in \mathbb{N}}$ ,  $u_0 \in H_0^1(0, \pi)$ ,  $\{t_n\}_{n \in \mathbb{N}}$ ,  $t_0 \in \mathbb{R}^+$  satisfying

$$u_0^{(n)} \rightarrow u_0 \text{ in } H_0^1(0, \pi), \tau_n \rightarrow \tau_0, \text{ and } t_n \rightarrow t_0, \text{ as } n \rightarrow +\infty, \quad (5.14)$$

we have  $\|S_{\tau_n}(t_n)u_0^{(n)} - S_{\tau_0}(t)u_0\|_{H_0^1(0,\pi)} \rightarrow 0$  as  $n \rightarrow +\infty$ .

*Proof.* For any  $t > 0$ , denote  $u(t) = S_{\tau_0}(t)u_0$  and  $u_n(t) = S_{\tau_n}(t)u_0^{(n)}$ ,  $n \in \mathbb{N}$ .

Consider  $Au = u_{xx}$ ,  $u \in H^2(0, \pi) \cap H_0^1(0, \pi)$ , see Example 2.3.12. By the formula of variation of constants,

$$u_n(t) = e^{At}u_0^{(n)} + \int_0^t e^{A(t-s)} \frac{f(u_n(s))}{a_{\tau_n}(\|(u_n)_x(s)\|^2)} ds, \quad n \in \mathbb{N},$$

and

$$u(t) = e^{At}u_0 + \int_0^t e^{A(t-s)} \frac{f(u(s))}{a_{\tau_0}(\|u_x(s)\|^2)} ds.$$

We may assume, without loss of generality that  $\{t_n\}_{n \in \mathbb{N}} \subset [0, T]$ , for some  $T \in \mathbb{R}^+$  and  $t_n > t_0$  for  $n$  sufficiently large. We may define

$$C_f = \sup_{n=0,1,2,\dots} \{ |f(v(x))| : v \in S_{\tau_n}([0, T])u_n, x \in [0, \pi] \} < +\infty.$$

The uniform boundedness follows by using comparison between problems (5.3) with  $a(\cdot)$  replaced by  $a_{\tau_n}(\cdot)$ ,  $n \in \mathbb{N}$ , and (5.3) with  $f(\cdot)$  replaced by  $g(\cdot) = f(\cdot)/m$ . See Theorem 2.3.20, for the abstract comparison result.

Now,

$$\begin{aligned} \|u(t_n) - u(t_0)\|_{H_0^1(0,\pi)} &\leq \|(e^{A(t_n-t_0)} - I)u(t_0)\|_{H_0^1(0,\pi)} + \int_{t_0}^{t_n} \left\| e^{A(t_n-s)} \frac{f(u(s))}{a_{\tau_0}(\|u_x(s)\|^2)} \right\|_{H_0^1(0,\pi)} ds \\ &\leq \|(e^{A(t_n-t_0)} - I)u(t_0)\|_{H_0^1(0,\pi)} + \frac{C_f \pi^{\frac{1}{2}}}{m} \int_{t_0}^{t_n} e^{-(t_n-s)} (t_n - s)^{-\frac{1}{2}} ds. \end{aligned}$$



We can see that, assuming  $|t_n - t_0| < 1$ , we find

$$\begin{aligned} \int_{t_0}^{t_n} e^{-(t_n-s)} (t_n-s)^{-\frac{1}{2}} ds &= \int_0^{t_n-t_0} e^{-u} u^{-\frac{1}{2}} du = 2e^{-(t_n-t_0)} (t_n-t_0)^{\frac{1}{2}} + \int_0^{t_n-t_0} 2e^{-u} u^{\frac{1}{2}} du \\ &\leq 2(t_n-t_0)^{\frac{1}{2}} + 2(t_n-t_0). \end{aligned}$$

Hence

$$\|u(t_n) - u(t_0)\|_{H_0^1(0,\pi)} \leq \|(e^{A(t_n-t_0)} - I)u(t_0)\|_{H_0^1(0,\pi)} + 4\frac{C_f\pi^{\frac{1}{2}}}{m}(t_n-t_0)^{\frac{1}{2}}. \quad (5.15)$$

Also, for  $I(s) = |a_{\tau_0}(\|u_x(s)\|^2) - a_{\tau_n}(\|(u_n)_x(s)\|^2)|$ ,

$$\left\| \frac{f(u_n(s))}{a_{\tau_n}(\|(u_n)_x(s)\|^2)} - \frac{f(u(s))}{a_{\tau_0}(\|u_x(s)\|^2)} \right\| \leq \frac{a_{\tau_0}(\|u_x(s)\|^2) \|f(u_n(s)) - f(u(s))\| + I(s) \|f(u(s))\|}{m^2}.$$

Now, since  $a$  is globally Lipschitz, there is  $C_a > 0$  such that

$$\begin{aligned} I(s) &= |a(\tau_0\|u_x(s)\|^2 + (1-\tau_0)\|\phi_x\|^2) - a(\tau_n\|(u_n)_x(s)\|^2 + (1-\tau_n)\|\phi_x\|^2)| \\ &\leq C_a |\tau_0\|u_x(s)\|^2 - \tau_n\|(u_n)_x(s)\|^2 + (\tau_n - \tau_0)\|\phi_x\|^2| \\ &\leq C_a |\tau_0 - \tau_n| (\|u_x(s)\|^2 + \|\phi_x\|^2) + \tau_n\|(u_n)_x(s) - u_x(s)\|^2. \end{aligned}$$

Thus, for some constant  $C > 0$ ,

$$\left\| \frac{f(u_n(s))}{a_{\tau_n}(\|(u_n)_x(s)\|^2)} - \frac{f(u(s))}{a_{\tau_0}(\|u_x(s)\|^2)} \right\| \leq C \left[ \|u_n(s) - u(s)\|_{H_0^1(0,\pi)} + |\tau_n - \tau_0| \right].$$

Finally, using that  $X^{\frac{1}{2}} = H_0^1(0,\pi)$  and (2.2), we have

$$\begin{aligned} \|u_n(r) - u(r)\|_{H_0^1(0,\pi)} &\leq \|e^{Ar}(u_0^{(n)} - u_0)\|_{H_0^1(0,\pi)} \\ &\quad + \int_0^r \left\| e^{A(r-s)} \left[ \frac{f(u_n(s))}{a_{\tau_n}(\|(u_n)_x(s)\|^2)} - \frac{f(u(s))}{a_{\tau_0}(\|u_x(s)\|^2)} \right] \right\|_{H_0^1(0,\pi)} ds \\ &\leq e^{-r} \|u_0^{(n)} - u_0\|_{H_0^1(0,\pi)} + C |\tau_n - \tau_0| \int_0^r e^{-(r-s)} (r-s)^{-\frac{1}{2}} ds \\ &\quad + \int_0^r C e^{-(r-s)} (r-s)^{-\frac{1}{2}} \|u_n(s) - u(s)\|_{H_0^1(0,\pi)} ds. \end{aligned}$$

Taking  $\psi(s) = e^s \|u_n(s) - u(s)\|_{H_0^1(0,\pi)}$ , we find

$$\psi(r) \leq a + \int_0^r C(r-s)^{-\frac{1}{2}} \psi(s) ds,$$

for  $a^n = \|u_0^{(n)} - u_0\|_{H_0^1(0,\pi)} + Ce^T |\tau_n - \tau_0| \Gamma(\frac{1}{2})$ , where  $\Gamma(\cdot)$  represents the Gamma function. By (CARVALHO; LANGA; ROBINSON, 2013, Lemma 6.24), taking  $K = (2C\Gamma(\frac{1}{2}))^2$ , we have, for all  $r \in [0, T]$ ,

$$\psi(r) \leq 2a^n e^{Kr}.$$

Hence, for all  $r \in [0, T]$ ,

$$\|u_n(r) - u(r)\|_{H_0^1(0, \pi)} \leq 2\bar{C}e^{(K-1)r} \left( \|u_0^{(n)} - u_0\|_{H_0^1(0, \pi)} + e^T |\tau_n - \tau_0| \Gamma\left(\frac{1}{2}\right) \right).$$

Now,

$$\begin{aligned} & \|u_n(t_n) - u(t_0)\|_{H_0^1(0, \pi)} \leq \|u(t_n) - u(t_0)\|_{H_0^1(0, \pi)} + \|u_n(t_n) - u(t_n)\|_{H_0^1(0, \pi)} \\ & \leq \|u(t_n) - u(t_0)\|_{H_0^1(0, \pi)} + 2\bar{C}e^{(K-1)t_n} \|u_0^{(n)} - u_0\|_{H_0^1(0, \pi)} + 2\bar{C}e^{(K-1)t_n} e^T \Gamma\left(\frac{1}{2}\right) |\tau_n - \tau_0|. \end{aligned}$$

By (5.14) and (5.15), it follows that  $\|u_n(t_n) - u(t)\|_{H_0^1(0, \pi)} \rightarrow 0$  as  $n \rightarrow +\infty$ .  $\square$

**Remark 5.6.3.** For  $\lambda > 0$ , lemmas 5.6.1 and 5.6.2 are valid if you assume  $a(\|\phi_x\|^2) = \lambda c(\|\phi_x\|^2)$  and  $a'(\|\phi_x\|^2) > \lambda c'(\|\phi_x\|^2)$ , for all  $\phi \in \mathcal{E}$ .

But this hypothesis is very abstract and not truly applicable.

**Remark 5.6.4.** The assumption of  $f$  being odd is not necessary in the above result.

**Theorem 5.6.5.** Suppose that  $a$  is non-decreasing and  $a(0)N^2 < \lambda < a(0)(N+1)^2$ , for  $N \in \mathbb{N}$ . Under the same notation of Theorem 5.2.6, we have that the Conley index of  $\phi_j^\pm$  of (5.3) is well-defined and  $I(\{\phi_j^+\})$  and  $I(\{\phi_j^-\})$  are pointed  $(j-1)$ -spheres, for  $j = 1, \dots, N$ . Also,  $I(\{0\})$  is a pointed  $N$ -sphere.

*Proof.* Consider the family of semigroups presented in Lemma 5.6.1 and  $j \in \{1, \dots, n\}$ . Just to fix the notation, for each  $\tau \in [0, 1]$ , denote by  $\phi_{j,\tau}^+$  the equilibrium in  $\mathcal{E}^\tau$  satisfying  $\phi_{j,\tau}^+(0) = \phi_{j,\tau}^+(\frac{\pi}{j}) = 0$  and  $\phi_{j,\tau}^+(x) > 0$  in  $(0, \frac{\pi}{j})$ .

Observe that  $\phi_j^\pm = \phi_{j,1}^\pm$ . We will calculate  $I(\{\phi_j^+\})$ , for  $j = 1, \dots, n$ . The cases  $\phi_j^-$  and 0 follow similarly.

Define

$$\begin{aligned} \alpha : [0, 1] & \rightarrow \mathcal{S}(X) \\ \tau & \mapsto \alpha(\tau) = [\{\phi_{j,\tau}^+\}, S_\tau(\cdot)]. \end{aligned}$$

We want to show that  $\alpha$  is  $\mathcal{S}$ -continuous.

For each  $\tau \in [0, 1]$ , consider  $\delta_\tau = \frac{1}{2} \inf\{\|\psi_x - \varphi_x\| : \psi, \varphi \in \mathcal{E}^\tau, \psi \neq \varphi\} > 0$ , which is well-defined since each equilibrium is isolated, for  $\lambda \in (a(0)N^2, a(0)(N+1)^2)$ . Also define, for each  $\tau \in [0, 1]$ ,

$$N_\tau = \{u \in H_0^1(0, \pi) : \|u - \phi_{j,\tau}^+\|_{H_0^1(0, \pi)} \leq \delta_\tau\}$$

and

$$\begin{aligned} V_\tau & = \{(c_\tau, d_\tau) \cap [0, 1] : \tau \in (c_\tau, d_\tau) \cap [0, 1] \text{ and } N_\tau \cap \mathcal{E}^\sigma = \{\phi_{j,\sigma}^+\} \subset \text{int}(N_\tau), \\ & \text{for all } \sigma \in (c_\tau, d_\tau) \cap [0, 1]\}. \end{aligned}$$

The above sets are well-defined, by the continuity of the equilibria in the parameter  $\tau$ , see Lemma 5.6.1. Thus,  $N_\tau$  is an isolating neighborhood of  $\phi_{j,\sigma}^+$ , for all  $\sigma \in V_\tau$ ,  $\tau \in [0, 1]$ . By Lemma 5.6.2, it only remains to show that  $N_\tau$  is admissible for every convergent sequence  $\{\tau_n\}_{n \in \mathbb{N}} \in V_\tau$  in the sense of Definition 2.1.25, point ii), for all  $\tau \in [0, 1]$ .

Consider sequences  $\{\tau_n\}_{n \in \mathbb{N}} \in [0, 1]$  with  $\tau_n \rightarrow \tau_0$  and  $\{t_n\}_{n \in \mathbb{N}} \subset \mathbb{R}^+$  such that  $t_n \rightarrow +\infty$ . Suppose that, for each  $n \in \mathbb{N}$ , we find a solution  $\psi_n : \mathbb{R}^+ \rightarrow X$  of  $\{S_{\tau_n}(t) : t \geq 0\}$  satisfying  $\psi_n([0, t_n]) \subset N_{\tau_0}$ . We want to prove that  $\{\psi_n(t_n)\}_{n \in \mathbb{N}}$  is a convergent subsequence.

For each  $n \in \mathbb{N}$ , we make the change of variable in order to find a solution  $w_n(\alpha_n(t)) = \psi_n(t)$  of (5.3), where  $\alpha_n(t) = \int_0^t a_{\tau_n}(\|\psi_n\|_x(r))^2 dr$ , for  $t \in [0, t_n]$ . The function  $\alpha_n$  depends on  $\psi_n$  and  $\alpha_n(0) = 0$ , for  $n \in \mathbb{N}$ . Thus,  $w_n([0, \alpha_n(t_n)]) \subset N_{\tau_0}$ . By the formula of variation of constants,

$$w_n(\alpha_n(t_n)) = e^{A\alpha_n(t_n)} \psi_n(0) + \int_0^{\alpha_n(t_n)} e^{-A(\alpha_n(t_n)-s)} \frac{\lambda f(w_n(s))}{a_{\tau_n}(\|(w_n)_x(s)\|^2)} ds.$$

Then, for  $\gamma \in (\frac{1}{2}, 1]$ , we get

$$\begin{aligned} \|w_n(\alpha_n(t_n))\|_{X^\gamma} &\leq \|e^{A\alpha_n(t_n)} \psi_n(0)\|_{X^\gamma} + \int_0^{\alpha_n(t_n)} \frac{\lambda \|e^{A[\alpha_n(t_n)-s]} f(w_n(s))\|_{X^\gamma}}{a_{\tau_n}(\|(w_n)_x(s)\|^2)} ds \\ &\leq [\alpha_n(t_n)]^{\frac{1}{2}-\gamma} \|(\psi_n)_x(0)\| + \int_0^{\alpha_n(t_n)} \frac{\lambda [\alpha_n(t_n)-s]^{-\gamma}}{a_{\tau_n}(\|w_x(s)\|^2)} e^{-(\alpha_n(t_n)-s)} \|f(w_n(s))\| ds. \end{aligned}$$

Using that  $f$  is continuous,  $m \leq a_{\tau_n}(t)$ , for all  $t \in \mathbb{R}$ , and  $H_0^1(0, \pi) \subset L^\infty(0, \pi)$ , we find a constant  $C > 0$  such that

$$\begin{aligned} \|w(\alpha_n(t_n))\|_{X^\gamma} &\leq \alpha_n(t_n)^{\frac{1}{2}-\gamma} \delta + \frac{C}{m} \int_0^{\alpha_n(t_n)} e^{-(\alpha_n(t_n)-s)} [\alpha_n(t_n)-s]^{\frac{1}{2}-\gamma} ds \\ &\leq \alpha_n(t_n)^{\frac{1}{2}-\gamma} \delta + \frac{C}{m} \int_0^{+\infty} e^{-\tau} \tau^{\frac{1}{2}-\gamma} d\tau. \end{aligned}$$

Since  $\gamma - \frac{1}{2} > 0$ , we find  $\tilde{M} > 0$  such that

$$\|w(\alpha_n(t_n))\|_{X^\gamma} \leq \tilde{M}, \quad (5.16)$$

for all  $n \in \mathbb{N}$ . Therefore, the sequence  $\{w(\alpha_n(t_n)) = \psi(t_n)\}_{n \in \mathbb{N}}$  is pre-compact in  $H_0^1(0, \pi)$ . Now,  $\psi(t_n) \in N_{\tau_0}$ , for all  $n \in \mathbb{N}$ , and  $N_{\tau_0}$  is closed, so we find a subsequence of  $\{\psi(t_n)\}_{n \in \mathbb{N}}$  which is convergent to some point in  $N_{\tau_0}$ .

Therefore,  $\alpha$  is  $S$ -continuous.

Using Theorem 2.1.27, for  $\tau = 0$ , we conclude that, for  $\lambda \in (a(0)N^2, a(0)(N+1)^2)$ ,  $I(\{0\})$  is a pointed  $N$ -sphere and  $I(\{\phi_j^+\})$  and  $I(\{\phi_j^-\})$  are pointed  $(j-1)$ -spheres, for  $j = 1, \dots, N$ .  $\square$

**Proposition 5.6.6.** The semigroup associated to (5.1) restricted to its global attractor  $\mathcal{A}$  is injective. In other words, if  $u : \mathbb{R} \rightarrow H_0^1(0, \pi)$  and  $v : \mathbb{R} \rightarrow H_0^1(0, \pi)$  are global solutions of (5.1) with  $u(\mathbb{R}) \cap v(\mathbb{R}) \neq \emptyset$ , then  $u(\mathbb{R}) = v(\mathbb{R})$ .

*Proof.* Suppose that we find global bounded solutions  $\bar{u}$  and  $\bar{v}$  with  $\bar{u}(\mathbb{R}) \cap \bar{v}(\mathbb{R}) \neq \emptyset$ .

By (CABALLERO *et al.*, 2021) and (CARVALHO; MOREIRA, 2021), applying a change of variable, we find  $u : \mathbb{R} \rightarrow H_0^1(0, \pi)$  and  $v : \mathbb{R} \rightarrow H_0^1(0, \pi)$  which are solutions of (5.3) related, respectively, to  $\bar{u}$  and  $\bar{v}$ . By construction,  $u(\mathbb{R}) \cap v(\mathbb{R}) \neq \emptyset$ . Without loss of generality, we may assume that  $u(T) = v(T)$ , for some  $T \in \mathbb{R}$ .

Define  $w : \mathbb{R} \rightarrow H_0^1(0, \pi)$  as  $w(t) = u(t) - v(t)$ , for  $t \in \mathbb{R}$ . Our goal is to prove that  $w(t) = 0$ , for all  $t \in \mathbb{R}$ . Suppose, by contradiction, that we can find  $t_0 \in \mathbb{R}$  for which  $w(t_0) \neq 0$ . Now,  $w$  satisfies

$$w_t = w_{xx} + h(t), \quad (5.17)$$

where  $h(t) = \lambda \left[ \frac{f(u)}{a(\|u_x\|^2)} - \frac{f(v)}{a(\|v_x\|^2)} \right]$ . Observe that

$$\|h(t)\| \leq \frac{\lambda}{m^2} \left\| [a(\|v_x\|^2) - a(\|u_x\|^2)]f(u) + a(\|u_x\|^2)[f(u) - f(v)] \right\| \leq C\|w_x\|, \quad (5.18)$$

for some constant  $C > 0$ . Hence,  $h(t) \in L^2(0, \pi)$ , for all  $t \in \mathbb{R}$ . By the variation of constants formula, we can see that the problem is locally well-posed. In particular, we find

$$t_1 = \sup\{t \in [t_0, T] : w(s) \neq 0 \text{ for } s \in [t_0, t]\},$$

with  $t_1 > t_0$  and  $w(t_1) = 0$ .

For  $t \in [t_0, t_1)$ , define the functions  $\Gamma(t) = \frac{\|w_x(t)\|^2}{\|w(t)\|^2}$  and  $g(t) = \log \|w(t)\|^{-1}$ . Then

$$\begin{aligned} \frac{1}{2} \frac{d}{dt} \Gamma(t) &= \frac{\langle (w_t)_x, w_x \rangle}{\|w\|^2} - \frac{\|w_x\|^2}{\|w\|^4} \langle w_t, w \rangle = \frac{\langle w_t, -w_{xx} - \Gamma(t)w \rangle}{\|w\|^2} \\ &= \frac{\langle w_{xx} + \Gamma(t)w, -w_{xx} - \Gamma(t)w \rangle}{\|w\|^2} + \frac{\langle h - \Gamma(t)w, -w_{xx} - \Gamma(t)w \rangle}{\|w\|^2} \\ &= -\frac{\|w_{xx} + \Gamma(t)w\|^2}{\|w\|^2} + \frac{\langle h, -w_{xx} - \Gamma(t)w \rangle}{\|w\|^2} \\ &\leq -\frac{1}{2} \frac{\|w_{xx} + \Gamma(t)w\|^2}{\|w\|^2} + \frac{1}{2} \frac{\|h\|^2}{\|w\|^2} \leq C\Gamma(t). \end{aligned}$$

The last line is obtained by using the Young's inequality. Hence, for all  $t \in [t_0, t_1)$ ,

$$\Gamma(t) \leq \Gamma(t_0) + C(t - t_0).$$

Now, by (5.18),

$$\frac{d}{dt} g(t) = -\frac{1}{2} \frac{d}{dt} \log \|w\|^2 = -\frac{\langle w_t, w \rangle}{\|w\|^2} = -\frac{\langle w_{xx}, w \rangle}{\|w\|^2} - \frac{\langle h, w \rangle}{\|w\|^2} \leq \Gamma(t) + C\Gamma^{\frac{1}{2}}(t) \leq 2\Gamma(t) + C^2.$$

Thus, for all  $t \in [t_0, t_1)$ ,

$$\log \|w(t)\|^{-1} \leq \log \|w(t_0)\|^{-1} + [2\Gamma(t_0) + C^2](t - t_0) + C(t - t_0)^2 < \infty.$$

We have shown that  $g$  is uniformly bounded in  $[t_0, t_1)$ , which is a contradiction with  $w(t_1) = 0$ . The contradiction comes from assuming that we find  $t_0 \in \mathbb{R}$  such that  $w(t_0) \neq 0$ .

Therefore,  $u(t) = v(t)$ , for all  $t \in \mathbb{R}$ , hence  $\bar{u}(\mathbb{R}) = u(\mathbb{R}) = v(\mathbb{R}) = \bar{v}(\mathbb{R})$ , as desired.  $\square$

Observe that the semigroup associated to (5.3) is also injective restricted to its global attractor.

**Lemma 5.6.7.** Suppose that  $a(\cdot)$  is increasing. Then there cannot be an heteroclinic connection between the equilibria  $\phi_j^+$  and  $\phi_j^-$  of (5.3), for  $j = 1, \dots, n$ .

*Proof.* The proof follows similarly to the last part of the proof of Lemma (3.2.3).  $\square$

**Remark 5.6.8.** The same arguments can be applied, in the case of  $a(\cdot)$  being not necessarily increasing, to prove that there not exist a connection between two equilibria  $\phi$  and  $\psi$  of (5.3) with the same number of zeros in  $[0, \pi]$  and for which  $\phi'(0)\psi'(0) < 0$ . The last assumption is essential. That means, if  $\phi'(0)\psi'(0) > 0$ , then there may exist a connection between  $\phi$  and  $\psi$ .

The proof of Lemma 5.6.7 is also valid if we use the conditions on  $f$  and  $a$  given in (CABALLERO *et al.*, 2021), because Lemma (3.2.1) is valid for non-classical solutions as well (see (CABALLERO *et al.*, 2021, Theorem A3)).

In what follows, we will show that the properties (A1)-(A4) described in Section 3.3 are valid for (5.3), when we assume that  $a(\cdot)$  is increasing and  $f$  is odd. Consequently, the attractor of (5.1) can be well-described and it will have the same structure of the attractor of the Chafee-Infante problem. For convenience, we will study the semilinear problem (5.3), since its global attractor is also the global attractor for (5.1).

Consider the sequence  $\{\lambda_n\}_{n \in \mathbb{N}}$  given by  $\lambda_n = a(0)n^2$ ,  $n \in \mathbb{N}$ . Suppose that  $a(0)n^2 < \lambda < a(0)(n+1)^2$ ,  $n \in \mathbb{N}$ . We define the set

$$\mathcal{M} = \{M(j^i) : j = 0, \dots, N; i \in \{-, +\}\} \cup \{M(n)\}, \quad (5.19)$$

where  $M(n) = \{0\}$  and  $M(j^+) = \{\phi_{j+1}^+\}$  and  $M(j^-) = \{\phi_{j+1}^-\}$ , for  $j = 0, \dots, n-1$ . Although the Morse decomposition (5.19) depends on the parameter  $\lambda$ , we made the choice of simplifying the notation and not explicitly this dependency.

Observe that, for each  $\lambda \in (a(0)n^2, a(0)(n+1)^2)$ ,  $n \in \mathbb{N}$ , and  $\tau \in [0, 1]$ , the semigroup  $\{S_\tau(t) : t \geq 0\}$  associated to (5.13) admits a global attractor, which we will denote by  $\mathcal{A}^\tau$ . Again, we omit the dependence of  $\lambda$  in the notation. Additionally, for  $\tau \in [0, 1]$ , we can apply

Proposition 5.6.6, to  $a_\tau(\cdot)$  instead of  $a(\cdot)$ , and obtain that the semigroup  $\{S_\tau(t) : t \geq 0\}$  restricted to its global attractor defines the flow

$$\varphi_\tau : \mathbb{R} \times \mathcal{A}^\tau \rightarrow \mathcal{A}^\tau.$$

This shows that property **(A1)** is satisfied, for all  $\tau \in [0, 1]$ , where  $\{\lambda_n\}_{n \in \mathbb{N}}$  given by  $\lambda_n = a(0)n^2$ ,  $n \in \mathbb{N}$ .

**Lemma 5.6.9.** The family  $\{\mathcal{A}^\tau : \tau \in [0, 1]\}$  is upper semicontinuous.

*Proof.* It is not difficult to see that  $\bigcup_{\tau \in [0, 1]} \mathcal{A}^\tau$  is a bounded set in  $X^\gamma$ , for some  $\gamma \in (\frac{1}{2}, 1]$ . This follows by the same reasoning applied to obtain (5.16) together with the non-degeneracy of  $a(\cdot)$  and the dissipativity condition (3.2). Hence,

$$\overline{\bigcup_{\tau \in [0, 1]} \mathcal{A}^\tau} \text{ is compact in } H_0^1(0, \pi).$$

Now, the family of semigroups  $\{S_\tau(t) : t \geq 0\}$ ,  $\tau \in [0, 1]$ , is continuous in the sense of Lemma 5.6.2. Finally, we apply Theorem 2.1.15 to obtain the upper semicontinuity of the global attractors.  $\square$

The result below shows that the property **(A2)** is also valid.

**Lemma 5.6.10.** For any  $a(0)N^2 < \lambda < a(0)(N+1)^2$ ,  $N \in \mathbb{N}$ ,  $\mathcal{M}$  is a Morse decomposition. Moreover,

$$\begin{aligned} j^\pm < k^\pm \text{ for } j, k \in \{0, \dots, N-1\} &\iff j < k \text{ in } \mathbb{N}, \\ j^\pm < N, \text{ for all } j \in \{0, \dots, N-1\}. \end{aligned}$$

is an admissible order.

*Proof.* By Lemma 5.6.7, there cannot exist connections between equilibria with the same number of zeros. Now, suppose that we have  $M(k^{\tilde{i}})$  and  $M(j^i)$ , for  $k, j \in \{0, \dots, (N-1), N\}$ ,  $i, \tilde{i} \in \{\emptyset, +, -\}$  and a global solution  $\xi : \mathbb{R} \rightarrow X$  satisfying

$$M(k^{\tilde{i}}) \xrightarrow[t \rightarrow -\infty]{} \xi(t) \xrightarrow[t \rightarrow +\infty]{} M(j^i).$$

The solution  $\xi$  is called a connection from  $M(k^{\tilde{i}})$  to  $M(j^i)$ . We denote by  $C(M(k^{\tilde{i}}), M(j^i))$  the set of all connections from  $M(k^{\tilde{i}})$  to  $M(j^i)$ .

By Lemma 3.2.1, we have  $k \geq j$ . Now, Lemma 5.6.7 excludes the case  $k = j$ . It follows that  $k > j$ , as desired.

Therefore,  $\mathcal{M}$  is a Morse decomposition and the described order is admissible.  $\square$

Property (A3) is a consequence of Theorem 5.6.5. The prove of property (A4) for (5.3) is made using a ‘transition’ that relates such problem to a Chafee-Infante problem (which satisfies (A4), see Section 3.3). Before we proceed, we will present tools that allow us to pass information ‘from one problem to another’. We will present results and definitions from (FRANZOSA, 1988), in our context. For more details and a more general approach, we recommend the cited reference.

Define  $\mathcal{I} = \{I \subset X : I \text{ is an isolated invariant set of } S_\tau(\cdot), \text{ for some } \tau \in [0, 1]\}$ .

Given a compact  $N \subset \mathcal{A}_{[0,1]} := \bigcup_{\tau \in [0,1]} \mathcal{A}^\tau$ , we may associate the maps

$$\Lambda(N) = \{\tau \in [0, 1] : N \text{ is an isolating neighborhood in } \mathcal{A}^\tau\}$$

and  $\sigma_N : \Lambda(N) \rightarrow \mathcal{I}$  given by  $\sigma_N(\tau) = S_\tau$ , where  $S_\tau$  is the largest invariant set of  $S_\tau(\cdot)$  in  $N$ .

It is known, (FRANZOSA, 1988, Proposition 4.4), that  $\mathcal{I}$  is a topological space with the topology generated by the following basis

$$\mathcal{B} = \bigcup_{\substack{N \subset \mathcal{A}_{[0,1]}, \\ N \text{ compact}}} \{\sigma_N(U) \subset X : U \text{ is an open set with } U \subset \Lambda(N)\}.$$

Define the sets

$$\mathcal{M}_P = \bigcup_{\tau \in [0,1]} \{(\mathcal{M}^\tau, \mathcal{A}^\tau) : \mathcal{M}^\tau = \{M^\tau(\pi) : \pi \in P\} \text{ is a Morse decomposition of } \mathcal{A}^\tau\},$$

$$\mathcal{M}_< = \{(\mathcal{M}, \mathcal{A}) \in \mathcal{M}_P : \text{if } \mathcal{M} = \{M(\pi) : \pi \in P\} \text{ and, for } \pi, \pi' \in P, \text{ there is } \gamma \in C(M(\pi), M(\pi')), \text{ then } \pi' < \pi\},$$

where  $<$  represents any partial order in  $P$ .

Thus,  $\mathcal{M}_P$  and  $\mathcal{M}_<$  are topological spaces with the topology induced as subspaces of  $(\prod_{\pi \in P} \mathcal{I}) \times \mathcal{I}$ .

**Definition 5.6.11.** The collection  $\mathcal{M} = \{M(\pi)\}_{\pi \in P}$  is called a  $<$ -ordered Morse decomposition of  $\mathcal{A}$  if  $(\mathcal{M}, \mathcal{A}) \in \mathcal{M}_P$  and if  $\gamma \in \mathcal{A} \setminus \bigcup_{\pi \in P} M(\pi)$ , then there is  $\pi < \pi'$  with  $\gamma \in C(M(\pi'), M(\pi))$ .

**Definition 5.6.12.** Let  $\mathcal{M}^\tau = \{M^\tau(\pi)\}_{\pi \in P}$  and  $\mathcal{M}^{\tilde{\tau}} = \{M^{\tilde{\tau}}(\pi)\}_{\pi \in P}$  be Morse decompositions of  $\mathcal{A}^\tau$  and  $\mathcal{A}^{\tilde{\tau}}$ , respectively.

We say that  $M^\tau$  and  $M^{\tilde{\tau}}$  are related by continuation or are continuations of each other if there is a path  $c$  in  $\mathcal{M}_P$  from  $\prod_{\pi \in P} M^\tau(\pi) \times \mathcal{A}^\tau$  to  $\prod_{\pi \in P} M^{\tilde{\tau}}(\pi) \times \mathcal{A}^{\tilde{\tau}}$ . If, furthermore,  $M^\tau$  and  $M^{\tilde{\tau}}$  are  $<$ -ordered and the path  $c$  is in  $\mathcal{M}_<$ , then we say that the associated admissible orderings are related by continuation or are continuations of each other.

**Theorem 5.6.13** (Corollary 5.6, (FRANZOSA, 1988)). If the flow ordering of  $\mathcal{M}$  is related by continuation to an admissible ordering of  $\tilde{\mathcal{M}}$  then the set of connection matrices of  $\tilde{\mathcal{M}}$  is a subset of the set of connection matrices of  $\mathcal{M}$ .

Fix  $\lambda \in \left(a(0)N^2, a(0)(N+1)^2\right)$ ,  $N \in \mathbb{N}$ , and let  $\{S_\tau(t) : t \geq 0\}$ ,  $\tau \in [0, 1]$ , be the family of semigroups from Lemma 5.6.1. Denote

$$\mathcal{E}^\tau = \{0\} \cup \left\{ \phi_{j,\tau}^+, \phi_{j,\tau}^- : j = 1, \dots, N \right\}.$$

By the proof of Theorem 2.1.27, for any  $j = 1, \dots, N$ , we may assume we find a bounded and closed set  $N \subset H_0^1(0, \pi)$ , such that  $N$  is an isolating neighborhood of  $\phi_{j,\tau}^+$ , for all  $\tau \in [0, 1]$ . The proof for equilibria  $\phi_{j,\tau}^-$  and 0 are analogous.

Then  $\mathcal{M}^\tau = \{M^\tau(0^+), M^\tau(0^-), \dots, M^\tau((N-1)^+), M^\tau((N-1)^-), M^\tau(N)\}$  is a Morse decomposition for  $M^\tau(N) = \{0\}$ ,  $M^\tau(j^+) = \{\phi_{j+1,\tau}^+\}$  and  $M^\tau(j^-) = \{\phi_{j+1,\tau}^-\}$  for  $j = 1, \dots, N-1$ . It is clear that property (A3) is satisfied by this family of Morse decomposition by Theorem 5.6.5 applied to (5.3) with  $a(\cdot)$  replaced by  $a_\tau(\cdot)$ ,  $\tau \in [0, 1]$ .

We also have the following result:

**Lemma 5.6.14.** The map

$$\begin{aligned} c : [0, 1] &\rightarrow \mathcal{M}_P \\ \tau &\mapsto c(\tau) = (\mathcal{M}^\tau, \mathcal{A}^\tau) \end{aligned}$$

is a path in  $\mathcal{M}_P$ .

*Proof.* Consider  $\tau_0 \in [0, 1]$  and let  $\mathcal{V} = \left(\prod_{k \in \{0^\pm, \dots, (N-1)^\pm, N\}} V_k\right) \times V_{\tau_0}$  be an open set in  $\mathcal{M}_P$  that contains  $c(\tau_0)$ . Hence, we have

$$M^{\tau_0}(k) \subset V_k, \text{ for all } k = 0^\pm, \dots, (N-1)^\pm, N, \text{ and } \mathcal{A}^{\tau_0} \subset V_{\tau_0}.$$

Since  $\mathcal{B}$  is a basis for  $\mathcal{M}_P$ , we may assume, w.l.g, that we can find compact sets  $N_k, N_{\tau_0} \subset X$  and open sets  $U_k \subset \Lambda(N_k)$ ,  $U_{\tau_0} \subset \Lambda(N_{\tau_0})$  such that  $V_{\tau_0} = \sigma_{N_{\tau_0}}(U_{\tau_0})$  and  $V_k = \sigma_{N_k}(U_k)$ ,  $k = 0^\pm, \dots, (N-1)^\pm, N$ . Take

$$U = U_{\tau_0} \cap U_N \cap \left( \bigcap_{k=0, \dots, (N-1)} U_{k^+} \cap U_{k^-} \right).$$

It is clear that  $U$  is a not empty open set of  $[0, 1]$ , by the continuity of the Morse decomposition and the upper semicontinuity of the family of attractors. Then, for any  $\tau \in U$ ,  $M^\tau(k)$  is the largest invariant set in  $N_k$ ,  $k = 0^\pm, \dots, (N-1)^\pm, N$ , and  $\mathcal{A}^\tau$  is the largest invariant set in  $N_{\tau_0}$ . Hence  $c(\tau) = (\mathcal{M}^\tau, \mathcal{A}^\tau) \in \mathcal{V}$ , for all  $\tau \in U$ .

Therefore,  $c$  is a path in  $\mathcal{M}_P$ . □

**Theorem 5.6.15.** For any  $\lambda \in \left(a(0)N^2, a(0)(N+1)^2\right)$ ,  $N \in \mathbb{N}$ , the connection matrix associated with the Morse decomposition (5.19) is as in property (A4).



*Proof.* Observe that, for  $\tau = 0$ , we have the problem

$$\begin{cases} u_t = \bar{a}u_{xx} + \lambda f(u), & x \in (0, \pi), t > 0, \\ u(t, 0) = u(t, \pi) = 0, & t \geq 0, \\ u(0, \cdot) = u_0 \in H_0^1(0, \pi), \end{cases} \quad (5.20)$$

for some constant  $\bar{a} > 0$  (which is given by  $a(\|(\phi_N^\pm)_x\|^2)$ , under the same notation of Lemma 5.6.1). Since (5.20) is a Chafee-Infante problem, by (HENRY, 1985), the flow ordering  $<_F$  of  $\varphi_0$  is given by

$$\begin{aligned} j^\pm <_F k^\pm \text{ for } j, k \in \{0, \dots, N-1\} &\iff j < k, \\ j^\pm <_F N, \text{ for all } j \in \{0, \dots, N-1\}. \end{aligned} \quad (5.21)$$

By Section 3.3, the only connection matrix when  $\tau = 0$  is given by

$$\Delta = \begin{bmatrix} 0 & D_1 & 0 & \dots & 0 \\ & 0 & D_2 & \ddots & \vdots \\ \vdots & & \ddots & \ddots & 0 \\ & & & 0 & D_n \\ 0 & & & \dots & 0 \end{bmatrix} \quad (5.22)$$

as in (A4).

By Lemmas 5.6.1 and 5.6.10, it follows the continuity of the Morse decomposition. Applying Lemma 5.6.10 to (5.13), we have, for any  $\tau \in [0, 1]$ , the partial order  $<_F$ , given in (5.21),

$$0^+ < 0^- < \dots < (N-1)^+ < (N-1)^- < N$$

and

$$0^- < 0^+ < \dots < (N-1)^- < (N-1)^+ < N$$

is an admissible order for  $\mathcal{M}^\tau$ . Consequently, the order  $<_F$  is also an admissible order for  $\mathcal{M}^\tau$ , for any  $\tau \in [0, 1]$ . Therefore, property (A2) is satisfied. Hence,  $c([0, 1]) \subset \mathcal{M}_{<_F}$ , for the function  $c$  presented in Lemma 5.6.14. Since  $\mathcal{M}_{<_F}$  is open in  $\mathcal{M}_P$  (see (FRANZOSA, 1988, Proposition 4.14)), it follows that  $c$  is also a path in  $\mathcal{M}_{<_F}$ .

By Theorem 5.6.13, for each  $\tau \in [0, 1]$ , the set of connection matrices related to  $\mathcal{M}^\tau$  is unitary, whose element is given in (5.22). Now, we just need to observe that for  $\tau = 1$  problem (5.13) represents (5.1). Therefore, the condition (A4) is satisfied for (5.1), as desired.  $\square$

Thus, for what it was shown in the section, together with Theorem 3.3.1, we conclude the following

**Theorem 5.6.16.** The global attractor  $\mathcal{A}_\lambda$  of (5.1), for  $a(0)N^2 < \lambda < a(0)(N+1)^2$ , has the same structure of the global attractor  $\tilde{\mathcal{A}}_{\frac{\lambda}{a(0)}}$  of (3.1).

*Proof.* Since problem (5.1) satisfies (A1)-(A4), by Theorem 3.3.1, the attractor  $\mathcal{A}_\lambda$  has the same structure of the attractor for (3.10) for  $n = N$ . By (MISCHAIKOW, 1995, Theorem 1.1), this is the same structure of the attractor of (3.1), for  $\lambda \in (N^2, (N+1)^2)$ .  $\square$

Thus, for any global bounded solution  $\xi : \mathbb{R} \rightarrow H_0^1(0, \pi)$  (not in  $\mathcal{E}_\lambda$ ), we find  $\phi_j, \phi_k \in \mathcal{E}_\lambda$ ,  $\phi_j \neq \phi_k$ , such that

$$\phi_j \xleftarrow{t \rightarrow -\infty} \xi(t) \xrightarrow{t \rightarrow +\infty} \phi_k.$$

Also, either  $\phi_j = \{0\}$  or  $\phi_j$  has at least one more zero in  $[0, \pi]$  than  $\phi_k$ , if  $\xi(\cdot)$  is not an equilibrium. If  $\phi_j, \phi_k \in \mathcal{E}_\lambda$  and  $\phi_j$  has at least one more zero in  $[0, \pi]$  than  $\phi_k$  or  $\phi_j = 0$ , then we find a global bounded solution  $\eta : \mathbb{R} \rightarrow H_0^1(0, \pi)$  satisfying

$$\phi_j \xleftarrow{t \rightarrow -\infty} \eta(t) \xrightarrow{t \rightarrow +\infty} \phi_k.$$

## 5.7 Some remarks and further investigations

In (LI *et al.*, 2020), we have constructed the sequence of bifurcation at zero for (5.1), when considering  $a$  being non-decreasing and  $f$  being odd. Under the same assumptions, in (CARVALHO; MOREIRA, 2021), we have shown that all the equilibria are hyperbolic, with the exception of zero on the parameters of the bifurcations. Later, the structure of the attractor was shown to contain the structure of the attractor of the Chafee-Infante problem, see (MOREIRA; VALERO, 2022b).

In (CABALLERO *et al.*, 2021), the authors made the proof of existence of the equilibria of (5.1) dropping the assumption of  $f$  being odd. But their hyperbolicity was not known until recently.

Finally, in (ARRIETA *et al.*, 2022), we have offered a criteria to study the existence of equilibria of (5.1) (when  $a$  is continuous and far from zero) and to study the hyperbolicity of such equilibria (assuming also that  $a$  is differentiable). We can see that we may find cases of that we have a continuum of equilibria depending on the choice of  $a$ .

Studying the attractor of (5.1) cannot be made altogether (without additional assumptions on the behavior of  $a$ ), since we have several types of possible bifurcations of equilibria. It is clear that the lap-number property is always valid, hence the connections must come from an equilibrium  $\phi$  to a  $\psi$ , with  $\phi$  having more or an equal number of zeros of  $\psi$ .

Related to the discussion presented in this Chapter, we consider that (5.1) is very well-understood if  $a$  is non-degenerated. Now, we intend to consider the problem (5.1) assuming that  $a$  might degenerate.

---

## MULTIVALUED PROBLEMS

---

In this chapter, we will present some results on the multivalued setting. Multivalued problems appeared in the literature in the last century, in the scenario of equations for which we do not have uniqueness of solutions of the Cauchy problem.

In the last century, the authors started to create a new approach of seeking properties that are robust under perturbations. In this sense, Conley offered us the concept of Conley's index, a way of studying a neighborhood of isolated invariant sets from a topological point of view. This concept generalizes the concept of Morse index, which can be calculated only when we have a good understanding of the geometric local asymptotic behavior.

The concept of Conley's index appeared in (CONLEY, 1978), where it was defined for compact isolated invariant sets under the action of semiflows defined on locally compact metric spaces. Later, Rybakowski (RYBAKOWSKI, 1987) generalized the concept for semiflows defined on metric spaces which are not necessarily compact. The importance of this topology definition can be measured by the large amount of studies that followed the above references. Just to cite a few of them, this concept was used in applications (see for instance, (RYBAKOWSKI, 1987; MISCHAIKOW, 1995)), it was also defined for flows on Hilbert spaces (see (NADA, a; BŁaSZCZYK; GOŁĘBIEWSKA; RYBICKI, 2017; IZYDOREK *et al.*, 2017)), for non-autonomous semiflows on Banach spaces (JÄNIG, 2019) and also for multivalued semiflows (see (DZEDZEJ; GABOR, 2011; MROZEK, 1990)).

In the theory of Conley's index developed in (RYBAKOWSKI, 1987), the concept of an isolating block plays a fundamental role. This is a neighborhood of an isolated invariant set of special kind, in which the boundaries are completely oriented in some sense, characterizing in this way the stable and unstable subsets.

The concept of hyperbolicity is not clear in the multivalued context. Then we usually do not have clear information about the local properties. For instance, we still have no tools to study the local behavior of multivalued flows near equilibria, we cannot say much about connections

inside the attractor.

As exposed in the previous chapters, one of the subjects studied during the thesis was the topological theory applied to nonlinear dynamical systems. One of the main references was the book of Rybakowski (see (RYBAKOWSKI, 1987)). During its reading we were wondering if we could develop a similar construction of Conley's index applied to the univalued case to construct such a concept in the multivalued case.

There are several steps to construct the Conley's index for a nonempty compact invariant set in (RYBAKOWSKI, 1987). We will summarize the idea in three basic (and large) steps:

1. Construct an isolating block;
2. Show that the isolating block together with its boundary defines an index pair.
3. Define the Conley's index as the topological figure defined by its index pairs.

All these procedures require several constructions, we preferred not to get into details for the sake of simplicity.

Here, we will show that we are able to use a similar construction made by Rybakowski in Step 1. to construct the isolating block for compact isolated sets in the multivalued problems. The construction we will present here appeared first in (MOREIRA; VALERO, 2022a).

The following steps (2. and 3.) were not developed yet. Although we are interested in such steps, there are available in the literature some variations of definitions of Conley's index. So far as we know, we cannot say the same about the isolating block. We have not found any other construction of this nice neighborhood.

We will present here the definition of an isolating block in the univalued sense. In order to do that, we need to present the concept of egress, ingress and bounce-off points of a closed set.

Consider  $X$  a metric space and a semigroup  $\{T(t) : t \geq 0\}$ . Let  $B$  be a closed subset  $X$  and denote its boundary by  $\partial B$  and its interior ( $B \setminus \partial B$ ) by  $int(B)$ .

1.  $x \in \partial B$  is an egress point of  $B$  if, for a solution  $\sigma : [-\varepsilon, +\infty) \rightarrow X$  of  $\{T(t) : t \geq 0\}$ ,  $\varepsilon \geq 0$ ,  $x = \sigma(0)$ , the following hold:

There is  $\varepsilon_2 > 0$  such that  $\sigma((0, \varepsilon_2]) \not\subset B$ .

If  $\varepsilon > 0$  then, for some  $\varepsilon_1 \in (0, \varepsilon)$ ,  $\sigma([- \varepsilon_1, 0)) \subset int(B)$ .

2.  $x \in \partial B$  is an ingress point of  $B$  if, for any solution  $\sigma : [-\varepsilon, +\infty) \rightarrow X$  of  $\{T(t) : t \geq 0\}$ ,  $\varepsilon > 0$ , with  $x = \sigma(0)$ , the following properties hold:

There is  $\varepsilon_2 > 0$  such that  $\sigma((0, \varepsilon_2]) \subset int(B)$ .

If  $\varepsilon > 0$ , then we find  $\varepsilon_1 \in (0, \varepsilon)$ ,  $\sigma([- \varepsilon_1, 0)) \not\subset B$ .

3.  $x \in \partial B$  is an bounce-off point of  $B$  if, for any solution  $\sigma : [-\varepsilon, +\infty) \rightarrow X$ ,  $\varepsilon \geq 0$ , with  $x = \sigma(0)$ , the following properties hold:

There is  $\varepsilon_2 > 0$  such that  $\sigma((0, \varepsilon_2]) \not\subset B$ , for  $t \in (0, \varepsilon_2]$ ;

If  $\varepsilon > 0$ , then for some  $\varepsilon_1 \in (0, \varepsilon)$ ,  $\sigma((0, \varepsilon_1]) \not\subset B$ .

**Definition 6.0.1.** Under the notation above, we say that a closed subset  $B \subset X$  is an isolating block under the action of  $\{T(t) : t \geq 0\}$  if satisfies the following

- (i)  $\partial B$  is the union of the ingress points of  $B$ , the egress points of  $B$  and the bounce-off points of  $B$ .
- (ii) The union of the set of egress points of  $B$  with the set bounce-off points of  $B$  is closed.

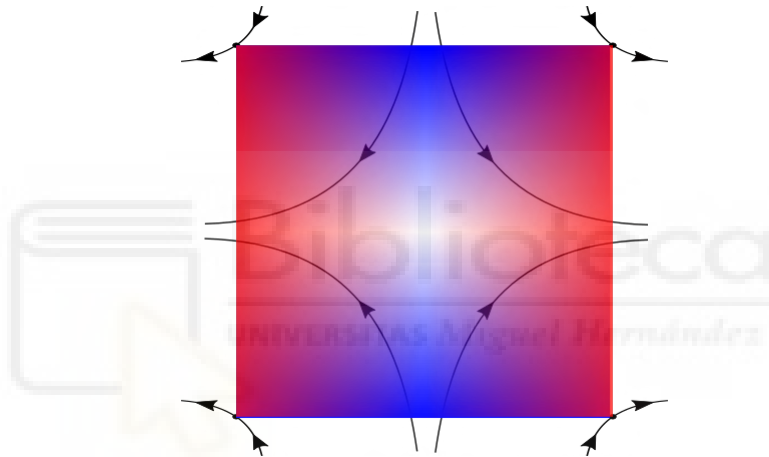

Figure 13 – Isolating block of a saddle-point

Examples of sets that admit an isolating block are the saddle-point equilibria, see Figure 13. The up and down parts on the boundary (in blue) represent the area where we have the ingress points. The left and right parts (in red) on the boundary are the egress points. The vertices of the polygon are the bounce-off points.

In this chapter, we prove the existence of isolating blocks for multivalued semiflows defined on metric spaces under rather general assumptions. This is not a mere generalization, as there are many subtle details that are quite different in the multivalued situation. Later, we apply this result to a differential inclusion generated by reaction-diffusion problems with discontinuous nonlinearities and show that we can construct isolating blocks in each of its non-zero equilibria.

## 6.1 Basic definitions

Let  $(X, d)$  be a metric space and denote  $P(X) = \{B \subset X : B \neq \emptyset\}$ , while  $C(\mathbb{R}^+, X)$  is the set of all continuous functions from  $\mathbb{R}^+$  into  $X$ . Consider a multivalued map  $G : \mathbb{R}^+ \times X \rightarrow P(X)$ , that is, a function that associates each  $(t, x) \in \mathbb{R}^+ \times X$  to the nonempty subset  $G(t, x) \subset X$ .

**Definition 6.1.1.** We say that  $G$  is a multivalued semiflow if:

- i)  $G(0, x) = x$  for all  $x \in X$ ;
- ii)  $G(t + s, x) \subset G(t, G(s, x))$  for all  $x \in X$  and  $t, s \geq 0$ .

The multivalued semiflow is strict if, moreover,  $G(t + s, x) = G(t, G(s, x))$  for all  $x \in X$  and  $t, s \geq 0$ .

A function  $\phi : \mathbb{R} \rightarrow X$  is called a complete trajectory of  $G$  through  $x \in X$ , if  $\phi(0) = x$  and  $\phi(t + s) \in G(t, \phi(s))$ , for all  $t, s \in \mathbb{R}$  with  $t \geq 0$ .

We define  $\mathcal{R} \subset C(\mathbb{R}^+, X)$  to be the set of functions that satisfy the following properties:

- (K1) For any  $x \in X$ , we find  $\phi \in \mathcal{R}$  such that  $\phi(0) = x$ ;
- (K2) Translation property: If  $\phi \in \mathcal{R}$ , then  $\phi_\tau(\cdot) = \phi(\tau + \cdot) \in \mathcal{R}$ , for all  $\tau \in \mathbb{R}^+$ .
- (K3) Concatenation property: Given any  $\phi_1, \phi_2 \in \mathcal{R}$  with  $\phi_1(s) = \phi_2(0)$  for some  $s \geq 0$ , the function  $\phi \in C(\mathbb{R}^+, X)$  given by

$$\phi(t) = \begin{cases} \phi_1(t), & \text{if } t \in [0, s], \\ \phi_2(t - s), & \text{if } t \in (s, +\infty), \end{cases}$$

also belongs to  $\mathcal{R}$ .

- (K4) Let  $\{\phi_n\}_{n \in \mathbb{N}} \subset \mathcal{R}$  be a sequence with  $\phi_n(0) \rightarrow x \in X$ . Then, we find  $\phi \in \mathcal{R}$ ,  $\phi(0) = x$  and such that  $\phi_n \rightarrow \phi$  uniformly on compacts of  $\mathbb{R}^+$ .

The functions from  $\mathcal{R}$  generate the strict multivalued semiflow  $G : \mathbb{R}^+ \times X \rightarrow P(X)$  given by

$$G(t, x) = \{y \in X : y = \phi(t), \phi \in \mathcal{R}, \phi(0) = x\}.$$

The functions  $\phi \in \mathcal{R}$  are called solutions.

**Definition 6.1.2.** A point  $x \in X$  is a fixed point of  $\mathcal{R}$ , if  $\phi \in \mathcal{R}$ , where  $\phi(t) = x$ , for all  $t \geq 0$ .

A function  $\phi : \mathbb{R} \rightarrow X$  is a complete trajectory of  $\mathcal{R}$  if, for any  $\tau \in \mathbb{R}$ ,  $\phi(\tau + \cdot)|_{[0, +\infty)} \in \mathcal{R}$ .

**Remark 6.1.3.** Any complete trajectory of  $\mathcal{R}$  is a complete trajectory of  $G$ . The converse is true when the trajectory is continuous, see (KAPUSTYAN; KASYANOV; VALERO, 2014).

When we are in the multi-valued case, there are many ways of defining invariance.

**Definition 6.1.4.** Consider a set  $A \subset X$ . We say that:

1.  $A$  is invariant if  $G(t, A) = A$ , for all  $t \geq 0$ ;

2.  $A$  is negatively (resp. positively) invariant if  $G(t, A) \subset A$  (resp.  $A \subset G(t, A)$ ), for all  $t \geq 0$ .
3.  $A$  is weakly invariant if, for all  $x \in A$ , we find a complete trajectory  $\phi$  of  $\mathcal{R}$  such that  $\phi(0) = x$  and  $\phi(t) \in A$ , for all  $t \in \mathbb{R}$ .
4.  $A$  is weakly positively invariant if for every  $x \in A$  and  $t \geq 0$  it holds that  $G(t, x) \cap A \neq \emptyset$ .

We will present a list of propositions whose proofs can be found in (COSTA; VALERO, 2017).

**Proposition 6.1.5.** Suppose that conditions (K1) to (K4) are verified. For a closed subset  $A \subset X$ , the following statements are equivalent:

- i)  $A$  is weakly positively invariant;
- ii) For each  $x \in A$ , there is  $\phi \in \mathcal{R}$  with  $\phi(0) = x$  and  $\phi([0, +\infty)) \subset A$ .

**Proposition 6.1.6.** Suppose that conditions (K1) to (K4) are verified. Let  $A \subset X$  be a compact set which is negatively invariant. Then, for each  $x \in A$ , there is a complete trajectory  $\phi$  of  $\mathcal{R}$  with  $\phi(0) = x$  and  $\phi((-\infty, 0]) \subset A$ .

Consider  $B \subset X$  and  $\phi \in \mathcal{R}$ . We define the  $\omega$ -limit set of  $B$  as

$$\omega(B) = \{y \in X : \exists \{t_n\}_{n \in \mathbb{N}} \in \mathbb{R}^+, t_n \rightarrow +\infty \text{ and } \{y_n\}_{n \in \mathbb{N}} \in X, y_n \in G(t_n, B) \text{ and } y_n \rightarrow y\}$$

and the  $\omega$ -limit set of  $\phi$  as

$$\omega(\phi) = \{y \in X : \exists \{t_n\}_{n \in \mathbb{N}} \subset \mathbb{R}^+, t_n \rightarrow +\infty \text{ and } \phi(t_n) \rightarrow y\}.$$

**Definition 6.1.7.** A closed subset  $A \subset X$  is called an isolated weakly invariant set if  $A$  is a weakly invariant set and we find an open neighborhood  $U \subset X$  of  $A$ , such that  $A$  is the maximal weakly invariant set in  $U$ .

Assume (K1)-(K4) and let  $K$  be a closed, isolated and weakly invariant set. Let  $\mathcal{O}(K)$  be an open neighborhood of  $K$ . For any  $\phi \in \mathcal{R}$ ,  $\phi(0) \in \mathcal{O}(K)$ , denote

$$t_\phi = \sup\{t : \phi([0, t]) \subset \mathcal{O}(K)\}.$$

For any  $\phi \in \mathcal{R}$ ,  $\phi(0) = x \in \mathcal{O}(K)$  and sequence  $x_n \rightarrow x$ ,  $\phi_n \in \mathcal{R}$ ,  $\phi_n(0) = x_n \in \mathcal{O}(K)$ , the convergence  $\phi_n \rightarrow \phi$  means that

$$\phi_n(s) \rightarrow \phi(s) \text{ uniformly on } [0, t] \text{ for } t < t_\phi.$$

For what we are going to do, we need to ask an additional assumption for  $\mathcal{R}$ :

(K5) There exists an open neighborhood  $\mathcal{O}(K)$  such that, for any  $x \in \mathcal{O}(K)$  and  $\phi \in \mathcal{R}$ , with  $\phi(0) = x$  and any sequence  $x_n \rightarrow x$  there exists a subsequence  $\phi_{n_k} \in \mathcal{R}$ ,  $\phi_{n_k}(0) = x_{n_k}$  such that  $\phi_{n_k} \rightarrow \phi$  uniformly on compact sets of  $[0, t_\phi)$ .

**Example 6.1.8.** Here is an example of an ordinary differential equation without uniqueness.

Let us consider the equation

$$x' = \sqrt{|x|}. \quad (6.1)$$

The phase space is  $\mathbb{R}$ . For  $x(0) = x_0 > 0$  the unique solution

$$x^+(t) = \left(\frac{t}{2} + \sqrt{x_0}\right)^2, \quad t \geq 0.$$

For  $x(0) = 0$ , we have infinite solutions given by

$$\bar{x}(t) \equiv 0,$$

$$\bar{x}_\tau(t) = \begin{cases} 0, & 0 \leq t \leq \tau, \\ \frac{(t-\tau)^2}{4}, & t \geq \tau, \end{cases}$$

for all  $\tau \geq 0$ . We observe that  $x_0(\cdot)$  is the maximal solution for  $x_0 = 0$  and  $\bar{x}(\cdot)$  is the minimal solution for  $x_0 = 0$ .

Now, for  $x_0 < 0$  the solutions are given by the following

$$x^-(t) = \begin{cases} -\left(-\frac{t}{2} + \sqrt{-x_0}\right)^2, & 0 \leq t \leq 2\sqrt{-x_0}, \\ 0, & t \geq 2\sqrt{-x_0}, \end{cases}$$

$$x^-_\tau(t) = \begin{cases} -\left(-\frac{t}{2} + \sqrt{-x_0}\right)^2, & 0 \leq t \leq 2\sqrt{-x_0}, \\ \bar{x}_\tau(t - 2\sqrt{-x_0}), & t \geq 2\sqrt{-x_0}, \end{cases}.$$

for all  $\tau \geq 0$ .

Now, consider  $x_0 = 0$  and a sequence  $\{x_n\}_{n \in \mathbb{N}} \in \mathbb{R}^+$ . It is clear there only one solution passing through  $x_n$  given by

$$x_n^+(t) = \left(\frac{t}{2} + \sqrt{x_n}\right)^2, \quad t \geq 0, n \in \mathbb{N}.$$

Now, as  $x_n \rightarrow x_0$  as  $n \rightarrow +\infty$ ,

$$x_n^+(t) \rightarrow \frac{t^2}{4}, \quad \text{for all } t \geq 0.$$

Consequently, there is no subsequence of  $\{x_n^+(\cdot)\}_{n \in \mathbb{N}}$  that converges to the solution  $\bar{x}(\cdot)$  on compact subsets of  $\mathbb{R}^+$ .

Therefore, this problem does not satisfy (K5).



### 6.1.1 A differential inclusion with Lipschitz nonlinearity

For a Banach space  $X$  let  $C_v(X)$  be the set of all non-empty, bounded, closed, convex subsets of  $X$ .

Let us consider the boundary-value problem

$$\begin{cases} \frac{\partial u}{\partial t} - \Delta u \in f(u) + q, & \text{on } \Omega \times (0, T), \\ u = 0, & \text{on } \partial\Omega \times (0, T), \\ u(x, 0) = u_0(x) & \text{on } \Omega, \end{cases} \quad (6.2)$$

where  $\Omega \subset \mathbb{R}^n$  is an open bounded set with smooth boundary and  $q \in L^2(\Omega)$ . We assume that the multivalued map  $f$  satisfies the following assumptions:

(f1)  $f : \mathbb{R} \rightarrow C_v(\mathbb{R})$ .

(f2)  $f$  is Lipschitz in the multivalued sense, i.e. there is  $C \geq 0$  such that

$$\text{dist}_H(f(x), f(z)) \leq C|x - z|, \quad \forall x, z \in \mathbb{R}. \quad (6.3)$$

Let us define the multivalued map  $F : D(F) \subset L^2(\Omega) \rightarrow P(L^2(\Omega))$  given by

$$F(y(\cdot)) = \{\xi(\cdot) \in L^2(\Omega) : \xi = \tilde{\xi} + q, \tilde{\xi}(x) \in f(y(x)) \text{ a.e. on } \Omega\}. \quad (6.4)$$

It is known (MELNIK; VALERO, 1998, Lemmas 11, 12) that:

(F1)  $F : L^2(\Omega) \rightarrow C_v(L^2(\Omega))$ ;

(F3)  $F$  is Lipschitz with the same Lipschitz constant as  $f$ , that is,

$$\text{dist}_H(F(u), F(v)) \leq C\|u - v\|_{L^2}, \quad \forall u, v \in L^2(\Omega).$$

The operator  $A = -\Delta : H^2(\Omega) \cap H_0^1(\Omega)$  is maximal monotone in  $L^2(\Omega)$ . Hence, inclusion (6.2) can be written in the abstract form

$$\begin{cases} \frac{du}{dt} + Au \in F(u), & t > 0, \\ u(0) = u_0 \in L^2(\Omega), \end{cases} \quad (6.5)$$

If we assume additionally the existence of  $M \geq 0, \varepsilon > 0$  such that

$$zs \leq (\lambda_1 - \varepsilon)|s|^2 + M, \quad \forall s \in \mathbb{R}, \forall z \in f(s), \quad (6.6)$$

where  $\lambda_1$  is the first eigenvalue of  $-\Delta$  in  $H_0^1(\Omega)$ , then this problem generates a strict multivalued semiflow in  $L^2(\Omega)$  having a global compact attractor  $\mathcal{A}$  (MELNIK; VALERO, 1998).

Let us check that the solutions of (6.5) satisfy property (K5).

The function  $u \in C([0, +\infty), L^2(\Omega))$  is a strong solution of problem (6.5) if there is a selection  $h \in L^2_{loc}(0, +\infty; L^2(\Omega))$ ,  $h(t) \in F(u(t))$  for a.a.  $t$ , such that  $u(\cdot)$  is the unique strong solution of the problem

$$\begin{cases} \frac{du}{dt} + Au = h(t), & t > 0, \\ u(0) = u_0 \in L^2(\Omega), \end{cases} \quad (6.7)$$

which means that  $u(\cdot)$  is absolutely continuous on any compact subset of  $(0, T)$ , it is almost everywhere (a.e.) differentiable on  $(0, T)$ , and  $u(\cdot)$  satisfies the equation in (6.7) a.e. on  $(0, T)$ . Denote the solution of problem (6.7) by  $u(\cdot) = I(u_0)h(\cdot)$ . It is known (BARBU, 1976) that for any  $u_i(\cdot) = I(u_0^i)h_i(\cdot)$ ,  $i = 1, 2$ , the next inequality holds:

$$\|u_1(t) - u_2(t)\|_{L^2} \leq \|u_1(s) - u_2(s)\|_{L^2} + \int_s^t \|h_1(\tau) - h_2(\tau)\|_{L^2} d\tau, \quad t \geq s. \quad (6.8)$$

If we fix  $T > 0$ , it is known (TOLSTONOGOV, 1992) that for any  $z(\cdot) = I(z_0)g(\cdot)$  and any  $u_0 \in L^2(\Omega)$  there exists a solution  $u(\cdot) = I(u_0)h(\cdot)$  of problem (6.5) such that

$$\|u(t) - z(t)\|_{L^2} \leq \xi(t), \quad \forall t \in [0, T], \quad (6.9)$$

$$\|h(t) - g(t)\|_{L^2} \leq \rho(t) + 2C\xi(t), \quad \text{a.e. on } (0, T), \quad (6.10)$$

where

$$\begin{aligned} \rho(t) &= 2 \text{dist}(g(t), F(z(t))), \\ \xi(t) &= \|u_0 - z_0\|_{L^2} \exp(2Ct) + \int_0^t \exp(2C(t-s)) \rho(s) ds. \end{aligned}$$

Concatenating solutions we can easily obtain a solution satisfying these inequalities for any  $T > 0$ .

**Lemma 6.1.9.** Let  $u(\cdot) = I(u_0)h(\cdot)$  be a solution to problem (6.5). Then for any sequence  $u_0^n \rightarrow u_0$  in  $L^2(\Omega)$  there exists a sequence of solutions  $u_n(\cdot) = I(u_0^n)h_n(\cdot)$  of problem (6.5) such that  $u_n \rightarrow u$  in  $C([0, T], L^2(\Omega))$  for every  $T > 0$ .

*Proof.* Since  $h(t) \in F(u(t))$  for a.a.  $t$ , we have

$$\rho(t) = 2 \text{dist}(h(t), F(u(t))) = 0 \quad \text{for a.a. } t,$$

so in view of (6.9) for each  $u_0^n$  there exist solutions  $u_n(\cdot) = I(u_0^n)h_n(\cdot)$  of problem (6.5) such that

$$\|u(t) - u_n(t)\|_{L^2} \leq \|u_0 - u_0^n\|_{L^2} \exp(2Ct), \quad \forall t \geq 0.$$

Then the result follows. □

**Corollary 6.1.10.** Property (K5) is satisfied in  $L^2(\Omega)$ .

**Lemma 6.1.11.** Let  $u(\cdot) = I(u_0)h(\cdot)$  be a solution to problem (6.5) with  $u_0 \in H_0^1(\Omega)$ . Then for any sequence  $u_0^n \rightarrow u_0$  in  $H_0^1(\Omega)$  there exists a sequence of solutions  $u_n(\cdot) = I(u_0^n)h_n(\cdot)$  of problem (6.5) such that  $u_n \rightarrow u$  in  $C([0, T], H_0^1(\Omega))$  for every  $T > 0$ .

*Proof.* From Lemma 6.1.9 we obtain the sequence  $u_n(\cdot) = I(u_0^n)h_n(\cdot)$ . Since  $u_0^n \rightarrow u_0$  in  $H_0^1(\Omega)$  we can prove in a standard way that  $u_n \rightarrow u$  in  $C([0, T], H_0^1(\Omega))$ .  $\square$

**Corollary 6.1.12.** Property (K5) is satisfied in  $H_0^1(\Omega)$ .

## 6.2 Existence of the isolating block in the multivalued case

Given a set  $V \subset X$ , define the sets  $\partial V$ ,  $clV$  and  $intV$  as, respectively, the boundary of  $V$ , the closure of  $V$  and the interior of  $V$ . To be more precise:

$$\begin{aligned} intV &= \{x \in V : \text{there is an open subset } U \subset X \text{ with } x \in U \subset V\}, \\ clV &= \{y \in X : \text{for all open subset } U \subset X, \text{ with } y \in U, U \cap V \neq \emptyset\}, \\ \partial V &= clV \cap cl(X \setminus V). \end{aligned}$$

The definitions that we present below were taken from (RYBAKOWSKI, 1987).

**Definition 6.2.1.** Given a closed isolated invariant set  $A \subset X$ , we say that a closed set  $N \subset X$  is a related isolating neighborhood if  $A \subset int(N)$  (the interior of  $N$ ) and  $A$  is the maximal isolated weakly invariant set in  $N$ .

**Definition 6.2.2.** Let  $B \subset X$  be a closed set and  $x \in \partial B$  be a boundary point. We have the following definitions:

1.  $x$  is an egress point if for every  $\sigma : [-\delta_1, +\infty) \rightarrow X$ ,  $\sigma_{\delta_1} := \sigma(-\delta_1 + \cdot) \in \mathcal{R}$ ,  $x = \sigma(0)$ , with  $\delta_1 \geq 0$ , the following hold:

There is  $\varepsilon_2 > 0$  such that  $\sigma(t) \notin B$ , for  $t \in (0, \varepsilon_2]$ ;

If  $\delta_1 > 0$  then, for some  $\varepsilon_1 \in (0, \delta_1)$ ,  $\sigma(t) \in B$  for  $t \in [-\varepsilon_1, 0)$ .

The set of egress points of  $B$  is denoted by  $B^e$ .

2.  $x$  is an ingress point if for every  $\sigma : [-\delta_1, +\infty) \rightarrow X$ ,  $\sigma_{\delta_1} \in \mathcal{R}$ ,  $x = \sigma(0)$ , with  $\delta_1 \geq 0$ , the following properties hold:

There is  $\varepsilon_2 > 0$  such that  $\sigma(t) \in int(B)$ , for  $t \in (0, \varepsilon_2]$ ;

If  $\delta_1 > 0$  then for some  $\varepsilon_1 \in (0, \delta_1)$ ,  $\sigma(t) \notin B$ , for  $t \in [-\varepsilon_1, 0)$ .

The set of ingress points of  $B$  is denoted by  $B^i$ .

3.  $x$  is an bounce-off point if for every  $\sigma : [-\delta_1, +\infty) \rightarrow X$ ,  $\sigma_{\delta_1} \in \mathcal{R}$ ,  $x = \sigma(0)$ , with  $\delta_1 \geq 0$ , the following properties hold:

There is  $\varepsilon_2 > 0$  such that  $\sigma(t) \notin B$ , for  $t \in (0, \varepsilon_2]$ ;

If  $\delta_1 > 0$  then for some  $\varepsilon_1 \in (0, \delta_1)$ ,  $\sigma(t) \notin B$ , for  $t \in [-\varepsilon_1, 0)$ .

The set of bounce-off points of  $B$  is denoted by  $B^b$ .

We usually denote  $B^- = B^e \cup B^b$  and we call it the exit set of  $B$ .

**Definition 6.2.3.** Let  $K$  be a closed isolated weakly invariant set. An isolating block of  $K$  is a closed set  $B \subset X$  which is an isolating neighborhood of  $K$  with  $\partial B = B^- \cup B^i$  and such that  $B^-$  is closed.

Consider the multivalued semiflows  $\{G_n(t) : t \geq 0\}$ ,  $n \in \mathbb{N}$ , and  $\{G(t) : t \geq 0\}$ , which are generated by the respective sets  $\mathcal{R}_n$ ,  $n \in \mathbb{N}$ , and  $\mathcal{R}$ . Assume that  $K$  is a closed set of  $X$ , which is also an isolated weakly invariant set for the semiflow  $G$ . In this situation, we may ask for additional assumptions.

- (KK4) Let  $\{\phi_n\}_{n \in \mathbb{N}}$  be a sequence with  $\phi_n \in \mathcal{R}_n$ ,  $n \in \mathbb{N}$ , and  $\phi_n(0) \rightarrow x$ , for some  $x \in X$ . Then, we find  $\phi \in \mathcal{R}$ ,  $\phi(0) = x$  and such that  $\phi_n \rightarrow \phi$  uniformly on compacts of  $\mathbb{R}^+$ .
- (KK5) There exists an open neighborhood  $\mathcal{O}(K)$  such that, for any  $x \in \mathcal{O}(K)$  and  $\phi \in \mathcal{R}$ , with  $\phi(0) = x$  and any sequence  $x_n \rightarrow x$  in  $X$ , there exists a subsequence  $\phi_{n_k} \in \mathcal{R}_{n_k}$ ,  $\phi_{n_k}(0) = x_{n_k}$  such that  $\phi_{n_k} \rightarrow \phi$  uniformly on compact sets of  $[0, t_\phi)$ .

Observe that if we consider  $\mathcal{R}_n \equiv \mathcal{R}$ ,  $n \in \mathbb{N}$ , satisfying (KK4) (resp. (KK5)), then  $\mathcal{R}$  satisfies (K4) (resp. (K5)).

**Definition 6.2.4.** A closed set  $N \subset X$  is called  $\{G_n\}$ -admissible if, given sequences  $\{x_n\}_{n \in \mathbb{N}}$ ,  $\{t_n\}_{n \in \mathbb{N}} \in \mathbb{R}^+$ , where  $t_n \rightarrow +\infty$ , and  $\{\phi_n\}_{n \in \mathbb{N}}$  for which  $\phi_n \in \mathcal{R}_n$ ,  $\phi_n(0) = x_n$ ,  $\phi_n([0, t_n]) \subset N$ ,  $n \in \mathbb{N}$ , we have that  $\{\phi_n(t_n)\}_{n \in \mathbb{N}}$  has a convergent subsequence. We say that  $N \subset X$  is  $G$ -admissible if it is  $\{G_n\}$ -admissible, where  $G_n = G$ , for all  $n \in \mathbb{N}$ .

**Remark 6.2.5.** We can change the hypothesis of admissibility of the semiflows by the collectively asymptotic compactness, if we restrict the analysis over bounded isolating neighborhoods  $N$ . In fact, collectively asymptotic compactness is stronger than admissibility.

We recall that  $\{G_n(t) : t \geq 0\}_{n \in \mathbb{N}}$  is collectively asymptotic compact if, given any sequences  $\{t_n\}_{n \in \mathbb{N}}$  and  $\phi_n \in \mathcal{R}_n$ , such that  $\{\phi_n(0)\}_{n \in \mathbb{N}}$  is bounded and  $t_n \rightarrow +\infty$ , we have that  $\{\phi_n(t_n)\}_{n \in \mathbb{N}}$  has a convergent subsequence.

In the multi-valued case, there is the possibility of having more than one solution passing through a point and therefore, we need to adapt the results related to the existence of the isolating block, which are not directly applicable.

In this section, we will follow the construction made by Rybakowski in (RYBAKOWSKI, 1987), with the necessary adaptations, in order to construct the isolating block. This means that, although we do not have uniqueness of solutions, we are still able to construct a closed neighborhood for which its boundary describes the entry and exit directions. This result is our contribution and can be also seen in (MOREIRA; VALERO, 2022a).

Consider  $K$  to be a closed isolated weakly invariant set and  $N$  to be a closed isolating neighborhood of  $K$ . Denote  $U = \text{int}(N)$  and define the sets  $\mathcal{U} = \{\phi \in \mathcal{R} : \phi(0) \in U\}$  and  $\mathcal{N} = \{\phi \in \mathcal{R} : \phi(0) \in N\}$ . Observe that  $\mathcal{U} \subset \mathcal{N}$ .

For the multivalued semiflow  $G$  generated by  $\mathcal{R}$ , we denote by  $A_G^+(N)$  the set of points  $y \in N$  for which we find a  $\phi \in \mathcal{R}$  such that  $\phi([0, +\infty)) \subset N$  and  $\phi(0) = y$ . Also, denote by  $A_G^-(N)$  the set of points  $y \in N$  for which we find a complete trajectory  $\phi$  of  $\mathcal{R}$  such that  $\phi((-\infty, 0]) \subset N$  and  $\phi(0) = y$ . Obviously,  $K \subset A_G^+(N) \cap A_G^-(N)$ . Using (K3), we obtain that the converse is also true, so  $K = A_G^+(N) \cap A_G^-(N)$ .

The following result is analogous to Theorem 4.5 in (RYBAKOWSKI, 1987).

**Proposition 6.2.6.** Let  $N \subset X$  be closed and  $G, G_n$  be multivalued semiflows,  $n \in \mathbb{N}$ . Denote by  $\mathcal{R}_n$  the set of functions related to  $G_n$ ,  $n \in \mathbb{N}$ , and by  $\mathcal{R}$  the set of functions related to  $G$ , that satisfy the properties (K1)-(K4) and collectively satisfy (KK4).

Consider  $x \in X$  and  $\{x_n\}_{n \in \mathbb{N}} \in X$  with  $x_n \rightarrow x$  as  $n \rightarrow +\infty$ . Suppose that, for each  $n \in \mathbb{N}$ , we find  $\phi_n \in \mathcal{R}_n$  and  $t_n \in \mathbb{R}^+$  such that  $\phi_n(0) = x_n$  and  $\phi_n([0, t_n]) \subset N$ . It follows:

- (a1) If  $t_n \rightarrow +\infty$  and  $\phi_n \rightarrow \phi$  uniformly on compact sets of  $\mathbb{R}^+$ , then we find  $\phi \in \mathcal{R}$  with  $\phi(0) = x$  and  $\phi(t) \in N$ , for all  $t \in \mathbb{R}^+$ .
- (a2) If  $t_n \rightarrow t_0$ , for some  $t_0 \in \mathbb{R}^+$ , and  $\phi_n \rightarrow \phi$  uniformly on compact sets of  $\mathbb{R}^+$ , then we find  $\phi \in \mathcal{R}$  with  $\phi(0) = x$  and  $\phi([0, t_0]) \subset N$ .

Assume that  $N$  is  $\{G_{n_m}\}$ -admissible for every subsequence of  $\{G_n\}_{n \in \mathbb{N}}$ . Then,

- (b1) If  $t_n \rightarrow +\infty$  as  $n$  goes to  $+\infty$ , every limit point of  $\{\phi^{(n)}(t_n)\}_{n \in \mathbb{N}}$  belongs to  $A_G^-(N)$ .
- (b2) Denote by  $K_n$  the largest weakly invariant set for  $G_n$  in  $N$ ,  $n \in \mathbb{N}$ . If  $W \subset N$  with  $K \subset \text{int}W$ , then  $K_n \subset \text{int}W$  for  $n$  sufficiently large.
- (b3) If  $N$  is  $G$ -admissible, the sets  $K$  and  $A_G^-(N)$  are compact.

*Proof.* We prove each statement separately.

- (a1) By (KK4), we find a  $\phi \in \mathcal{R}$  such that  $\phi_n \rightarrow \phi$  uniformly on compact sets of  $\mathbb{R}^+$ . By contradiction, suppose that for some  $T > 0$ ,  $\phi(T) \notin N$ . Then we would find a  $\varepsilon > 0$  with  $\mathcal{O}_\varepsilon(\phi(T)) \subset X \setminus N$ , and  $n_0 \in \mathbb{N}$  sufficiently large such that  $\phi_n(T) \in \mathcal{O}_\varepsilon(\phi(T))$ , for all  $n \geq n_0$ . Consequently,  $t_n < T$ , for all  $n \geq n_0$ . This is a contradiction, since  $t_n \rightarrow +\infty$  as  $n$  goes to  $+\infty$ . Therefore, for all  $t \in \mathbb{R}^+$ , we have  $\phi(t) \in N$ .
- (a2) By (KK4), there is a  $\phi \in \mathcal{R}$  for which  $\phi_n \rightarrow \phi$  uniformly on compact sets of  $\mathbb{R}^+$ . For any  $\varepsilon \in (0, t_0)$ , repeating the same argument above taking  $T = t_0 - \varepsilon$ , it follows that  $\phi([0, t_0 - \varepsilon]) \subset N$ . Since  $N$  is closed, we conclude that  $\phi([0, t_0]) \subset N$ .

- (b1) By the admissibility of  $N$ , we find a subsequence  $\{\phi_n^{(0)}(t_n^{(0)})\}_{n \in \mathbb{N}} \subset \{\phi_n(t_n)\}_{n \in \mathbb{N}}$  such that  $\phi_n^{(0)}(t_n^{(0)}) \rightarrow x$  as  $n \rightarrow +\infty$ . We can apply the same arguments for the sequence  $\{\phi_n^{(0)}(t_n^{(0)} - 1)\}_{n \geq n_0}$ , where  $n_0 \in \mathbb{N}$  is such that  $t_n^{(0)} \geq 1$ , for  $n \geq n_0$ . Then, we extract a subsequence  $\{\phi_n^{(1)}(t_n^{(1)} - 1)\}_{n \geq n_0} \subset \{\phi_n^{(0)}(t_n^{(0)} - 1)\}_{n \geq n_0}$  such that  $\phi_n^{(1)}(t_n^{(1)} - 1) \rightarrow y_1 \in N$ . We construct a function  $\psi^{(1)} : [-1, +\infty) \rightarrow X$  with  $\psi^{(1)}(-1) = y_1$  and  $\psi^{(1)}(0) = x$ ,  $\psi^{(1)}(\cdot - 1) \in \mathcal{R}$  and  $\psi^{(1)}([-1, 0]) \subset N$  using the same construction applied in the proof of Lemma 5 from (COSTA; VALERO, 2017).

Applying this argument recursively, for  $k \in \mathbb{N}$ , we find a subsequence

$$\left\{ \phi_n^{(k+1)}(t_n^{(k+1)} - k - 1) \right\}_{n \in \mathbb{N}} \subset \left\{ \phi_n^{(k)}(t_n^{(k)} - k - 1) \right\}_{n \in \mathbb{N}}$$

such that  $\phi_n^{(k+1)}(t_n^{(k+1)} - k - 1) \rightarrow y_{k+1}$  and we use the construction applied in Lemma 5, (COSTA; VALERO, 2017), to construct a connection between  $y_{k+1}$  and  $y_k$  and concatenation to construct  $\psi^{(k+1)} : [-k - 1, +\infty) \rightarrow X$ , with  $\psi^{(k+1)}(\cdot - k - 1) \in \mathcal{R}$  such that  $\psi^{(k+1)}([-k - 1, 0]) \subset N$ ,  $\psi^{(k+1)}(-k - 1) = y_{k+1}$  and  $\psi^{(k+1)}(0) = x$ . Moreover,  $\psi^{(k+1)}(t) = \psi^k(t)$ , for  $t \geq -k$ .

Then we can define  $\psi : \mathbb{R} \rightarrow X$  with  $\psi(t) = \psi^{(k)}(t)$  if  $t \geq -k$ . By construction,  $\psi$  is well-defined,  $\psi(0) = x$  and  $\psi(t) \in N$  for all  $t \in (-\infty, 0]$ . Also,  $\psi$  is a complete trajectory of  $\mathcal{R}$ . Therefore, we conclude that  $x \in A^-(N)$ , as desired.

- (b2) Suppose that we cannot find  $n_0 \in \mathbb{N}$  in those conditions. Then, we can assume, w.l.g., that we find  $x_n \in K_n \cap N \setminus \text{int}W$ , for all  $n \in \mathbb{N}$ . By definition of  $K_n$  and Propositions 6.1.5 and 6.1.6, we find a complete trajectory  $\phi_n : \mathbb{R} \rightarrow X$  of  $\mathcal{R}_n$  with  $\phi_n(0) = x_n$  and  $\phi_n(\mathbb{R}) \subset N$ . Consider the sequence  $\{t_n\}_{n \in \mathbb{N}} \in \mathbb{R}^+$  such that  $t_n \rightarrow +\infty$ . Define  $\psi_n : \mathbb{R}^+ \rightarrow X$  given by  $\psi_n(t) = \phi_n(t - t_n)$ , for all  $t \geq 0$ . By construction,  $\psi_n([0, t_n]) \subset N$  and, by the admissibility, we find that  $\{\psi_n(t_n)\}_{n \in \mathbb{N}} = \{x_n\}_{n \in \mathbb{N}}$  has a convergent subsequence to a point  $x_0 \in A_G^-(N)$ , by (b1).

By (KK4), since  $x_n = \phi_n(0) \rightarrow x_0$ , we may assume that we find a  $\phi \in \mathcal{R}$  such that  $\phi(0) = x_0$  and  $\phi_n(t) \rightarrow \phi(t)$  for all  $t \geq 0$ . Now, since  $\phi_n$  converges to  $\phi$  and  $N$  is closed, we easily obtain that  $\phi(t) \in N$  for all  $t \geq 0$ .

Hence,  $x_0 \in A_G^-(N) \cap A_G^+(N) = K$ . But, at the same time,  $x_n \rightarrow x_0$ ,  $x_0 \in \text{cl}(N \setminus \text{int}W) = N \setminus \text{int}W$ , which is a contradiction, since  $K \subset \text{int}W$ . Therefore,  $K_n \subset \text{int}W$ , for  $n$  sufficiently large.

- (b3) We want to show now that if  $N$  is  $G$ -admissible, then  $A_G^-(N)$  and  $K$  are compact.

Consider  $\{x_n\}_{n \in \mathbb{N}} \in A_G^-(N)$ . Take a sequence  $\{t_n\}_{n \in \mathbb{N}} \in \mathbb{R}^+$  with  $t_n \rightarrow +\infty$  as  $n$  goes to  $+\infty$ . By definition of  $A_G^-(N)$ , for each  $n \in \mathbb{N}$ , we find a complete trajectory  $\psi_n$  in  $\mathcal{R}$  with  $\psi_n((-\infty, 0]) \subset N$  and  $\psi_n(0) = x_n$ . For each  $n \in \mathbb{N}$ , denote  $\xi_n : [0, +\infty) \rightarrow X$  as  $\xi_n(\cdot) = \phi_n|_{[0, +\infty)}(\cdot - t_n) \in \mathcal{R}$ . Then we have that  $\xi_n(t_n) = x_n$  and  $\xi_n([0, t_n]) \subset N$ , for all

$n \in \mathbb{N}$ . The compactness of  $A_G^-(N)$  will follow by applying item (b1) to the sequence  $\{\xi(t_n)\}_{n \in \mathbb{N}}$ , in the particular case  $G_n \equiv G$ ,  $n \in \mathbb{N}$ .

Suppose now that  $\{x_n\}_{n \in \mathbb{N}} \subset K$ . We can assume that  $x_n \rightarrow x \in A_G^-(N)$ , since  $K \subset A_G^-(N)$  and  $A_G^-(N)$  is compact. Our goal is to show that we can find  $\phi \in \mathcal{R}$  such that  $\phi(0) = x$  and  $\phi(t) \in N$ , for all  $t \geq 0$ . We just observe that, for each  $n \in \mathbb{N}$ , we can find  $\phi_n \in \mathcal{R}_n$  such that  $\phi_n(0) = x_n$  and  $\phi_n(\mathbb{R}^+) \subset N$ . Then, by the property (KK4), we find  $\phi \in \mathcal{R}$  such that  $\phi(0) = x$  and  $\phi_n(t) \rightarrow \phi(t)$ , for all  $t \geq 0$ . Since  $N$  is closed, it follows that  $\phi(\mathbb{R}^+) \subset N$ , hence  $x \in A_G^+(N)$ . Therefore,  $x \in K$  and  $K$  is compact. □

Before presenting the main theorem of this section, we need to define auxiliary functions that play an essential role in the definition of the block. So, we will fix a multivalued semiflow  $G$ , the sets  $\emptyset \neq U \subset N$  with  $U = \text{int}N$  and we will denote  $A_G^-(N)$  simply by  $A^-(N)$ . We recall that  $\mathcal{U} = \{\phi \in \mathcal{R} : \phi(0) \in U\}$  and  $\mathcal{N} = \{\phi \in \mathcal{R} : \phi(0) \in N\}$ .

Basically, we will construct two functions, one “identifying” the stable part inside the neighborhood  $N$  and the other “identifying” the unstable part inside the neighborhood  $N$ . For these functions, we will prove results of monotonicity and upper semicontinuity that will be important to characterize the flow behavior close to the invariant set.

Define the functions:

1.  $s^+ : \mathcal{N} \rightarrow \mathbb{R} \cup \{\infty\}$ ,

$$s^+(\phi) = \sup\{t \in \mathbb{R}^+ : \phi([0, t]) \subset N\},$$

2.  $t^+ : \mathcal{U} \rightarrow \mathbb{R} \cup \{\infty\}$ ,

$$t^+(\phi) = \sup\{t \in \mathbb{R}^+ : \phi([0, t]) \subset U\},$$

3.  $F : X \rightarrow [0, 1]$ ,  $F(x) = \min\{1, d(x, A^-(N))\}$ ,

4.  $D : X \rightarrow [0, 1]$ ,  $D(x) = \frac{d(x, K)}{d(x, K) + d(x, X \setminus N)}$ ,

5.  $g^+ : U \rightarrow \mathbb{R}^+$ ,

$$g^+(x) = \inf_{\phi \in \mathcal{U}, \phi(0)=x} \inf \left\{ \frac{D(\phi(t))}{1+t} : 0 \leq t < t^+(\phi) \right\},$$

6.  $g^- : N \rightarrow \mathbb{R}^+$ ,

$$g^-(x) = \sup_{\phi \in \mathcal{N}, \phi(0)=x} \sup \left\{ \alpha(t)F(\phi(t)) : \begin{array}{l} 0 \leq t \leq s^+(\phi), \text{ if } s^+(\phi) < \infty, \\ 0 \leq t < +\infty, \text{ otherwise} \end{array} \right\},$$

where  $\alpha : [0, \infty) \rightarrow [1, 2)$  is a monotone increasing  $C^\infty$ -diffeomorphism.



Observe that the functions  $F$  and  $D$  are continuous since they can be written as compositions of continuous functions. In that situation, we find the following result

**Proposition 6.2.7.** Assume (K1)-(K4). The function  $g^+$  is increasing along solutions as long the orbits are in  $U$ . To be more precise, given  $x, y \in U$ , for which there are  $\varphi \in \mathcal{R}$  and  $t > 0$ , with  $\varphi(0) = x$ ,  $y = \varphi(t)$  and  $\varphi([0, t]) \subset U$ , it follows that  $g^+(x) \leq g^+(y)$ .

Moreover, if  $g^+(x) \neq 0$ , then  $g^+(x) < g^+(y)$ .

*Proof.* Consider  $x, y \in U$  such that there are  $\varphi \in \mathcal{R}$ ,  $t > 0$ , with  $\varphi(0) = x$ ,  $\varphi(t) = y$  and  $\varphi([0, t]) \subset U$ . We want to show that  $g^+(x) \leq g^+(y)$ .

In order to simplify, for any  $\psi \in \mathcal{U}$ , define

$$f^+(\psi) = \inf \left\{ \frac{D(\psi(t))}{1+t} : 0 \leq t < t^+(\psi) \right\}$$

and the sets  $\mathcal{U}_z = \{\phi \in \mathcal{U} : \phi(0) = z\}$ , for  $z = x, y$ . Then, for each  $\phi \in \mathcal{U}_y$  we can define a  $\psi \in \mathcal{U}_x$  as the concatenation of  $\varphi$  and  $\phi$ , which is well-defined by (K3). The set of such functions  $\psi$  will be denoted by  $\mathcal{U}_{xy}$ . We will show that  $f^+(\psi) \leq f^+(\phi)$ . In fact,

$$\begin{aligned} f^+(\psi) &= \inf \left( \left\{ \frac{D(\varphi(s))}{1+s} : s \in [0, t] \right\} \cup \left\{ \frac{D(\phi(s-t))}{1+s} : s \in [t, t^+(\psi)) \right\} \right) \\ &\leq \inf \left\{ \frac{D(\phi(s-t))}{1+s} : s \in [t, t^+(\psi)) \right\} = \inf \left\{ \frac{D(\phi(u))}{1+u+t} : u \in [0, t^+(\phi)) \right\} \leq f^+(\phi), \end{aligned}$$

where we have used that  $t^+(\psi) = t^+(\phi) + t$ , by construction.

Thus

$$g^+(x) = \inf_{\phi \in \mathcal{U}_x} f^+(\phi) \leq \inf_{\psi \in \mathcal{U}_{xy}} f^+(\psi) \leq \inf_{\phi \in \mathcal{U}_y} f^+(\phi) = g^+(y).$$

Now, assume that  $g^+(x) \neq 0$ . So, we find  $\mu > 0$  such that  $f^+(\phi_t) \geq f^+(\phi) \geq \mu$ , where for  $\phi_t(\cdot) = \phi(t + \cdot)$ , for all  $\phi \in \mathcal{U}_x$ . Now, there is  $\tau = \tau(\phi) \geq t$  for which  $f^+(\phi_t) = \frac{D(\phi_t(\tau-t))}{1+(\tau-t)}$ .

Hence,

$$\frac{f^+(\phi_t) - f^+(\phi)}{t} \geq \frac{1}{t} \left( \frac{D(\phi(\tau))}{1+(\tau-t)} - \frac{D(\phi(\tau))}{1+\tau} \right) \geq \frac{D(\phi(\tau))}{(1+\tau)^2} \geq \frac{f^+(\phi)}{1+\tau} \geq \frac{\mu}{1+\tau}.$$

We claim that there is  $\mu_0 > 0$  such that  $\frac{\mu}{1+\tau(\phi)} \geq \mu_0$ , for all  $\phi \in \mathcal{U}_{xy}$ . If this were not true, we would find a sequence  $\phi^{(n)} \in \mathcal{U}_{xy}$  and  $\{\tau_n\}_{n \in \mathbb{N}} \in [t, +\infty)$  with  $\tau_n \rightarrow +\infty$  and such that  $f^+(\phi_t^{(n)}) = \frac{D(\phi_t^{(n)}(\tau_n-t))}{1+(\tau_n-t)}$ . But then we would have

$$0 < g^+(x) \leq g^+(y) = \inf_{\phi \in \mathcal{U}_{xy}} f^+(\phi_t) \leq \inf_{n \in \mathbb{N}} f^+(\phi_t^{(n)}) = \inf_{n \in \mathbb{N}} \frac{D(\phi_t^{(n)}(\tau_n-t))}{1+\tau_n-t} \leq \inf_{n \in \mathbb{N}} \frac{1}{1+\tau_n-t} = 0,$$

which is a contradiction. Therefore, we find  $\mu_0 > 0$  which implies that  $g^+(x) + \mu_0 t \leq g^+(y)$  and, consequently,  $g^+(x) < g^+(y)$ , as desired.  $\square$



The above proposition is the analogous to the item (2) in (RYBAKOWSKI, 1987, Proposition 5.2) in the single-valued case. Further, we will show the monotonicity of  $g^-$ .

**Proposition 6.2.8.** Assume (K1)-(K4). Let the closed set  $N$  be  $G$ -admissible. The function  $g^-$  is decreasing along solutions as long the orbits stay on  $N$ . To be more precise, if  $x, y \in N$  and there are  $\varphi \in \mathcal{R}$  and  $s > 0$ , with  $\varphi(0) = x$ ,  $y = \varphi(s)$  and  $\varphi([0, s]) \subset N$ , then  $g^-(x) \geq g^-(y)$ .

Moreover, if  $g^-(x) \neq 0$ , then  $g^-(x) > g^-(y)$ .

*Proof.* Let  $x, y \in N$ ,  $\varphi \in \mathcal{R}$  and  $s \in \mathbb{R}^+$  be as in the hypothesis. Consider, for any  $\phi \in \mathcal{N}$ ,

$$f^-(\phi) = \sup \left\{ \alpha(t)F(\phi(t)) : \begin{array}{l} 0 \leq t \leq s^+(\phi), \text{ if } s^+(\phi) < \infty, \\ 0 \leq t < +\infty, \text{ otherwise} \end{array} \right\}$$

and the sets  $\mathcal{N}_z = \{\phi \in \mathcal{N} : \phi(0) = z\}$ , for  $z = x, y$ , and  $\mathcal{N}_{xy} = \{\phi \in \mathcal{N} : \phi(0) = x \text{ and } \phi(s) = y\}$ . For each  $\phi \in \mathcal{N}_y$ , by (K3), we can define a  $\psi \in \mathcal{N}_{xy}$  as the concatenation of  $\varphi$  with  $\phi$ . Similarly to what was done to  $f^+$ , it can be proved that  $f^-(\psi) \geq f^-(\phi)$ .

Consequently,

$$g^-(x) = \sup_{\phi \in \mathcal{N}_x} f^-(\phi) \geq \sup_{\psi \in \mathcal{N}_{xy}} f^-(\psi) \geq \sup_{\phi \in \mathcal{N}_y} f^-(\phi) = g^-(y),$$

that is,  $g^-(x) \geq g^-(y)$ .

We want to show that, if  $g^-(x) \neq 0$ , we have  $g^-(y) < g^-(x)$ . By definition,  $g^-(x) = \sup_{\phi \in \mathcal{N}_x} f^-(\phi)$ , which implies that, for at least one  $\phi \in \mathcal{N}_x$ , we have  $f^-(\phi) \neq 0$ . In particular,  $x = \phi(0) \notin A^-(N)$  and  $F(x) > \mu$ , for some  $\mu > 0$ .

In order to obtain the desired result, we will show that there is  $\delta > 0$  such that, for all  $\phi \in \mathcal{N}_x$ , we have  $f^-(\phi) > \delta + f^-(\phi_s)$ . If this can be proved, we may take supremum in both sides and we would find, for  $y = \phi(s)$ ,

$$g^-(x) \geq \sup_{\phi \in \mathcal{N}_{xy}} f^-(\phi) \geq \sup_{\phi \in \mathcal{N}_{xy}} f^-(\phi_s) + \delta = g^-(y) + \delta,$$

which implies  $g^-(x) > g^-(y)$ .

If there does not exist such  $\delta > 0$ , then, for each  $n \in \mathbb{N}$ , we would find  $\phi^{(n)} \in \mathcal{N}_x$  with

$$f^-(\phi^{(n)}) \leq f^-(\phi_s^{(n)}) + \frac{1}{1+n}.$$

By (K4), since  $\{\phi^{(n)}(0) = x\}_{n \in \mathbb{N}}$  is convergent, we may assume  $\phi^{(n)} \rightarrow \phi$  uniformly on compacts of  $\mathbb{R}^+$ , for some  $\phi \in \mathcal{N}_x$ . So, up to a convergent subsequence, we find

$$0 < \mu \leq \beta := \lim_{n \rightarrow +\infty} f^-(\phi^{(n)}) \leq \lim_{n \rightarrow +\infty} f^-(\phi_s^{(n)}).$$

Now, for each  $n \in \mathbb{N}$ , we find  $t_n, r_n, \gamma_n, \eta_n \in \mathbb{R}^+$  such that  $f^-(\phi^{(n)}) = \alpha(t_n)F(\phi^{(n)}(t_n)) + \gamma_n$ ,  $f^-(\phi_s^{(n)}) = \alpha(r_n)F(\phi_s^{(n)}(r_n)) + \eta_n = \alpha(r_n)F(\phi^{(n)}(r_n + s)) + \eta_n$  and  $\gamma_n, \eta_n \rightarrow 0$ . Without

loss of generality, we may assume that  $t_n \rightarrow t_0$  and  $r_n \rightarrow r_0$  as  $n$  goes to  $+\infty$ , for some  $t_0, r_0 \in \mathbb{R}^+ \cup \{+\infty\}$ .

Suppose initially that  $t_n \rightarrow +\infty$  as  $n$  goes to  $+\infty$ . Since  $N$  is admissible and  $\phi^{(n)}([0, t_n]) \subset N$ , by Proposition 6.2.6 we find  $y \in A^-(N)$  such that, up to a subsequence,  $\phi^{(n)}(t_n) \rightarrow y$  as  $n$  goes to  $+\infty$ . Consequently,  $F(\phi^{(n)}(t_n)) \rightarrow F(y) = 0$  and, since  $\alpha(t_n) \rightarrow \bar{\alpha} \leq 2$ , we conclude that  $\beta = 0$ , which is a contradiction.

On the other hand, assume that  $t_n \rightarrow t_0 < +\infty$ . Since  $\beta \neq 0$ , we also have  $r_n \rightarrow r_0 < +\infty$ . It follows that  $\beta = \alpha(t_0)F(\phi(t_0)) \leq \alpha(r_0)F(\phi(r_0 + s))$ .

But now, for any  $n \in \mathbb{N}$ , by definition of  $t_n$ , we have

$$\alpha(r_n + s)F(\phi^{(n)}(r_n + s)) \leq \alpha(t_n)F(\phi^{(n)}(t_n))$$

and, by applying the limit, we find

$$\alpha(r_0 + s)F(\phi(r_0 + s)) \leq \alpha(r_0)F(\phi(r_0 + s)) \implies \alpha(r_0 + s) \leq \alpha(r_0),$$

since  $F(\phi(r_0 + s)) \neq 0$ . This is a contradiction with  $\alpha$  being a strictly increasing function.

Therefore, we can find  $\delta > 0$ , as desired, and the assumption follows.  $\square$

The above result is the analogous of the item (3) in (RYBAKOWSKI, 1987, Proposition 5.2) in the univalued case. Propositions 6.2.7 and 6.2.8 have shown the monotonicity of  $g^\pm$  for points in the same orbit.

The following result describes the role that  $g^+$  and  $g^-$  have on identifying weakly invariant regions.

**Proposition 6.2.9.** Assume (K1)-(K4). Let  $K \neq \emptyset$  be a closed isolated weakly invariant set. Suppose that  $N$  is a closed isolating neighborhood of  $K$ . The following holds:

- i) Consider  $x \in U$ . If  $g^+(x) = 0$ , then  $x \in A^+(N)$ .
- ii) Consider  $x \in N$ . We have that  $g^-(x) = 0$  if, and only if,  $x \in A^-(N)$ .

If  $x \in N$  and  $g^-(x) = 0$ , it follows that  $g^-(y) = 0$  for all values  $y = \phi(t)$ , where  $\phi \in \mathcal{R}$  with  $\phi(0) = x$  and  $t \in [0, s^+(\phi))$ .

*Proof.* Consider  $f^+$  and  $f^-$  as given in the proof of the proposition above.

We first proof item i).

If  $g^+(x) = 0$ , then, for each  $n \in \mathbb{N}$ , we find  $\phi_n \in \mathcal{R}$ , with  $\phi_n(0) = x$  and  $f^+(\phi_n) < \frac{1}{1+n}$ . Consequently, for each  $n \in \mathbb{N}$ , we find  $t_n \in [0, t^+(\phi_n))$  with

$$\frac{D(\phi_n(t_n))}{1+t_n} < \frac{1}{n+1}. \quad (6.11)$$

We may assume, w. l. g., that as  $n$  goes to  $+\infty$ ,  $\phi_n \rightarrow \phi$  uniformly on compact sets of  $\mathbb{R}^+$ , for some  $\phi \in \mathcal{R}$ , with  $\phi(0) = x$ , and  $t_n \rightarrow t_0$ , for some  $t_0 \in \mathbb{R}^+ \cup \{+\infty\}$ . In particular, by Proposition 6.2.6, we find  $\phi([0, t_0)) \subset N$ . Now, if  $t_0 = +\infty$ , then  $x \in A^+(N)$  follows. On the other hand, if  $t_0 < +\infty$ , by (6.11), we have that  $\frac{D(\phi(t_0))}{1+t_0} = 0$ . This means that  $\phi(t_0) \in K$ . In particular, there is  $\psi \in \mathcal{R}$  with  $\psi(0) = \phi(t_0)$  and  $\psi(\mathbb{R}^+) \subset N$ . Consider  $\eta \in \mathcal{R}$ , the concatenation between  $\phi$  and  $\psi$ , which is well-defined by the property (K3). By construction,  $\eta(t) \in N$  for all  $t \geq 0$  and, then,  $x \in A^+(N)$ .

For item ii), suppose first that  $g^-(x) = 0$  for some  $x \in N$ . Hence, for any  $\phi \in \mathcal{R}$ , with  $\phi(0) = x$ , we have  $f^-(\phi) = 0$ . In particular,  $F(x) = 0$ , which implies that  $x \in A^-(N)$ .

Consider now that  $x \in A^-(N)$  and  $\phi \in \mathcal{R}$ , with  $\phi(0) = x$ . Fix  $t \in [0, s^+(\phi))$ , and let  $y = \phi(t)$ . We want to show that  $y \in A^-(N)$ . In fact, since  $x \in A^-(N)$ , there is a complete trajectory  $\psi$  of  $\mathcal{R}$  with  $\psi(0) = x$  and  $\psi((-\infty, 0]) \subset N$ . Using (K2) and (K3), we have the concatenation of  $\psi$  and  $\phi$ , which is denoted by  $\varphi$ , satisfies  $\varphi((-\infty, 0]) \subset N$  with  $\varphi(0) = y$ . Consequently, for any  $y \in \phi([0, s^+(\phi)))$ , we have that  $y \in A^-(N)$  and  $f^-(\phi) = 0$ , since  $t \in [0, s^+(\phi))$  was arbitrary. Therefore,  $g^-(x) = 0$ , by definition.

The second part follows from the above, since we have shown that the points  $y \in N$  such as in the hypothesis are also in  $A^-(N)$ .  $\square$

**Lemma 6.2.10.** Assume (K1) to (K4). Let  $K \neq \emptyset$  be a closed isolated weakly invariant set. Suppose that  $N$  is a closed isolating neighborhood of  $K$  and that  $g^+$  is not lower semicontinuous at  $x \in U = \text{int } N$ . Then we can find sequences  $\{x_n\}_{n \in \mathbb{N}} \in U$ ,  $\{\phi_n\}_{n \in \mathbb{N}} \in \mathcal{R}$ ,  $\{t_n\}_{n \in \mathbb{N}} \in \mathbb{R}^+$  and  $\phi \in \mathcal{U}_x$  satisfying  $x_n \rightarrow x$  and  $\phi_n \rightarrow \phi$ , uniformly on compact sets of  $\mathbb{R}^+$ , as  $n \rightarrow +\infty$  and, for all  $n \in \mathbb{N}$ ,  $\phi_n(0) = x_n$ ,  $t^+(\phi) < t_n < t^+(\phi_n)$  and  $\frac{D(\phi_n(t_n))}{1+t_n} < g^+(x)$ .

*Proof.* If  $g^+$  is not lower semicontinuous at  $x \in U$ , we find  $\mu > 0$  and  $\{x_n\}_{n \in \mathbb{N}} \in U$  with  $g^+(x_n) < \mu < g^+(x)$ , for all  $n \in \mathbb{N}$ , and  $x_n \rightarrow x$  as  $n \rightarrow +\infty$ . Then, for each  $n \in \mathbb{N}$ , we find  $\phi_n \in \mathcal{R}$ ,  $\phi_n(0) = x_n$ , and  $t_n \in (0, t^+(\phi_n))$  such that

$$\frac{D(\phi_n(t_n))}{1+t_n} < \mu.$$

Now, by (K4), we may assume that  $\phi_n \rightarrow \phi$  uniformly on compact sets of  $\mathbb{R}^+$ , for some  $\phi \in \mathcal{U}_x$ . Observe that  $t^+(\phi) < +\infty$ , since  $f^+(\phi) \geq g^+(x) \neq 0$ . Following the proof of Proposition 6.2.6,  $\{t^+(\phi_n)\}_{n \geq n_0}$  is bounded, for  $n_0$  sufficiently large, which assures that the sequence  $\{t_n\}_{n \geq n_0}$  is also bounded. Without loss of generality, we may assume that there is a  $t_0 \in \mathbb{R}^+$  for which  $t_n \rightarrow t_0$  as  $n \rightarrow +\infty$ .

Since  $\frac{D(\phi_n(t_n))}{1+t_n} \rightarrow \frac{D(\phi(t_0))}{1+t_0}$ , as  $n \rightarrow +\infty$ , it follows that  $\frac{D(\phi(t_0))}{1+t_0} \leq \mu$ . Necessarily, we must have  $t_0 > t^+(\phi)$  and then  $t_n > t^+(\phi)$  for  $n$  sufficiently large.

Therefore, we just need to replace  $\{x_n\}_{n \in \mathbb{N}}$ ,  $\{\phi_n\}_{n \in \mathbb{N}}$  and  $\{t_n\}_{n \in \mathbb{N}}$  by proper choices of subsequences and the result follows.  $\square$

Now, we want to show that, if we restrict the domain of these functions to an appropriate neighborhood of  $K$ ,  $g^+$  and  $g^-$  will be continuous functions.

**Proposition 6.2.11.** Assume (K1) to (K4). Let  $K \neq \emptyset$  be a closed isolated weakly invariant set. Suppose  $N$  is a closed  $G$ -admissible isolating neighborhood of  $K$ . The following holds:

- 1) Suppose that we have  $\{\phi_n\}_{n \in \mathbb{N}}, \phi \in \mathcal{R}$  with  $\phi_n \rightarrow \phi$  uniformly on compact sets of  $\mathbb{R}^+$ . If  $t^+(\phi) > \mu$ , for some  $\mu > 0$ , then there is  $n_0 \in \mathbb{N}$  such that  $t^+(\phi_n) > \mu$ , for all  $n \in \mathbb{N}$ ,  $n \geq n_0$ . If  $s^+(\phi) < \tau$ , for some constant  $\tau > 0$ , then there is  $n_0 \in \mathbb{N}$ , such that  $s^+(\phi_n) < \tau$ , for all  $n \in \mathbb{N}$ , with  $n \geq n_0$ .
- 2) Assuming (K5), we can prove that  $g^+$  is upper-semicontinuous in  $U \cap \mathcal{O}(K)$ . Also, the map  $g^+$  is continuous in a neighborhood of  $K$  in  $\mathcal{O}(K) \cap U$ .
- 3) The map  $g^-$  is upper-semicontinuous in  $N$ . Assuming (K5),  $g^-$  is continuous in any neighborhood  $W$  of  $K$  in  $U \cap \mathcal{O}(K)$  for which  $t^+(\phi) = s^+(\phi)$ , for any  $\phi \in \mathcal{U}$  with  $\phi(0) \in W$ .

*Proof.* 1) Since  $\mu < t^+(\phi)$ , we have  $\phi([0, \mu]) \subset U$ . Now,  $U$  is open and, by the uniform convergence of  $\{\phi_n\}_{n \in \mathbb{N}}$ , we find  $n_0 \in \mathbb{N}$ , such that

$$\phi_n([0, \mu]) \subset U, \text{ for all } n \in \mathbb{N}, n \geq n_0.$$

Hence  $\mu < t^+(\phi_n)$ , for all  $n \geq n_0$ . The strict inequality comes from the fact that either  $t^+(\phi_n) = +\infty$  or  $t^+(\phi_n) < +\infty$  and  $\phi_n(t^+(\phi_n)) \in \partial U$ .

For the second part, assume that there is a  $\tau > 0$ , such that  $s^+(\phi) < \tau$ . Then, by definition of  $s^+(\phi)$ , we can find  $T \in (s^+(\phi), \tau)$  for which  $\phi(T) \in X \setminus N$ . The set  $X \setminus N$  is open, since  $N$  is closed. Hence, we find an open set  $W \subset X \setminus N$ , such that  $\phi(T) \in W$ . Since  $\phi_n(T) \rightarrow \phi(T)$  as  $n \rightarrow +\infty$ , we find a  $n_1 \in \mathbb{N}$  for which  $\phi_n(T) \in W$ , for all  $n \geq n_1$ . Therefore,  $s^+(\phi_n) \leq T < \tau$ , for all  $n \geq n_1$ .

- 2) Consider  $x_0 \in \mathcal{O}(K) \cap U$  and  $\mu > g^+(x_0)$ . We want to show that we can find a neighborhood  $W$  of  $x_0$  in  $\mathcal{O}(K) \cap U$  such that, for each  $z \in W$ , we have  $g^+(z) < \mu$ . If this is not true, then we would find a sequence  $\{y_n\}_{n \in \mathbb{N}} \subset \mathcal{O}(K) \cap U$  such that  $y_n \rightarrow x_0$  and  $g^+(y_n) \geq \mu$ .

Consider  $\phi \in \mathcal{R}$ , with  $\phi(0) = x_0$  and  $f^+(\phi) < \mu$ . Using (K5), we find a subsequence  $y_{n_k}$  and  $\phi_k \in \mathcal{R}$ , with  $\phi_k(0) = y_{n_k}$  and  $\phi_k \rightarrow \phi$  uniformly on compact sets of  $\mathbb{R}^+$ . Since  $f^+(\phi) < \mu$ , we find  $t_0 \in \mathbb{R}^+$ ,  $t_0 < t^+(\phi)$  such that  $\frac{D(\phi(t_0))}{1+t_0} < \mu$ . By item 1), there is  $k_0 \in \mathbb{N}$  such that  $t_0 < t^+(\phi_k)$  and  $\frac{D(\phi_k(t_0))}{1+t_0} < \mu$ , for all  $k \geq k_0$ . Hence, for  $k \geq k_0$ , we have

$$\mu \leq g^+(y_{n_k}) \leq f^+(\phi_k) \leq \frac{D(\phi_k(t_0))}{1+t_0} < \mu$$

which is a contradiction. Therefore,  $g^+$  is upper semicontinuous at any  $x_0 \in \mathcal{O}(K) \cap U$ .

We also want to show that there is an open neighborhood  $W$  of  $K$  with  $W \subset \mathcal{O}(K) \cap U$  for which  $g^+$  is lower semicontinuous in  $W$ . In fact, if this result is not true, we find a sequence  $\{x_n\}_{n \in \mathbb{N}} \in \mathcal{O}(K) \cap U$  such that

$$d(x_n, K) \rightarrow 0, \text{ as } n \text{ goes to } +\infty, \quad (6.12)$$

and  $g^+$  is not lower semicontinuous at  $x_n$ , for all  $n \in \mathbb{N}$ . By Proposition 6.2.6, the set  $K$  is compact and we may assume that  $\{x_n\}_{n \in \mathbb{N}}$  converges to some  $x_0 \in K$  as  $n$  goes to  $+\infty$ .

Using the Lemma 6.2.10, for each  $n \in \mathbb{N}$ , we find:

- i) A sequence  $\{x_n^m\}_{m \in \mathbb{N}} \subset \mathcal{O}(K) \cap U$  with  $x_n^m \rightarrow x_n$  as  $m$  goes to  $+\infty$ ;
- ii) A sequence of solutions  $\phi_n^m \in \mathcal{R}$ , with  $\phi_n^m(0) = x_n^m$ ,  $m \in \mathbb{N}$ , and such that  $\phi_n^m \rightarrow \phi_n$ , for some  $\phi_n \in \mathcal{R}$  with  $\phi_n(0) = x_n$ ;
- iii) A sequence  $\{t_n^m\}_{m \in \mathbb{N}} \in \mathbb{R}^+$  with  $t^+(\phi_n) < t_n^m < t^+(\phi_n^m)$  and with  $\frac{D(\phi_n^m(t_n^m))}{1+t_n^m} < g^+(x_n)$ .

For each  $n \in \mathbb{N}$ , we denote  $y_n = x_n^{m_n}$ ,  $t_n = t_n^{m_n}$ ,  $\psi_n = \phi_n^{m_n}$ , for some  $m_n \in \mathbb{N}$  such that

$$d(y_n, x_n) < 2^{-n}, \quad d(\psi_n(t^+(\phi_n)), \partial U) < 2^{-n},$$

$t^+(\phi_n) < t_n < t^+(\psi_n)$  and with

$$\frac{D(\psi_n(t_n))}{1+t_n} < g^+(x_n). \quad (6.13)$$

We will show that  $\{t^+(\phi_n)\}_{n \in \mathbb{N}}$  is bounded, hence  $\phi_n(t^+(\phi_n)) \in \partial U$ ,  $n \in \mathbb{N}$ , and  $\phi_n^m(t^+(\phi_n)) \rightarrow \phi_n(t^+(\phi_n))$  as  $m$  goes to  $+\infty$ .

By contradiction, assume that  $t^+(\phi_n) \rightarrow +\infty$  as  $n \rightarrow +\infty$ .

For all  $n \in \mathbb{N}$ , set  $s_n = \frac{t^+(\phi_n)}{2}$ , and we have  $\phi_n(s_n) \in N$  and  $s_n \rightarrow +\infty$  as  $n$  goes to  $+\infty$ . By the admissibility of  $N$  and Proposition 6.2.6, we may assume that  $\phi_n(s_n)$  converges to some  $y_0 \in A^-(N)$ . On the other hand, by (K4), we may assume that  $\eta_n \in \mathcal{R}$  given by  $\eta_n(\cdot) = \phi_n(s_n + \cdot)$ ,  $n \in \mathbb{N}$ , converges to some  $\eta \in \mathcal{R}$  with  $\eta(0) = y_0$ . Arguing as above, since  $t^+(\eta_n) = s_n \rightarrow +\infty$ , we have  $t^+(\eta) = +\infty$  and  $\eta(\mathbb{R}^+) \subset N$ . Thus  $y_0 \in A^+(N)$ , which implies that  $y_0 \in K$ .

By (6.13) and the definition of  $g^+$  we have, for each  $n \in \mathbb{N}$ ,

$$D(\psi_n(t_n)) < \frac{(1+t_n)D(\phi(s_n))}{1+s_n}. \quad (6.14)$$

Observe that our choice of  $\psi_n$  implies that  $\psi_n([0, t^+(\phi_n)]) \subset N$ , for all  $n \in \mathbb{N}$ , and, since  $N$  is admissible, we may assume that  $\psi_n(t^+(\phi_n)) \rightarrow z_0 \in N$  as  $n$  goes to  $+\infty$ , and  $z_0 \in A^-(N)$ , by Proposition 6.2.6.

Now we have two other possibilities: either  $\{t_n - t^+(\phi_n)\}_{n \in \mathbb{N}}$  is bounded or not.

- Suppose that  $\{t_n - t^+(\phi_n)\}_{n \in \mathbb{N}}$  is bounded and, without loss of generality, we may assume that as  $n$  goes to  $+\infty$ , we have  $t_n - t^+(\phi_n) \rightarrow \tau_0$ , for some  $\tau_0 \in \mathbb{R}^+$ . Then

$$\frac{1 + t_n}{1 + s_n} = \frac{(1 + t^+(\phi_n)) + t_n - t^+(\phi_n)}{1 + \frac{t^+(\phi_n)}{2}}$$

is uniformly bounded for  $n \in \mathbb{N}$ . Observe that  $D(\phi_n(s_n)) \rightarrow D(y_0) = 0$  as  $n \rightarrow +\infty$  and, then, by (6.14),

$$D(\psi_n(t_n)) \rightarrow 0 \text{ as } n \rightarrow +\infty. \quad (6.15)$$

For each  $n \in \mathbb{N}$ , define  $\varphi_n : \mathbb{R}^+ \rightarrow X$  given by  $\varphi_n(\cdot) = \psi_n(t^+(\phi_n) + \cdot)$ , which belongs to  $\mathcal{R}$ , by (K2). By (K4), we may assume that  $\varphi_n \rightarrow \varphi$  uniformly on compact sets of  $\mathbb{R}^+$ , for some  $\varphi \in \mathcal{R}$ , with  $\varphi(0) = z_0$ . As a consequence,  $\psi_n(t_n) = \varphi_n(t_n - t^+(\phi_n)) \rightarrow \varphi(\tau_0)$  as  $n$  goes to  $+\infty$ . Using that  $D$  is continuous and (6.15), we have  $D(\varphi(\tau_0)) = 0$  and, consequently,  $\varphi(\tau_0) \in K$ . Also,  $\varphi([0, \tau_0]) \subset N$ , by  $\varphi_n([0, t_n - t^+(\phi_n)]) \subset N$  and by the argument in Proposition 6.2.6. It is easy to see that  $z_0 \in A^+(N)$ , using property (K3).

Therefore,  $z_0 \in K \cap \partial U = \emptyset$ , which is a contradiction.

- If  $\{t_n - t^+(\phi_n)\}_{n \in \mathbb{N}}$  is unbounded, we may assume that  $t_n - t^+(\phi_n) \rightarrow +\infty$  as  $n \rightarrow +\infty$ . For each  $n \in \mathbb{N}$ , define  $\varphi_n \in \mathcal{R}$  as above, hence  $\varphi_n([0, t_n - t^+(\phi_n)]) \subset N$ . Again, by (K4), we may assume that  $\varphi_n \rightarrow \varphi$  uniformly on compact sets of  $\mathbb{R}^+$ , for some  $\varphi \in \mathcal{R}$ , with  $\varphi(0) = z_0$ . By the arguments in Proposition 6.2.6, we can conclude that  $\varphi(\mathbb{R}^+) \subset N$ . Therefore,  $z_0 \in A^+(N)$  and we arrive at a contradiction since  $z_0 \in A^-(N) \cap \partial U$ .

Thus, the only remaining possibility is that the sequence  $\{t^+(\phi_n)\}_{n \in \mathbb{N}}$  is bounded. Therefore, without loss of generality, we may assume that  $t^+(\phi_n) \rightarrow t_0$ , for some  $t_0 \in \mathbb{R}^+$ .

We can also prove that  $\{t^+(\psi_n)\}_{n \in \mathbb{N}}$  is bounded. In fact, if this is not true, by (K4), we could assume that  $\psi_n \rightarrow \psi$  uniformly on compacts of  $\mathbb{R}^+$ , for  $\psi \in \mathcal{R}$ ,  $\psi(0) = x_0$  and  $t^+(\psi) = +\infty$ , by the argument in Proposition 6.2.6. Since  $x_0 \in K$ ,  $\psi([0, +\infty)) \subset N$ , and  $K$  is the largest weakly invariant set in this neighborhood, we conclude, using (K3), that  $\psi([0, +\infty)) \subset K$ . On the other hand, by the choice of  $y_n \in X$ ,  $n \in \mathbb{N}$ , and the uniform convergence of  $\psi_n$  to  $\psi$ , we find  $\psi(t_0) \in \partial U$ . Hence, we have a contradiction.

Therefore,  $\{t^+(\psi_n)\}_{n \in \mathbb{N}}$  is also bounded and it may be assumed to be convergent to a point  $\bar{t} \in \mathbb{R}^+$ . Since  $t^+(\phi_n) < t^+(\psi_n)$ , for all  $n \in \mathbb{N}$ , we have  $t_0 \leq \bar{t}$ . As a consequence,  $\{t_n\}_{n \in \mathbb{N}}$  is bounded and we may assume  $t_n \rightarrow \tau$ , for some  $\tau \in [t_0, \bar{t}]$ . By (6.12), we have that  $g^+(x_n) \rightarrow 0$  which, together with (6.13), implies  $D(\psi(\tau)) = 0$ .

We will show that  $\psi(t_0) \in A^+(N) \cap A^-(N) = K$ , but  $\psi(t_0) \in \partial U$ , and that will lead us to a contradiction.



It is easy to see that  $\psi(t_0) \in A^-(N)$ , since  $\psi(0) = x_0 \in K \subset A^-(N)$  and  $\psi([0, t_0]) \subset N$ . Also  $\psi(\tau) \in K \subset A^+(N)$ , which means that we find  $\psi_1 \in \mathcal{R}$ ,  $\psi_1(0) = \psi(\tau)$ , and  $\psi_1(\mathbb{R}^+) \subset K$ . Hence, by (K2) and (K3), the map  $\xi : \mathbb{R}^+ \rightarrow X$  given by

$$\xi(t) = \begin{cases} \psi(t_0 + t), & \text{if } t \in [0, \tau - t_0] \\ \psi_1(t - \tau + t_0) & \text{if } t \geq \tau - t_0 \end{cases}$$

belongs to  $\mathcal{R}$ ,  $\xi(0) = \psi(t_0)$  and  $\xi(\mathbb{R}^+) \subset N$ . Consequently,  $\psi(t_0) \in A^+(N)$ . Thus, we have a contradiction.

Therefore, there exists an open neighborhood  $W$  of  $K$  with  $W \subset \mathcal{O}(K) \cap U$  for which the restriction of  $g^+$  to  $W$  is also lower semicontinuous.

- 3) Suppose, by contradiction, that  $g^-$  is not upper semicontinuous in  $N$ . Then, for some  $x_0 \in N$ , we could find  $\mu > 0$  and a sequence  $\{x_n\}_{n \in \mathbb{N}} \in \mathbb{N}$  with  $x_n \rightarrow x_0$  and  $g^-(x_0) < \mu < g^-(x_n)$ , for all  $n \in \mathbb{N}$ .

Then, for each  $n \in \mathbb{N}$ , we find  $\phi_n \in \mathcal{R}$ ,  $\phi_n(0) = x_n$ , with  $f^-(\phi_n) > \mu$ . We also find  $\{t_n\}_{n \in \mathbb{N}} \in \mathbb{R}^+$  such that  $t_n \in [0, s^+(\phi_n))$  and  $\alpha(t_n)F(\phi_n(t_n)) > \mu$ , for all  $n \in \mathbb{N}$ . We may assume, w. l. g., that  $\phi_n \rightarrow \phi$ , uniformly on compact sets of  $\mathbb{R}^+$ , for some  $\phi \in \mathcal{R}$  with  $\phi(0) = x_0$ .

There are two possibilities:  $\{t_n\}_{n \in \mathbb{N}}$  is bounded or  $t_n \rightarrow +\infty$  as  $n$  goes to  $+\infty$ .

In the first case, we may assume that  $t_n$  converges to some  $t_0 \in \mathbb{R}^+$  as  $n$  goes to  $+\infty$ . Thus,  $\mu \leq \alpha(t_0)F(\phi(t_0))$ . By the hypothesis, it follows that  $f^-(\phi) < \mu$ , hence  $t_0 > s^+(\phi)$ . Consequently, there is a  $T \in (s^+(\phi), t_0)$  such that  $\phi(T) \in X \setminus N$ . Since  $X \setminus N$  is open,  $\phi_n(T) \rightarrow \phi(T)$  and  $t_n \rightarrow t_0$  as  $n$  goes to  $+\infty$ , we find  $n_0 \in \mathbb{N}$  sufficiently large such that  $\phi_n(T) \in X \setminus N$  and  $T \leq t_{n_0} < s^+(\phi_{n_0})$ . But this is a contradiction with the definition of  $s^+(\phi_{n_0})$ .

Now, if we assume that  $t_n \rightarrow +\infty$ , then  $s^+(\phi) = +\infty$ . Taking a subsequence if necessary, we have  $\phi_n(t_n) \rightarrow y$ , for some  $y \in A^-(N)$ , by Proposition 6.2.6. As a consequence,  $\alpha(t_n)F(\phi_n(t_n)) \rightarrow 0$  as  $n \rightarrow +\infty$ . But this is a contradiction with the hypothesis  $\mu < \alpha(t_n)F(\phi_n(t_n))$ , for all  $n \in \mathbb{N}$ .

Therefore,  $g^-$  is upper semicontinuous in  $N$ .

Now, we want to show that  $g^-$  is lower semicontinuous in any neighborhood  $W$  of  $K$  in  $\mathcal{O}(K) \cap U$  for which  $t^+(\phi) = s^+(\phi)$ , for all  $\phi \in \mathcal{R}$  with  $\phi(0) \in W$ . Consider any neighborhood  $W$  satisfying the required conditions. Assume, by contradiction, that there is a  $x \in W$ , such that  $g^-$  is not lower semicontinuous at  $x$ . Then, we can find  $\mu > 0$ ,  $x \in W$  and a sequence  $\{x_n\}_{n \in \mathbb{N}} \in W$  with  $x_n \rightarrow x$  as  $n \rightarrow +\infty$  and

$$g^-(x_n) \leq \mu < g^-(x). \quad (6.16)$$

Hence, we find  $\phi \in \mathcal{R}$ ,  $\phi(0) = x$  such that  $\mu < f^-(\phi)$ . By definition of  $f^-$  and by  $t^+(\phi) = s^+(\phi)$ , we find  $\tau \in (0, s^+(\phi))$  such that  $\phi([0, \tau]) \subset U$  and  $\alpha(\tau)F(\phi(\tau)) > \mu$ .

Using (K5), we may assume that we find a sequence  $\{\phi_n\}_{n \in \mathbb{N}} \in \mathcal{R}$ , with  $\phi_n(0) = x_n$ ,  $n \in \mathbb{N}$ , and such that  $\phi_n \rightarrow \phi$  uniformly on compact sets of  $\mathbb{R}^+$ . The continuity of  $F$  assures that we can find  $n_0 \in \mathbb{N}$ , such that, for all  $n \geq n_0$ ,  $\phi_n([0, \tau]) \subset U$  and

$$\alpha(\tau)F(\phi_n(\tau)) > \mu.$$

On the other hand, by (6.16) it follows that

$$\mu < \alpha(\tau)F(\phi_n(\tau)) \leq f^-(\phi_n) \leq g^-(x_n) \leq \mu,$$

which is a contradiction. □

**Lemma 6.2.12.** Assume (K1)-(K4). Let  $K \neq \emptyset$  be a closed isolated weakly invariant set. Suppose  $N$  is a closed  $G$ -admissible isolating neighborhood of  $K$ . Assume that we have a sequence  $\{x_n\}_{n \in \mathbb{N}} \in U$  such that  $g^+(x_n) \rightarrow 0$  and  $g^-(x_n) \rightarrow 0$  as  $n \rightarrow +\infty$ . Then we find a subsequence  $\{x_{n_m}\}_{m \in \mathbb{N}}$  and  $x \in K$  such that  $x_{n_m} \rightarrow x$  as  $m \rightarrow +\infty$ .

*Proof.* By the definition of  $g^+$ , for each  $n \in \mathbb{N}$ , we can find  $\phi_n \in \mathcal{U}_{x_n}$ , such that  $f^+(\phi_n) \rightarrow 0$  as  $n \rightarrow +\infty$ .

Now, by definition of  $g^-$ ,  $f^-(\phi_n) \rightarrow 0$  and, consequently,  $d(x_n, A^-(N)) = F(x_n) \rightarrow 0$  as  $n \rightarrow +\infty$ . Since  $A^-(N)$  is compact, by Proposition 6.2.6, we may assume that  $x_n \rightarrow x$ , for some  $x \in A^-(N)$ .

Now, we have two possibilities: Either  $\{t^+(\phi_n)\}_{n \in \mathbb{N}}$  is bounded or it is unbounded.

- i) Suppose that there exists a  $M > 0$  such that  $t^+(\phi_n) < M$  for all  $n \in \mathbb{N}$ . Then, for each  $n \in \mathbb{N}$ , we find  $t_n \in [0, t^+(\phi_n)]$  with

$$f^+(\phi_n) \geq \frac{\inf\{D(\phi_n(t)) : t \in [0, t^+(\phi_n)]\}}{1+M} = \frac{D(\phi_n(t_n))}{1+M}. \quad (6.17)$$

Without loss of generality we may assume that  $t_n \rightarrow t_0 < \infty$ , as  $n \rightarrow +\infty$ , for some  $t_0 \in \mathbb{R}^+$ . By (K4) and Proposition 6.2.6, we may assume that there is  $\phi \in \mathcal{R}$  with  $\phi(0) = x$  and  $\phi([0, t_0]) \subset N$ , for which  $\phi_n \rightarrow \phi$  uniformly on compact sets of  $\mathbb{R}^+$ . Since  $D(\phi_n(t_n)) \rightarrow D(\phi(t_0))$  as  $n \rightarrow +\infty$ , by (6.17), we obtain  $D(\phi(t_0)) = 0$  and  $\phi(t_0) \in K$ .

In particular, it follows that  $x \in A^+(N)$ . Thus  $x \in K$ .

- ii) If  $\{t^+(\phi_n)\}_{n \in \mathbb{N}}$  is unbounded.

We may assume that  $t^+(\phi_n) \rightarrow +\infty$  and, by Proposition 6.2.6, we have  $x \in A^+(N)$ .

Therefore,  $x \in A^-(N) \cap A^+(N) = K$ , as desired. □



**Lemma 6.2.13.** Let  $K \neq \emptyset$  be a closed isolated weakly invariant set. Assume (K1)-(K5). Suppose  $N$  is a closed  $G$ -admissible isolating neighborhood of  $K$ . Consider  $\varepsilon > 0$  and the set

$$H_\varepsilon = \{x \in U \cap \mathcal{O}(K) : g^+(x) < \varepsilon, g^-(x) < \varepsilon\}.$$

Then  $H_\varepsilon$  is open in  $U \cap \mathcal{O}(K)$ . We can choose  $\varepsilon > 0$  small enough such that  $g^+$  is continuous on  $clH_\varepsilon$  and  $clH_\varepsilon$  is an isolating neighborhood of  $K$ .

*Proof.* Since, by Proposition 6.2.11, both  $g^+$  and  $g^-$  are upper semicontinuous in  $U \cap \mathcal{O}(K)$ ,  $H_\varepsilon$  is open for every  $\varepsilon > 0$ . Observe that  $K \subset H_\varepsilon$  since  $g^+(x) = g^-(x) = 0$ , for all  $x \in K$ .

Consider  $W \subset U \cap \mathcal{O}(K)$ , an open neighborhood of  $K$  for which  $g^+$  is continuous in  $W$ , whose existence is assured by Proposition 6.2.11. We want to show that there is  $\varepsilon > 0$  such that  $clH_\varepsilon \subset W$ . If this was not true, then we would find sequences  $\{\varepsilon_n\}_{n \in \mathbb{N}} \in \mathbb{R}^+$ ,  $\{y_n\}_{n \in \mathbb{N}} \in X$ , with  $y_n \in clH_{\varepsilon_n} \setminus W$ , for all  $n \in \mathbb{N}$ , and  $\varepsilon_n \rightarrow 0$  as  $n \rightarrow +\infty$ . For each  $n \in \mathbb{N}$ , take  $x_n \in H_{\varepsilon_n}$  with  $d(x_n, y_n) < \varepsilon_n$ . It follows that  $g^+(x_n)$  and  $g^-(x_n)$  go to 0 as  $n \rightarrow +\infty$ . By Lemma 6.2.12, we may assume that  $x_n \rightarrow x \in K$  and then  $y_n \rightarrow x$ . We thus obtain that  $x \in K$  but  $x \notin W$ , which is a contradiction since  $K \subset W$ . Therefore,  $g^+$  is continuous in  $clH_\varepsilon$ .

Finally, as  $K \subset H_\varepsilon \subset N$ , the largest weakly invariant subset of  $H_\varepsilon$  contains  $K$  and it must be inside  $N$ , hence it must be  $K$ .  $\square$

**Theorem 6.2.14.** Let  $K \neq \emptyset$  be a closed isolated weakly invariant set. Suppose that  $\mathcal{R}$  satisfies (K1)-(K5) and that there is a closed isolating neighborhood  $N$  of  $K$  which is  $G$ -admissible. Then there exists an isolating block  $B$  with  $K \subset B \subset N$ .

*Proof.* Choose  $\varepsilon_0 > 0$ , the number provided in Lemma 6.2.13. For  $\varepsilon = \frac{\varepsilon_0}{2}$ ,  $\tilde{U} = H_\varepsilon$  and  $\tilde{N} = clH_\varepsilon \subset U \cap \mathcal{O}(K)$ .

Define the functions  $\tilde{t}^+$ ,  $\tilde{s}^+$  and  $\tilde{g}^+$ ,  $\tilde{g}^-$  as before, with  $U$  (resp.  $N$ ) replaced by  $\tilde{U}$  (resp.  $\tilde{N}$ ). Observe that all the previous results can be applied to these functions defined above. It is also easy to see that  $\tilde{N}$  is admissible.

We want to show that  $\tilde{t}^+(\phi) = \tilde{s}^+(\phi)$ , for every  $\phi \in \mathcal{R}$ , with  $\phi(0) \in \tilde{U}$ . Clearly,  $\tilde{t}^+(\phi) \leq \tilde{s}^+(\phi)$ , for every  $\phi \in \mathcal{R}$ , with  $\phi(0) \in \tilde{U}$ . Suppose, by contradiction, that we can find  $x \in \tilde{U}$  and  $\psi \in \mathcal{R}$  with  $\psi(0) = x$  and such that  $\tilde{t}^+(\psi) < \tilde{s}^+(\psi)$ .

We have  $y = \psi(\tilde{t}^+(\psi)) \in \partial\tilde{U} \subset U \cap \mathcal{O}(K)$ . Hence, either  $g^+(y) \geq \varepsilon$  or  $g^-(y) \geq \varepsilon$ . Since  $x \in \tilde{U}$  and  $g^-(x) \geq g^-(y)$ , by Proposition 6.2.8, it follows that the last scenario above cannot happen. So, necessarily  $g^+(y) \geq \varepsilon$ . Now as  $y \in \partial\tilde{U}$ , we find a sequence  $\{y_n\}_{n \in \mathbb{N}} \in \tilde{U}$  with  $y_n \rightarrow y$  as  $n \rightarrow +\infty$ . Then  $g^+(y_n) < \varepsilon$  and then, by the continuity of  $g^+$  in  $H_{\varepsilon_0}$ , we have  $g^+(y) = \varepsilon$ .

Choose  $t \in (\tilde{t}^+(\psi), \tilde{s}^+(\psi))$ . Then  $\psi([0, t]) \subset \tilde{N}$  and we have  $g^+(\psi(t)) \leq \varepsilon$ . On the other hand, the strict inequality property of  $g^+$  along orbits in  $U$  implies that  $g^+(\psi(t)) > g^+(y) = \varepsilon$ , which is a contradiction.

Therefore,  $\tilde{t}^+(\phi) = \tilde{s}^+(\phi)$ , for all  $\phi \in \mathcal{R}$ , with  $\phi(0) \in \tilde{U}$ . Consequently, by Proposition 6.2.11, we conclude that  $\tilde{g}^-$  is continuous in  $\tilde{U}$ .

Take  $\delta \in (0, \varepsilon)$  and define

$$B = clH_\delta = cl\{x \in \tilde{U} : \tilde{g}^+(x) < \delta, \tilde{g}^-(x) < \delta\}.$$

Applying Lemma 6.2.13 to  $\tilde{U}$  and  $\tilde{N}$  we obtain  $\delta < \varepsilon$  such that:

- $\tilde{H}_\delta$  is open in  $U \cap \mathcal{O}(K)$ ,  $K \subset \tilde{H}_\delta$  and  $cl\tilde{H}_\delta \subset U \cap \mathcal{O}(K)$ ;
- $\tilde{g}^+, \tilde{g}^-$  are continuous on  $cl\tilde{H}_\delta$ .

Let us show that  $B \subset H_\varepsilon$ . In fact, if  $x \in B$ , then  $x \in \tilde{U}$  and there is a sequence  $\{x_n\}_{n \in \mathbb{N}} \in H_\delta$  with  $x_n \rightarrow x$ , as  $n \rightarrow \infty$ . Hence  $\tilde{g}^+(x_n) < \delta$  and  $\tilde{g}^-(x_n) < \delta$ . The continuity of  $\tilde{g}^+$  and  $\tilde{g}^-$  imply that  $\tilde{g}^+(x), \tilde{g}^-(x) \leq \delta < \varepsilon$ .

Now, observe that  $\partial B = b^- \cup b^+ \cup b^*$ , where

$$b^- = \{x \in \partial B : \tilde{g}^+(x) = \delta, \tilde{g}^-(x) < \delta\},$$

$$b^+ = \{x \in \partial B : \tilde{g}^+(x) < \delta, \tilde{g}^-(x) = \delta\},$$

$$b^* = \{x \in \partial B : \tilde{g}^+(x) = \delta, \tilde{g}^-(x) = \delta\}.$$

Consider a point  $x \in \partial B$  and a function  $\phi : [-\tau_1, +\infty) \rightarrow X$  such that  $\phi(\cdot + \tau_1) \in \mathcal{R}$  with  $\phi(0) = x$  and  $\phi([-\tau_1, \tau_2]) \subset \tilde{U}$ , for constants  $\tau_1 \geq 0$  and  $\tau_2 > 0$ .

- Suppose that  $x \in b^-$ . By definition of  $b^-$  and the monotonicity of  $\tilde{g}^+$  and  $\tilde{g}^-$  along orbits we have, for  $t \in (0, \tau_2]$ ,

$$\tilde{g}^+(\phi(t)) > \tilde{g}^+(x) = \delta \text{ and } \tilde{g}^-(\phi(t)) \leq \tilde{g}^-(x) < \delta.$$

Then  $\phi((0, \tau_2]) \subset X \setminus B$ .

Now if  $\tau_1 > 0$ , since  $\tilde{g}^+$  is continuous and  $\phi(\cdot + \tau_1) \in \mathcal{R}$ , we find  $\sigma_1 \in (0, \tau_1)$  such that  $\tilde{g}^+(\phi(\sigma_1)) \neq 0$ . By the monotonicity of  $\tilde{g}^+$  along orbits on  $\tilde{U}$ , we find  $\tilde{g}^+(\phi(t)) < \tilde{g}^+(x) = \delta$ , for all  $t \in [-\sigma_1, 0)$ . The continuity of  $\tilde{g}^-$  assures that there is a  $\tau \in [-\sigma_1, 0)$  for which  $\tilde{g}^-(\phi(t)) < \delta$ , for all  $t \in [\tau, 0)$ .

Hence,  $\phi([\tau, 0)) \subset \text{int}B$ .

Therefore, each point of  $b^-$  is an egress point, see Definition 6.2.2.

- Suppose that  $x \in b^+$ . By the monotonicity of  $\tilde{g}^-$  along orbits in  $\tilde{U}$ , we have, for  $t \in (0, \tau_2]$ ,

$$\tilde{g}^-(\phi(t)) < \tilde{g}^-(x) = \delta,$$

and, since  $\tilde{g}^+(x) < \delta$ , by the continuity of  $\tilde{g}^+$ , we find  $\tau \in (0, \tau_2]$  such that  $\tilde{g}^+(\phi(t)) < \delta$  for  $t \in (0, \tau]$ . Hence,  $\phi((0, \tau]) \subset \text{int}B$ .

Also, if  $\tau_1 > 0$ , by the monotonicity of  $\tilde{g}^-$  and  $\tilde{g}^+$  along orbits on  $\tilde{U}$ , we have  $\tilde{g}^+(\phi(t)) \leq \tilde{g}^+(x) < \delta$  and  $\tilde{g}^-(\phi(t)) > \tilde{g}^-(x) = \delta$ , for  $t \in [-\tau_1, 0)$ . Then  $\phi([-\tau_1, 0)) \subset X \setminus B$ .

That means each point of  $b^-$  is an ingress point.

- Suppose that  $x \in b^*$ . By the monotonicity of  $\tilde{g}^+$  and  $\tilde{g}^-$  along orbits in  $\tilde{U}$ , we have, for all  $t \in (0, \tau_2]$ ,  $\delta = \tilde{g}^+(x) < \tilde{g}^+(\phi(t))$  and  $\delta = \tilde{g}^-(x) > \tilde{g}^-(\phi(t))$ .

Also, if  $\tau_1 \neq 0$ ,  $\delta = \tilde{g}^+(x) \geq \tilde{g}^+(\phi(t))$  and  $\delta = \tilde{g}^-(x) < \tilde{g}^-(\phi(t))$ , for all  $t \in [-\tau_1, 0)$ .

Thus  $\phi(t) \in X \setminus B$ , for all  $t \in [-\tau_1, 0) \cup (0, \tau_2]$ .

That means each point of  $b^*$  is a bounce-off point.

Finally, it is clear to see that  $B^- = b^- \cup b^*$  is closed. Therefore,  $B$  is an isolating block  $\square$

**Theorem 6.2.15.** Let  $\tilde{\mathcal{R}} \supset \mathcal{R}$  be sets of functions satisfying (K1) – (K4) and let  $\tilde{G} \supset G$  be their associated multivalued semiflows. Assume that  $K$  is a closed isolated weakly invariant set for  $G$  with the closed isolating  $G$ -admissible neighborhood  $N$ . Also, let  $\tilde{K}$  be a closed isolated weakly invariant set for  $\tilde{G}$  such that  $K \subset \tilde{K}$  and  $N$  is an isolating  $\tilde{G}$ -admissible neighborhood for  $\tilde{K}$  as well. Moreover, we suppose that  $\tilde{\mathcal{R}}$  satisfies (K5) for  $\tilde{K}$ . Then there is an isolating block  $B$  for  $K$ .

*Proof.* Since  $\tilde{\mathcal{R}}$  satisfies (K1)-(K5) for  $\tilde{K}$ , the set  $M = \overline{N \cap O(\tilde{K})}$  (where  $O(\tilde{K})$  is the neighborhood from condition (K5)) is a closed isolating admissible neighborhood of  $\tilde{K}$ . Hence, by Theorem 6.2.14,  $\tilde{K}$  has an isolating block  $B$  for  $\tilde{G}$ . Since any  $\varphi \in \mathcal{R}$  belongs to  $\tilde{\mathcal{R}}$ ,  $B$  is also an isolating block of  $K$  for  $G$ .  $\square$

## 6.3 Application

Let us consider the differential inclusion

$$\begin{cases} \frac{\partial u}{\partial t} - \frac{\partial^2 u}{\partial x^2} \in H_0(u) + \omega u, & \text{on } (0, \infty) \times \Omega, \\ u|_{\partial\Omega} = 0, \\ u(x, 0) = u_0(x), \end{cases} \quad (6.18)$$

where  $\Omega = (0, 1)$ ,  $0 \leq \omega < \pi^2$ , and

$$H_0(u) = \begin{cases} -1, & \text{if } u < 0, \\ [-1, 1], & \text{if } u = 0, \\ 1, & \text{if } u > 0 \end{cases}$$

is the Heaviside function, see Figure 14.

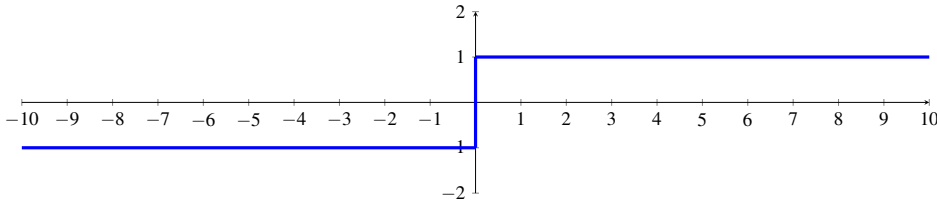

Figure 14 – Representation of the Heaviside function

Differential inclusions of the type appear when we have a reaction-diffusion equation with a discontinuous nonlinearity and we complete the image of the function at the points of discontinuity with a vertical line. Equations of this type appear in models of physical interest (see, for example, (FEIREISL; NORBURY, 1991), (NORTH; CAHALAN, 1981), (TERMAN, 1983), (TERMAN, 1985)).

In this section, we will prove the existence of isolating blocks for the fixed points (but 0) of problem (6.18) by using the results of Section 6.2. Also, we will prove a uniqueness theorem for initial conditions of certain type.

### 6.3.1 Previous results

We recall what is known about the dynamics of problem (6.18).

Problem (6.18) can be written in a functional form. Indeed, we define the following proper, convex, lower semicontinuous functions  $\psi^i : L^2(\Omega) \rightarrow (-\infty, +\infty]$ :

$$\psi^1(u) = \begin{cases} \frac{1}{2} \int_{\Omega} |\nabla u|^2 dx, & \text{if } u \in H_0^1(\Omega), \\ +\infty, & \text{otherwise,} \end{cases}$$

$$\psi^2(u) = \begin{cases} \int_{\Omega} \left( \omega \frac{u^2}{2} + |u| \right) dx, & \text{if } |u(\cdot)| \in L^1(\Omega), \\ +\infty, & \text{otherwise.} \end{cases}$$

It is known (see e.g. (BARBU, 1976)) that the subdifferentials  $\partial\psi^1$  and  $\partial\psi^2$  of these functions are given by

$$\partial\psi^1(u) = \left\{ y \in L^2(\Omega) : y(x) = -\frac{\partial^2 u}{\partial x^2}(x), \text{ a.e. on } \Omega \right\},$$

$$\partial\psi^2(u) = \{ y \in L^2(\Omega) : y(x) \in H_0(u(x)) + \omega u(x), \text{ a.e. on } \Omega \}.$$

Hence, problem (6.18) can be rewritten in the abstract form

$$\begin{cases} \frac{\partial u}{\partial t} + \partial\psi^1(u) - \partial\psi^2(u) \ni 0, \\ u(0) = u_0. \end{cases} \quad (6.19)$$

We observe that  $|u| = \int_0^u H_0(s) ds$  and  $D(\partial\psi^1) = H^2(\Omega) \cap H_0^1(\Omega)$ ,  $D(\partial\psi^2) = L^2(\Omega)$ .

**Definition 6.3.1.** For  $u_0 \in L^2(\Omega)$  and  $T > 0$  the function  $u \in C([0, T], L^2(\Omega))$  is called a strong solution of problem (6.18) on  $[0, T]$  if:

- (i)  $u(0) = u_0$ ;
- (ii)  $u(\cdot)$  is absolutely continuous on  $(0, T)$  and  $u(t) \in D(\partial\psi^1)$  for a.a.  $t \in (0, T)$ ;
- (iii) There exist a function  $g \in L^2(0, T; L^2(\Omega))$  such that  $g(t) \in \partial\psi^2(u(t))$ , a.e. on  $(0, T)$ , and

$$\frac{du(t)}{dt} - \frac{\partial^2 u(t)}{\partial x^2} - g(t) = 0, \text{ for a.a. } t \in (0, T), \quad (6.20)$$

where the equality is understood in the sense of the space  $L^2(\Omega)$ .

**Remark 6.3.2.** Alternatively, equality (6.20) can be written as

$$\frac{du(t)}{dt} - \frac{\partial^2 u(t)}{\partial x^2} - h(t) = \omega u(t), \text{ for a.a. } t \in (0, T), \quad (6.21)$$

where  $h \in L^2(0, T; L^2(\Omega))$  and  $h(t, x) \in H_0(u(t, x))$ , for a.e.  $t > 0$ ,  $x \in \Omega$ .

From (VALERO, 2001, Theorem 4, Lemmas 1 and 2) we know the following facts. For each  $u_0 \in L^2(\Omega)$  and  $T > 0$  there exists at least one strong solution  $u(\cdot)$  of (6.18) and each solution can be extended to the whole semiline  $[0, \infty)$ , so that they are global. Moreover, any solution  $u(\cdot)$  belongs to the space  $C((0, +\infty), H_0^1(\Omega))$  and, if  $u_0 \in H_0^1(\Omega)$ , then  $u \in C([0, +\infty), H_0^1(\Omega))$ .

Let  $\mathcal{D}(u_0)$  be the set of all strong solutions defined on  $[0, +\infty)$  for the initial condition  $u_0$  and let  $\mathcal{R} = \cup_{u_0 \in L^2(\Omega)} \mathcal{D}(u_0)$ . Let  $G : \mathbb{R}^+ \times L^2(\Omega) \rightarrow P(L^2(\Omega))$  be the map

$$G(t, u_0) = \{u(t) : u \in \mathcal{D}(u_0)\},$$

which is a strict multivalued semiflow. Moreover, properties (K1) – (K3) are satisfied for  $\mathcal{R}$ . Also, (K4) is shown to be true in (COSTA; VALERO, 2017, Lemma 31).

Concerning the asymptotic behavior of solutions in the long term,  $G$  possesses a global compact invariant attractor  $\mathcal{A}$  (VALERO, 2001, Theorem 4), which is characterized by the union of all bounded complete trajectories. In addition,  $\mathcal{A}$  is compact in  $W^{2-\delta, p}(\Omega)$  for all  $\delta > 0$ ,  $p \geq 1$  and

$$\text{dist}_{W^{2-\delta, p}}(G(t, B), \mathcal{A}) \rightarrow 0, \text{ as } t \rightarrow +\infty,$$

for any bounded set  $B$  (ARRIETA; RODRÍGUEZ-BERNAL; VALERO, 2006). It follows then that  $\mathcal{A}$  is compact in  $C^1([0, 1])$  and  $\text{dist}_{C^1}(G(t, B), \mathcal{A}) \rightarrow 0$  as  $t \rightarrow +\infty$ . Also, it is proved in (VALERO, 2005) that  $\mathcal{A}$  is a connected set.

The structure of the attractor was studied in detail in (ARRIETA; RODRÍGUEZ-BERNAL; VALERO, 2006). We summarize the main results. Problem (6.18) has an infinite (but countable) number of fixed points:  $v_0 \equiv 0$ ,  $v_1^+$ ,  $v_1^-$ ,  $v_2^+$ ,  $v_2^-$ , ..., which satisfy the following properties:

1.  $v_k^\pm$  possess exactly  $k - 1$  zeros in  $(0, 1)$  and  $v_k^+ = -v_k^-$ , for all  $k \in \mathbb{N}$ ;
2.  $v_1^+$ ,  $v_1^-$  are asymptotically stable (so for  $u_0 = v_1^\pm$  the solution is unique);

3.  $0, v_k^\pm, k \geq 2$ , are unstable;
4.  $v_k^\pm \rightarrow 0$  as  $k \rightarrow \infty$ .

We define the continuous function  $E : H_0^1(0, 1) \rightarrow \mathbb{R}$  by

$$E(u) = \frac{1}{2} \int_0^1 \left| \frac{\partial u}{\partial x} \right|^2 dx - \int_0^1 \left( |u| + \frac{\omega}{2} u^2 \right) dx = \psi^1(u) - \psi^2(u). \quad (6.22)$$

It is shown in in (ARRIETA; RODRÍGUEZ-BERNAL; VALERO, 2006) that  $E$  is a Lyapunov function and then that for any  $u \in \mathcal{D}(u_0), u_0 \in L^2(\Omega)$ , there is a fixed point  $z$  such that  $u(t) \rightarrow z$  as  $t \rightarrow +\infty$ . We note that by the regularity of the solutions,  $E(u(t)) : (0, +\infty) \rightarrow \mathbb{R}$  is a continuous function. We note also that if  $u_0 \in H_0^1(\Omega)$ , then  $E(u(t))$  is continuous on  $[0, +\infty)$ . Also, if  $\phi$  is a bounded complete trajectory, then there is a fixed point  $z$  such that  $\phi(t) \rightarrow z$  as  $t \rightarrow -\infty$ . Therefore, the global attractor is characterized by the set of stationary points and their heteroclinic connections. In (ARRIETA; RODRÍGUEZ-BERNAL; VALERO, 2006), some of these connections have been established, although the question of determining the full set of connections is still open. The fixed points are ordered by the Lyapunov function  $E$  in the following way:

$$E(v_1) = E(v_1^-) < E(v_2) = E(v_2^-) < \dots < E(v_k) = E(v_k^-) < \dots < E(0) = 0.$$

In particular, this implies that heteroclinic connections from  $v_k^\pm$  to  $v_j^\pm$  with  $k \leq j$  are forbidden. Finally, we observe that the fixed point  $0$  is special, because for any other fixed point  $z = v_k^+$  (or  $v_k^-$ ) there exists a solution  $u(\cdot)$  starting at  $0$  such that  $u(t) \rightarrow z$  as  $t \rightarrow +\infty$ . The conclusion is two-fold: on the one hand, for the initial condition  $u_0 = 0$  there exists an infinite number of solutions; on the other hand, for any  $z = v_k^+$  (or  $v_k^-$ ) there exists an heteroclinic connection from  $0$  to  $z$ .

### 6.3.2 Isolating block

In order to understand the dynamics inside of the global attractor it is important to know what happens in a neighborhood of each fixed point. Reasoning as in (COSTA; VALERO, 2017, p.32) we can establish that each  $v_k^+$  (or  $v_k^-$ ),  $k \geq 1$ , is an isolated weakly invariant set, for  $k \in \mathbb{N}$ . The point  $0$  is not isolated since  $v_k^\pm \rightarrow 0$  as  $k \rightarrow +\infty$ . Applying the results of the previous section we will obtain the existence of an isolating block for each  $v_k^+$  ( $v_k^-$ ),  $k \geq 1$ .

It is not possible to apply directly Theorem 6.2.14, because the solutions of (6.18) do not satisfy condition (K5), as the following lemma shows.

**Lemma 6.3.3.** There exists a sequence  $\{u_0^n\}_{n \in \mathbb{N}}$  and a solution  $u(\cdot) \in \mathcal{D}(0)$  such that  $u_0^n \rightarrow 0$  and there is no subsequence of solutions  $\{u^{n_k}(\cdot)\}_{k \in \mathbb{N}}$  with  $u^{n_k}(0) = u_0^{n_k}$  such that  $u^{n_k} \rightarrow u$  (in the sense of (K5)).

*Proof.* Let  $u_0^n \in V^{2r}$ ,  $\frac{3}{4} < r < 1$ , where  $V^{2r} = D(A^r)$  and  $A, D(A) = H^2(\Omega) \cap H_0^1(\Omega)$ , is the operator  $-\frac{d^2}{dx^2}$  with Dirichlet boundary conditions. For each  $n \in \mathbb{N}$ , we choose  $u_0^n$  such that  $\frac{d}{dx}u_0^n(0) > 0$ ,  $\frac{d}{dx}u_0^n(0) < 0$ ,  $u_0^n(x) > 0$  for  $x \in (0, 1)$  (we observe that  $V^{2r} \subset C^1(\overline{\Omega})$ ) and  $u_0^n \rightarrow 0$ . Then by (VALERO, 2021, Lemma 13) there exists a unique solution  $u^n(\cdot) \in \mathcal{D}(u_0^n)$  which satisfies  $u^n(t, x) > 0$  for any  $x \in (0, 1)$  and  $t \geq 0$ . Also, it converges to  $v_1^+$  as  $t \rightarrow +\infty$ . We know from (ARRIETA; RODRÍGUEZ-BERNAL; VALERO, 2006, Theorem 6.7) that there exists a solution  $v(\cdot)$  such that  $v(0) = 0$  and  $v(t) \rightarrow v_1^-$  in  $C^1(\overline{\Omega})$  as  $t \rightarrow +\infty$ . It is clear that no subsequence of  $u^n(\cdot)$  can converge to  $v(\cdot)$ , because  $u^n(t)$  is positive for any  $t \geq 0$  but  $v(t)$  take negative values for  $t$  large enough.  $\square$

In order to apply Theorem 6.2.15, we need to define a semiflow  $\tilde{G}$  containing  $G$  that satisfies (K1) – (K5).

For this aim, for any  $\varepsilon > 0$ , let us define the multivalued function  $g_\varepsilon$  given by

$$g_\varepsilon(u) = \begin{cases} -1 & \text{if } u \leq -\varepsilon, \\ [-1, \frac{2}{\varepsilon}u + 1] & \text{if } -\varepsilon \leq u \leq 0, \\ [\frac{2}{\varepsilon}u - 1, 1] & \text{if } 0 \leq u \leq \varepsilon, \\ 1 & \text{if } u \geq \varepsilon. \end{cases}$$

It is easy to see that the map  $f_\varepsilon(u) = g_\varepsilon(u) + \omega u$  satisfies conditions (f1) – (f2) for problem (6.2). Then problem (6.2) with  $f = f_\varepsilon$  and  $q = 0$  generates, for each  $\varepsilon > 0$ , a strict multivalued semiflow  $G_\varepsilon$  which contains the semiflow  $G$  for problem (6.18) (as every solution to problem (6.18) is obviously a solution to problem (6.2)).

We denote by  $\mathcal{D}_\varepsilon(u_0)$  the set of all strong solutions defined on  $[0, +\infty)$  for the initial condition  $u_0$ . Let  $\mathcal{R}_\varepsilon = \cup_{u_0 \in L^2(\Omega)} \mathcal{D}_\varepsilon(u_0)$ . It follows from the proof of Lemma 6 in (MELNIK; VALERO, 1998) that (K1) – (K3) hold true. In view of Corollary 6.1.10, (K5) is satisfied. We prove that (K4) holds as well.

**Lemma 6.3.4.** (K4) is satisfied.

*Proof.* Let  $u_0^n \rightarrow u_0$ . In view of (6.9), for any  $u^n(\cdot) \in \mathcal{D}_\varepsilon(u_0^n)$  there exists  $u_n(\cdot) \in \mathcal{D}_\varepsilon(u_0)$  such that

$$\|u^n(t) - u_n(t)\|_{L^2} \leq \|u_0^n - u_0\|_{L^2} \exp(2Ct), \forall t \geq 0. \quad (6.23)$$

Fix  $T > 0$ . Let  $\pi_T \mathcal{D}_\varepsilon(u_0)$  be the restriction of  $\mathcal{D}_\varepsilon(u_0)$  onto  $C([0, T], L^2(\Omega))$ . Since the set  $\pi_T \mathcal{D}_\varepsilon(u_0)$  is compact in  $C([0, T], L^2(\Omega))$  (MELNIK; VALERO, 1998, p.100), passing to a subsequence we have that  $u_n \rightarrow u \in \mathcal{D}_\varepsilon(u_0)$  in  $C([0, T], L^2(\Omega))$ . Thus, by (6.23) we obtain that  $u^n \rightarrow u$  in  $C([0, T], L^2(\Omega))$ . By a diagonal argument we deduce that for some subsequence this is true for any  $T > 0$ , proving property (K4).  $\square$



From (MELNIK; VALERO, 1998) we know that  $G_\varepsilon$  has a global compact invariant attractor  $\mathcal{A}_\varepsilon$ , for all  $\varepsilon > 0$ . It is clear that

$$\mathcal{A} \subset \mathcal{A}_{\varepsilon_1} \subset \mathcal{A}_{\varepsilon_2} \text{ for all } 0 < \varepsilon_1 < \varepsilon_2,$$

where  $\mathcal{A}$  is the attractor for problem (6.18). Also, as (K1) – (K4) hold,  $\mathcal{A}_\varepsilon$  is characterized by the union of all bounded global trajectories (KAPUSTYAN; KASYANOV; VALERO, 2014):

$$\mathcal{A}_\varepsilon = \{\phi(0) : \phi \text{ is a bounded complete trajectory of } \mathcal{R}_\varepsilon\}.$$

**Lemma 6.3.5.** If  $\varepsilon_n \rightarrow 0^+$ ,  $u_{\varepsilon_n} \in \mathcal{D}_{\varepsilon_n}(u_0^n)$  and  $u_0^n \rightarrow u_0$ , then up to a subsequence  $u_{\varepsilon_n} \rightarrow u \in \mathcal{D}(u_0)$  uniformly on bounded sets of  $[0, +\infty)$ .

*Proof.* We fix  $\varepsilon_0 > 0$  such that  $\varepsilon_n < \varepsilon_0$ . Since  $u_{\varepsilon_n} \in \mathcal{D}_{\varepsilon_0}(u_0^n)$  for all  $n \in \mathbb{N}$ , by Lemma 6.3.4 we obtain that up to a subsequence  $u_{\varepsilon_n} \rightarrow u \in \mathcal{D}_{\varepsilon_0}(u_0)$  uniformly on bounded sets of  $[0, +\infty)$ . Hence,  $u(\cdot)$  is a strong solution to problem (6.7) with  $h \in L^2_{loc}(0, +\infty; L^2(\Omega))$ ,  $h(t) \in F_{\varepsilon_0}(u(t))$  for a.a.  $t$ , where  $F_{\varepsilon_0}$  is the map (6.4) for  $f_{\varepsilon_0}$ .

In order to prove that  $u \in \mathcal{D}(u_0)$ , it remains to show that  $h(t, x) \in H_0(u(t, x)) + \omega u(t, x)$  for a.a.  $(t, x)$ .

The selections  $h_n(\cdot)$  corresponding to  $u_{\varepsilon_n}(\cdot)$  in equality (6.7) are bounded by a constant  $C_T$  in each interval  $[0, T]$ :

$$\|h_n(t)\|_{L^2} \leq C_T \text{ for a.a. } t \in (0, T).$$

In particular, this means that  $h_n$  are integrably bounded in each interval and that up to a subsequence  $h_n \rightarrow \tilde{h}$  weakly in  $L^2(0, T; L^2(\Omega))$  for any  $T > 0$ . We need to check that  $\tilde{h} = h$ . Let  $v_n(\cdot) = I(u_0)h_n(\cdot)$ . Then by inequality (6.8) we have that  $v_n \rightarrow u$  in  $C([0, T], L^2(\Omega))$  for any  $T > 0$ . By Lemma 1.3 in (TOLSTONOGOV, 1992), we deduce that  $u(\cdot) = I(u_0)\tilde{h}(\cdot)$ , which is possible if and only if  $\tilde{h} = h$ .

Denote  $g(t) = h(t) - \omega u(t)$  and  $g_n(t) = h_n(t) - \omega u_n(t)$ ,  $n \in \mathbb{N}$ . We need to prove that  $g(t, x) \in H_0(u(t, x))$  for a.a.  $(t, x)$ . For a.a.  $(t, x)$  there is  $N(t, x)$  such that  $g_n(t, x) \in H_0(u(t, x))$  if  $n \geq N(t, x)$ . Indeed, since  $u_n(t, x) \rightarrow u(t, x)$  for a.a.  $(t, x)$ , we define  $B$  as a set which complementary  $B^c$  has measure 0 and such that  $u_n(t, x) \rightarrow u(t, x)$  for  $u(t, x) \in B$ . If  $u(t, x) \in B$  and  $u(t, x) > 0$  ( $< 0$ ), then there is  $N(t, x)$  such that  $u_n(t, x) > 0$  ( $< 0$ ) for  $n \geq N(t, x)$ . Hence,  $g_n(t, x) \in H_0(u_n(t, x)) = H_0(u(t, x)) = 1$  ( $-1$ ). If  $u(t, x) \in B$  and  $u(t, x) = 0$ , then  $g_n(t, x) \in [-1, 1] = H_0(u(t, x))$  for all  $n$ . By (TOLSTONOGOV, 1992, Proposition 1.1) for a.a.  $t$  there is a sequence of convex combinations

$$y_n(t) = \sum_{j=1}^{N_n} \lambda_j g_{k_j}(t), \quad \sum_{j=1}^{N_n} \lambda_j = 1, \quad k_j \geq n,$$

such that  $y_n(t) \rightarrow g(t)$  in  $L^2(\Omega)$ . Then, as  $H_0(u(t, x))$  is closed and convex,  $g(t, x) \in H_0(u(t, x))$  for a.a.  $(t, x)$ .  $\square$



**Corollary 6.3.6.** If  $\{\phi_{\varepsilon_n}\}_{n \in \mathbb{N}}$  is a sequence of bounded global trajectories of  $\mathcal{R}_{\varepsilon_n}$  and  $\varepsilon_n \rightarrow 0^+$ , then there exists a subsequence  $\{\phi_{\varepsilon_{n_k}}\}_{k \in \mathbb{N}}$  and a bounded complete trajectory  $\phi$  of  $\mathcal{R}$  such that

$$\phi_{\varepsilon_{n_k}} \rightarrow \phi \text{ in } C([-T, T], L^2(\Omega)) \text{ for all } T > 0. \quad (6.24)$$

*Proof.* Applying Lemma 6.3.5 and a diagonal argument we obtain a complete trajectory of  $\mathcal{R}$  and a subsequence such that (6.24) holds. Since for  $\varepsilon_0 > 0$  the complete trajectory  $\phi$  belongs to  $\mathcal{A}_{\varepsilon_0}$  and  $\mathcal{A}_{\varepsilon_0}$  is bounded, we obtain that  $\phi$  is a bounded complete trajectory of  $\mathcal{R}$ .  $\square$

We denote by  $O_\delta(v_0) = \{v \in X : \|v - v_0\|_{L^2} < \delta\}$  a  $\delta$ -neighborhood of the point  $v_0 \in L^2(\Omega)$ .

We choose  $\delta > 0$  such that  $v_k^+$  is the maximal weakly invariant set in  $O_\delta(v_k^+)$ , so that  $\overline{O}_\delta(v_k^+)$  is an isolating closed neighborhood of the stationary point  $v_k^+$ ,  $k \geq 1$  (for  $v_k^-$  the proof is the same). For the semiflow  $G_\varepsilon$ , we define a weakly invariant set associated to  $v_k^+$  in the following way:

$$K_\varepsilon = \{\phi(0) : \phi(\cdot) \text{ is a bounded complete trajectory of } \mathcal{R}_\varepsilon \text{ with } \phi(t) \in \overline{O}_\delta(v_k^+), \text{ for all } t \in \mathbb{R}\}.$$

**Lemma 6.3.7.** The set  $K_\varepsilon$  is compact.

*Proof.* Since  $K_\varepsilon \subset \mathcal{A}_\varepsilon$ , it is clearly relatively compact. Thus, we just need to prove that it is closed. Let  $y_n \rightarrow y$ , where  $y_n \in K_\varepsilon$ . Then  $y_n = \phi_n(0)$  for some bounded complete trajectory  $\phi_n$ ,  $n \in \mathbb{N}$ . Corollary 6.3.6 implies that up to a subsequence  $\phi_n \rightarrow \phi$  in  $C([-T, T], L^2(\Omega))$  for all  $T > 0$ , where  $\phi$  is a bounded complete trajectory. Obviously,  $\phi(t) \in \overline{O}_\delta(v_k^+)$ , for all  $t \in \mathbb{R}$ . Hence,  $y \in K_\varepsilon$ .  $\square$

**Lemma 6.3.8.** There is  $\varepsilon_0 > 0$  such that  $K_\varepsilon \subset O_{\delta/2}(v_k^+)$  for all  $\varepsilon \leq \varepsilon_0$ .

*Proof.* By contradiction, if this is not true, there is a sequence of bounded global trajectories  $\phi_{\varepsilon_n}$  of  $\mathcal{R}_{\varepsilon_n}$ , where  $\varepsilon_n \rightarrow 0^+$ , and times  $t_n$  such that  $\phi_{\varepsilon_n}(\mathbb{R}) \subset \overline{O}_\delta(v_k^+)$  and  $\phi(t_n) \notin O_{\delta/2}(v_k^+)$ . Making use of Corollary 6.3.6 and the fact that  $v_k^+$  is the unique bounded complete trajectory in  $O_\delta(v_k^+)$  for  $\mathcal{R}$ , we conclude that  $\phi_{\varepsilon_n} \rightarrow v_k^+$  in  $C([-T, T], L^2(\Omega))$  for all  $T > 0$ . This implies that the sequence  $\{t_n\}_{n \in \mathbb{N}}$  cannot be bounded. Indeed, suppose that a subsequence tends to  $+\infty$ . Then we define the sequence  $v_{\varepsilon_n}(\cdot) = \phi_{\varepsilon_n}(\cdot + t_n)$ , which again by Corollary 6.3.6 converges in  $C([-T, T], L^2(\Omega))$  to a bounded global trajectory  $\phi$  of  $\mathcal{R}$  such that  $\phi(\mathbb{R}) \subset \overline{O}_\delta(v_k^+)$ , so that  $\phi = v_k^+$ . But then  $v_{\varepsilon_n}(0) = \phi_{\varepsilon_n}(t_n) \rightarrow v_k^+$ , which is a contradiction. But if  $\{t_n\}_{n \in \mathbb{N}}$  is bounded, by a similar argument we obtain a contradiction.  $\square$

**Lemma 6.3.9.** There is  $\varepsilon_0 > 0$  such that  $K_\varepsilon$  is the maximal weakly invariant set in  $\overline{O}_\delta(v_k^+)$  for any  $\varepsilon \leq \varepsilon_0$ . Hence,  $\overline{O}_\delta(v_k^+)$  is an isolating neighborhood for  $K_\varepsilon$ .

*Proof.* In view of Lemmas 6.3.7 and 6.3.8,  $K_\varepsilon$  is closed and  $\overline{O}_\delta(v_k^+)$  is a neighborhood of  $K_\varepsilon$  such that  $K_\varepsilon \subset \text{int}(\overline{O}_\delta(v_k^+))$ . It is obvious that  $K_\varepsilon$  is the maximal weakly invariant set in  $\overline{O}_\delta(v_k^+)$ .  $\square$

**Remark 6.3.10.** Since the semiflows  $G, G_\varepsilon$  possess a compact global attractor, it is clear that any neighborhood (in particular  $\overline{O}_\delta(v_k^+)$ ) is admissible.

We are now ready to prove the existence of an isolating block.

**Theorem 6.3.11.** The stationary points  $v_k^\pm, k \geq 1$ , possess an isolating block.

*Proof.* It is a consequence of Lemma 6.3.9, Remark 6.3.10 and Theorem 6.2.15.  $\square$

### 6.3.3 Uniqueness of solutions

In this section we will prove a general result on uniqueness of solutions which allow us to obtain that in a suitable neighborhood of the fixed points  $v_k^\pm, k \geq 1$ , the solutions are unique while they remain inside it. In particular, the solutions starting at the fixed points  $v_k^\pm$  are unique.

The function  $v \in H_0^1(\Omega)$  is non-degenerate if there is  $C > 0$  and  $\alpha_0 > 0$  such that

$$\mu(\{x \in (0, 1) : |v(x)| \leq \alpha\}) \leq C\alpha \text{ for all } \alpha \in (0, \alpha_0), \quad (6.25)$$

where  $\mu$  stands for the Lebesgue measure in  $\mathbb{R}$ . A strong solution  $u : [0, T] \rightarrow H_0^1(\Omega)$  is said to be non-degenerate if there are  $C > 0$  and  $\alpha_0 > 0$  (independent on  $t$ ) such that

$$\mu(\{x \in (0, 1) : |u(t, x)| \leq \alpha\}) \leq C\alpha \text{ for all } \alpha \in (0, \alpha_0) \text{ and } t \in [0, T]. \quad (6.26)$$

For  $z \in \mathbb{R}$  denote  $z^+ = \max\{0, z\}$ .

**Lemma 6.3.12.** Let  $u_1, u_2 \in L^\infty(0, 1)$  and let either  $u_1$  or  $u_2$  be non-degenerate. Then for any  $z_1, z_2 \in L^\infty(0, 1)$  satisfying  $z_i(x) \in H_0(u_i(x))$ , for a.a.  $x \in (0, 1), i = 1, 2$ , we have

$$\int_0^1 (z_1(x) - z_2(x))(u_1(x) - u_2(x))^+ dx \leq 2D \|(u_1 - u_2)^+\|_{L^\infty}^2,$$

where  $D = \max\{C, \frac{1}{\alpha_0}\}$ , and  $C, \alpha_0$  are the constants in (6.25) for  $u_1$ .

*Proof.* If  $\|u_1 - u_2\|_{L^\infty} \geq \alpha_0$ , then

$$\int_0^1 (z_1(x) - z_2(x))(u_1(x) - u_2(x))^+ dx \leq 2 \|(u_1 - u_2)^+\|_{L^\infty} \leq \frac{2}{\alpha_0} \|(u_1 - u_2)^+\|_{L^\infty}^2.$$

So let  $\|u_1 - u_2\|_{L^\infty} < \alpha_0$ . We set

$$\begin{aligned} A^i &= \{x \in (0, 1) : u_i(x) = 0\}, \\ \Omega_+^i &= \{x \in (0, 1) : u_i(x) > 0\}, \\ \Omega_-^i &= \{x \in (0, 1) : u_i(x) < 0\}, \\ I &= \{x \in (0, 1) : u_1(x) > u_2(x)\}. \end{aligned}$$

Hence,  $z_1(x) = z_2(x)$  for  $x \in I_2 = ((\Omega_+^1 \cap \Omega_+^2) \cup (\Omega_-^1 \cap \Omega_-^2)) \cap I$ . Putting  $I_1 = I \setminus I_2$ , we have

$$\begin{aligned} \int_0^1 (z_1(x) - z_2(x))(u_1(x) - u_2(x))^+ dx &= \int_{I_1} (z_1(x) - z_2(x))(u_1(x) - u_2(x))^+ dx \\ &\leq 2 \|(u_1 - u_2)^+\|_{L^\infty} \mu(I_1). \end{aligned}$$

We observe that  $I_1 = (A^1 \cup A^2 \cup (\Omega_+^1 \cap \Omega_-^2)) \cap I$ . Since

$$0 \leq u_1(x) \leq u_2(x) + \|u_1 - u_2\|_{L^\infty} \leq \|u_1 - u_2\|_{L^\infty} \text{ for } x \in I_1,$$

if  $u_1$  is non-degenerate, we obtain

$$\mu(I_1) \leq \mu(\{x : |u_1(x)| \leq \|u_1 - u_2\|_{L^\infty}\}) \leq C \|u_1 - u_2\|_{L^\infty}.$$

In the same way, if  $u_2$  is non-degenerate, then

$$\mu(I_1) \leq \mu(\{x : |u_2(x)| \leq \|u_1 - u_2\|_{L^\infty}\}) \leq C \|u_1 - u_2\|_{L^\infty}.$$

Hence,

$$\int_0^1 (z_1(x) - z_2(x))(u_1(x) - u_2(x))^+ dx \leq 2C \|u_1 - u_2\|_{L^\infty}^2.$$

Putting  $D = \max\left\{C, \frac{1}{\alpha_0}\right\}$ , the result follows.  $\square$

**Remark 6.3.13.** Lemma 6.3.12 is true if we change  $(0, 1)$  by an arbitrary interval  $(0, \gamma)$ ,  $\gamma > 0$ .

For  $z_1, z_2 \in H_0^1(\Omega)$  we say that  $z_1 \leq z_2$  if  $z_1(x) \leq z_2(x)$  for all  $x \in [0, 1]$ .

**Theorem 6.3.14.** Let  $u_0, v_0 \in H_0^1(\Omega)$ , with  $u_0 \leq v_0$ . If  $u, v : [0, T] \rightarrow H_0^1(\Omega)$  are two strong solutions and either  $u$  or  $v$  is non-degenerate on  $[0, T]$ , then  $u(t) \leq v(t)$  for any  $t \in [0, T]$ .

*Proof.* For instance, let  $u$  be non-degenerate. Multiplying (6.21) by  $(u(t) - v(t))^+$  we have

$$\begin{aligned} &\frac{1}{2} \frac{d}{dt} \|(u - v)^+\|_{L^2}^2 + \|(u - v)^+\|_{H_0^1}^2 \\ &= \int_0^1 (f_u(t, x) - f_v(t, x))(u(t, x) - v(t, x))^+ dx + \omega \|(u - v)^+\|_{L^2}^2, \end{aligned}$$

where  $f_u, f_v \in L^\infty((0, T) \times (0, 1))$  and  $f_u(t, x) \in H_0(u(t, x))$ ,  $f_v(t, x) \in H_0(v(t, x))$  for a.a.  $(t, x)$ . Let  $L_\infty > 0$  be such that  $\|z\|_{L^\infty} \leq L_\infty \|z\|_{H_0^1}$  for  $z \in H_0^1(\Omega)$ . Hence, Lemma 6.3.12 and  $\omega < \pi^2$  imply that

$$\frac{1}{2} \frac{d}{dt} \|(u - v)^+\|_{L^2}^2 \leq (K - \beta^2) \|u - v\|_{L^\infty}^2,$$

where  $\beta = \left(\frac{1}{L_\infty}\right) \left(1 - \frac{\omega}{\pi^2}\right)^{\frac{1}{2}}$ ,  $K = 2D > 0$  and  $D$  is the constant in (6.26) for the solution  $u$ .

If  $K \leq \beta^2$ , then the result follows immediately. Thus, assume that  $K > \beta^2$ .

We introduce the rescaling  $y = \gamma x$ , where  $\gamma > 0$ . We put  $u_\gamma(t, y) := u(t, y/\gamma)$ , so  $(u_\gamma)_{yy}(t, y) := (u_\gamma)_{xx}(t, y/\gamma)/\gamma^2$ . Since

$$u_t(t, \frac{y}{\gamma}) - u_{xx}(t, \frac{y}{\gamma}) = f_u(t, \frac{y}{\gamma}) + \omega u(t, \frac{y}{\gamma}), \text{ for a.a. } t \in (0, T), 0 < y < \gamma,$$

we have

$$(u_\gamma)_t(t, y) - \gamma^2 (u_\gamma)_{yy}(t, y) = f_{u_\gamma}(t, y) + \omega u_\gamma(t, y), \text{ for a.a. } t \in (0, T), 0 < y < \gamma,$$

where  $f_{u_\gamma}(t, y) := f_u(t, y/\gamma)$ , and the same is true for  $v_\gamma(t, y) = v(t, y/\gamma)$ . Thus,  $u_\gamma, v_\gamma : [0, T] \rightarrow H_0^1(0, \gamma)$  are strong solutions of the problem

$$\begin{cases} \frac{\partial u}{\partial t} - \gamma^2 \frac{\partial^2 u}{\partial x^2} \in H_0(u) + \omega u, \text{ on } (0, \infty) \times (0, \gamma), \\ u(t, 0) = u(t, \gamma) = 0, \\ u(x, 0) = u_0(x). \end{cases} \quad (6.27)$$

Let  $I_\gamma = [0, \gamma]$ . In what follows, we will use the notation

$$\|v\|_{H^1(I_\gamma)} = \sqrt{\|v\|_{L^2(I_\gamma)}^2 + \left\| \frac{dv}{dx} \right\|_{L^2(I_\gamma)}^2}.$$

If  $C_\gamma$  is the constant in (6.26) for the solution  $u_\gamma$ , we need to analyze how it depends on  $\gamma$ . For the constant of nondegeneracy  $C$  of  $u$  we have

$$\mu(\{x \in (0, 1) : |u(x)| \leq \alpha\}) \leq C\alpha,$$

so

$$\begin{aligned} \mu(\{y \in (0, \gamma) : |u_\gamma(y)| \leq \alpha\}) &= \int_{|u_\gamma(y)| \leq \alpha} 1 \, dy = \int_{|u(y/\gamma)| \leq \alpha} 1 \, dy \\ &= \int_{|u(x)| \leq \alpha} \gamma \, dx = \gamma \mu(\{x \in (0, 1) : |u(x)| \leq \alpha\}) \leq \gamma \alpha C = C_\gamma \alpha, \end{aligned} \quad (6.28)$$

where  $C_\gamma = \gamma C$ .

We will prove the existence of  $\bar{L}_\infty$  (independent of  $\gamma \geq 1$ ) such that

$$\|w\|_{L^\infty(I_\gamma)} \leq \bar{L}_\infty \|w\|_{H^1(I_\gamma)}, \text{ for any } w \in H^1(I_\gamma). \quad (6.29)$$

By (BREZIS, 2011, Theorem 8.8), there is a positive constant  $\bar{C}$  such that

$$\|v\|_{H^1(\mathbb{R})} \geq \bar{C} \|v\|_{L^\infty(\mathbb{R})} \text{ for all } v \in H^1(\mathbb{R}).$$

By (BREZIS, 2011, Theorem 8.6), there exists a prolongation operator  $P_\gamma : H^1(I_\gamma) \rightarrow H^1(\mathbb{R})$  which satisfies

$$\|P_\gamma w\|_{H^1(\mathbb{R})} \leq 4 \left(1 + \frac{1}{\gamma}\right) \|w\|_{H^1(I_\gamma)} \text{ for all } w \in H^1(I_\gamma).$$

Also, by the construction it follows that  $\|P_\gamma w\|_{L^\infty(\mathbb{R})} = \|w\|_{L^\infty(I_\gamma)}$ . Hence, for  $\gamma \geq 1$ , we have

$$\|u\|_{H^1(I_\gamma)} \geq \frac{\gamma}{4(1+\gamma)} \|P_\gamma w\|_{H^1(\mathbb{R})} \geq \frac{1}{8} \|P_\gamma w\|_{H^1(\mathbb{R})} \geq \frac{\bar{C}}{8} \|P_\gamma w\|_{L^\infty(\mathbb{R})} = \frac{\bar{C}}{8} \|w\|_{L^\infty(I_\gamma)},$$

so (6.29) is true with  $\bar{L}_\infty = \frac{8}{\bar{C}}$ .

Multiplying by  $(u_\gamma(t) - v_\gamma(t))^+$  the equality

$$\frac{d}{dt} (u_\gamma - v_\gamma) - \gamma^2 \frac{\partial^2 (u_\gamma - v_\gamma)}{\partial x^2} = f_{u_\gamma}(t) - f_{v_\gamma}(t) + \omega (u_\gamma - v_\gamma),$$

where  $f_{u_\gamma}, f_{v_\gamma} \in L^\infty((0, T) \times (0, 1))$  are such that  $f_{u_\gamma}(t, x) \in H_0(u_\gamma(t, x))$ ,  $f_{v_\gamma}(t, x) \in H_0(v_\gamma(t, x))$  for a.a.  $(t, x)$ , we obtain

$$\begin{aligned} & \frac{1}{2} \frac{d}{dt} \|(u_\gamma - v_\gamma)^+\|_{L^2(I_\gamma)}^2 + \gamma^2 \|(u_\gamma - v_\gamma)^+\|_{H_0^1(I_\gamma)}^2 \\ & \leq \int_0^\gamma (f_{u_\gamma}(t, x) - f_{v_\gamma}(t, x))(u_\gamma(t, x) - v_\gamma(t, x))^+ dx + \frac{\omega \gamma^2}{\pi^2} \|(u_\gamma - v_\gamma)^+\|_{H_0^1(I_\gamma)}^2. \end{aligned}$$

Hence, by Remark 6.3.13 and (6.28) we have

$$\begin{aligned} & \frac{1}{2} \frac{d}{dt} \|(u_\gamma - v_\gamma)^+\|_{L^2(I_\gamma)}^2 + \gamma^2 \left(1 - \frac{\omega}{\pi^2}\right) \|(u_\gamma - v_\gamma)^+\|_{H^1(I_\gamma)}^2 \\ & \leq 2 \max \left\{ \gamma C, \frac{1}{\alpha_0} \right\} \|(u_\gamma - v_\gamma)^+\|_{L^\infty(I_\gamma)}^2 + \gamma^2 \left(1 - \frac{\omega}{\pi^2}\right) \|(u_\gamma - v_\gamma)^+\|_{L^2(I_\gamma)}^2, \end{aligned}$$

so

$$\begin{aligned} & \frac{1}{2} \frac{d}{dt} \|(u_\gamma - v_\gamma)^+\|_{L^2(I_\gamma)}^2 \\ & \leq \gamma^2 \left(1 - \frac{\omega}{\pi^2}\right) \|(u_\gamma - v_\gamma)^+\|_{L^2(I_\gamma)}^2 + \left(2C\gamma - \frac{\gamma^2(\pi^2 - \omega)}{\bar{L}_\infty \pi^2}\right) \|(u_\gamma - v_\gamma)^+\|_{L^\infty(I_\gamma)}^2 \\ & \leq \gamma^2 \left(1 - \frac{\omega}{\pi^2}\right) \|(u_\gamma - v_\gamma)^+\|_{L^2(I_\gamma)}^2, \end{aligned}$$

for  $\gamma$  great enough. Thus,

$$\|(u_\gamma - v_\gamma)^+(t)\|_{L^2(I_\gamma)}^2 \leq e^{\delta t} \|(u_\gamma - v_\gamma)^+(0)\|_{L^2(I_\gamma)}^2 = 0,$$

for  $\delta = 2\gamma^2 \left(1 - \frac{\omega}{\pi^2}\right)$ . Hence,  $u_\gamma(t) \leq v_\gamma(t)$  and then  $u(t) \leq v(t)$  for all  $t \in [0, T]$ .  $\square$

**Corollary 6.3.15.** If  $u, v : [0, T] \rightarrow H_0^1(\Omega)$  are two strong solutions such that  $u(0) = v(0) = u_0$  and either  $u$  or  $v$  is degenerate on  $[0, T]$ , then  $u(t) = v(t)$  for all  $t \in [0, T]$ .

**Lemma 6.3.16.** The fixed points  $v_k^\pm$ ,  $k \in \mathbb{N}$ , are nondegenerate.

*Proof.* Let us consider first the point  $v_1^+$  and denote  $(v_1^+)'(0) = \gamma_0 > 0$ . We choose  $0 < x_0 < \frac{1}{2}$  such that  $(v_1^+)'(x) \geq \frac{\gamma_0}{2}$  for any  $x \in [0, x_0]$ . Then for  $0 < \alpha_0 \leq v_1^+(x_0)$ , we have

$$v_1^+(x) \geq \alpha_0, \quad \forall x \in [x_0, 1 - x_0],$$

$$v_1^+(1-x) = v_1^+(x) = (v_1^+)'(\bar{x})x \geq \frac{\gamma_0}{2}x, \quad \forall x \in [0, x_0].$$

Hence, for  $0 < \alpha < \alpha_0$  and  $x \in [0, x_0]$  such that  $v_1^+(x) \leq \alpha$  we obtain that

$$\frac{\gamma_0}{2}x \leq \alpha,$$

so by symmetry,

$$\mu(\{x \in (0, 1) : v_1^+(x) \leq \alpha\}) \leq \frac{4}{\gamma_0}\alpha.$$

Therefore,  $v_1^+$  is nondegenerate and then so is  $v_1^-$ .

By symmetry, we easily deduce that, for all  $k \in \mathbb{N}$ ,

$$\mu(\{x \in (0, 1) : |v_k^\pm(x)| \leq \alpha\}) \leq \frac{4k}{\gamma_0}\alpha,$$

where  $(v_k^+)'(0) = \gamma_0$  and  $x_0, \alpha_0$  are such that  $0 < x_0 < \frac{1}{2k}$ ,  $(v_k^+)'(x) \geq \frac{\gamma_0}{2}$ , for any  $x \in [0, x_0]$ , and  $0 < \alpha_0 \leq v_k^+(x_0)$ .

Thus,  $v_k^\pm$  are nondegenerate, for all  $k \in \mathbb{N}$ . □

From the previous corollary and the fact that the fixed points  $v_k^\pm$  are nondegenerate,  $k \in \mathbb{N}$ , we obtain the following result.

**Corollary 6.3.17.** For any  $k \geq 1$ , the solution  $u(\cdot)$  with initial condition  $u(0) = v_k^\pm$  is unique on  $[0, +\infty)$ . That means, the solution starting at the nonzero equilibria are unique.

Finally, we will define a suitable neighborhood of the point  $v_k^\pm$  where all the solutions are uniquely defined, for all  $k \in \mathbb{N}$ . We consider the space  $X = V^{2r} = D(A^r)$  with  $\frac{3}{4} < r < 1$ . We know that  $X$  is continuously embedded into the space  $C^1([0, 1])$ . We denote by  $O_\delta(v_0) = \{v \in X : \|v - v_0\|_X < \delta\}$  a  $\delta$ -neighborhood of the point  $v_0 \in X$ .

**Lemma 6.3.18.** For any  $v_k^\pm, k \in \mathbb{N}$ , there exist  $\delta, C, \alpha_0 > 0$  such that

$$\mu(\{x \in (0, 1) : |v(x)| \leq \alpha\}) \leq C\alpha \quad \forall v \in O_\delta(v_k^\pm).$$

*Proof.* We will analyze the function  $v_2^-$ . The proof is rather similar for the other points.

Denote  $\gamma_0 = (v_2^-)'(0) > 0$ . Since  $X \subset C^1([0, 1])$ , we can choose  $\delta > 0, 0 < x_0 < \frac{1}{2}$  such that any  $v \in O_\delta(v_2^-)$  satisfies:

- $v$  has only one zero  $x_v$  in  $(0, 1)$  and  $x_v \in (\frac{1}{2} - x_0, \frac{1}{2} + x_0)$ ;
- $v'(x) \geq \frac{\gamma_0}{2}$  for all  $x \in [\frac{1}{2} - x_0, \frac{1}{2} + x_0]$ ;
- $v'(x) \leq -\frac{\gamma_0}{2}$  for all  $x \in [0, x_0] \cup [1 - x_0, 1]$ ;
- $|v(x)| \geq \alpha_0$  for all  $x \in [x_0, \frac{1}{2} - x_0] \cup [\frac{1}{2} + x_0, 1 - x_0]$ ,

where  $\alpha_0 < v_2^-(\frac{1}{2} + x_0)$ . Hence,

$$\begin{aligned} v(x) &= v'(x_1^v)(x - x_v) \geq \frac{\gamma_0}{2}(x - x_v), \text{ for } x \in [x_v, \frac{1}{2} + x_0], \\ v(x) &= v'(x_2^v)(x - x_v) \leq \frac{\gamma_0}{2}(x - x_v), \text{ for } x \in [\frac{1}{2} - x_0, x_v], \\ v(x) &= v'(x_3^v)x \leq -\frac{\gamma_0}{2}x, \text{ for } x \in [0, x_0], \\ v(x) &= v'(x_4^v)(x - 1) \geq \frac{\gamma_0}{2}(1 - x), \text{ for } x \in [1 - x_0, 1]. \end{aligned}$$

Therefore,

$$\mu(\{x \in (0, 1) : |v(x)| \leq \alpha\}) \leq \frac{8}{\gamma_0} \alpha.$$

□

**Remark 6.3.19.** This result means that the functions are uniformly nondegenerate in some neighborhood  $O_\delta(v_k^\pm)$ ,  $k \in \mathbb{N}$ .

Let  $u_0 \in O_\delta(v_k^\pm)$  and  $u(\cdot) \in \mathcal{D}(u_0)$ ,  $k \in \mathbb{N}$ . Let  $T_{\max}$  be the maximal time such that  $u(t) \in O_\delta(v_k^\pm)$  for all  $t \in [0, T_{\max})$ . Then from Lemmas 6.3.15, 6.3.18 we deduce that  $u(\cdot)$  is the unique solution on  $[0, T_{\max})$  (and if  $T_{\max} < \infty$ , it is the unique solution on  $[0, T_{\max}]$ ).

**Remark 6.3.20.** For the semigroup defined on  $O_\delta(v_k^\pm)$ ,  $k \in \mathbb{N}$ , we could apply Theorem 5.1 from (RYBAKOWSKI, 1987) in order to obtain the existence of an isolating block.

## 6.4 Conclusion and next steps

We have presented an abstract result proving the existence of isolating blocks for multivalued semiflows. Hence, given an isolated weakly invariant set defined for a multivalued semiflow satisfying (K1)-(K5), we can find a special neighborhood for which the boundaries are completely oriented in some sense. We believe that our construction of isolating blocks for multivalued semiflows is the first of its kind, so as the application to differential inclusions.

In the single-valued case, such a neighborhood of an isolated weakly invariant set is essential and gives the inspiration for the definition of Conley's index. It can be shown that the isolating block together with its boundary has the cofibration property. In fact, the quotient space defined by the isolating block over its boundary is the Conley index. This is also true in the context of metric spaces which are not necessarily locally compact, see (RYBAKOWSKI, 1987, Theorem 5.1).

Having the concept of isolating blocks a very close relation with Conley's index, we may wonder if we can define a homology index for multivalued semiflows. This is a subject for further studies. It is important to say that there are already very nice and interesting works that propose some definitions of Conley's index in the multivalued setting, see e.g. (MROZEK, 1990)

and (DZEDZEJ; GABOR, 2011). Once we will have a candidate for the definition of Conley's index, we will try to understand if we are able to present something new with that definition and which is the relation of this new concept with the ones proposed in the previous works. We hope to achieve an answer to these questions in the future.





## BIBLIOGRAPHY

---

BREZIS, Haim. Citation on page [109](#).

ANGENENT, S. B. The Morse-Smale property for a semilinear parabolic equation. **J. Differential Equations**, v. 62, n. 3, p. 427–442, 1986. ISSN 0022-0396. Available: [https://doi.org/10.1016/0022-0396\(86\)90093-8](https://doi.org/10.1016/0022-0396(86)90093-8). Citation on page [51](#).

ARRIETA, J. M.; CARVALHO, A. N.; MOREIRA, E. M.; VALERO, J. Bifurcation and hyperbolicity for a nonlocal quasilinear parabolic problem. Submitted for publication. 2022. Citations on pages [22](#), [77](#), [79](#), and [108](#).

ARRIETA, J. M.; RODRÍGUEZ-BERNAL, A.; VALERO, J. Dynamics of a reaction-diffusion equation with a discontinuous nonlinearity. **Internat. J. Bifur. Chaos Appl. Sci. Engrg.**, v. 16, n. 10, p. 2965–2984, 2006. ISSN 0218-1274. Available: <https://doi.org/10.1142/S0218127406016586>. Citations on pages [21](#), [135](#), [136](#), and [137](#).

BALL, J. M. Continuity properties and global attractors of generalized semiflows and the Navier-Stokes equations [MR1462276 (98j:58071a),b]. In: **Mechanics: from theory to computation**. [S.l.]: Springer, New York, 2000. p. 447–474. Citation on page [21](#).

BARBU, V. **Nonlinear semigroups and differential equations in Banach spaces**. [S.l.]: Editura Academiei Republicii Socialiste România, Bucharest; Noordhoff International Publishing, Leiden, 1976. 352 p. Translated from the Romanian. Citations on pages [116](#) and [134](#).

BŁAŚCZYK, Z.; GOŁĘBIEWSKA, A.; RYBICKI, S. Conley index in Hilbert spaces versus the generalized topological degree. **Adv. Differential Equations**, v. 22, n. 11-12, p. 963–982, 2017. ISSN 1079-9389. Available: <https://projecteuclid.org/euclid.ade/1504231227>. Citation on page [109](#).

BORTOLAN, M. C.; CARVALHO, A.; LANGA, J. A.; RAUGEL, G. Nonautonomous perturbations of morse–smale semigroups: Stability of the phase diagram. **J Dyn Diff Equat**, 2021. Citation on page [51](#).

BORTOLAN, M. C.; CARVALHO, A. N.; LANGA, J. A. **Attractors under autonomous and non-autonomous perturbations**. [S.l.]: American Mathematical Society, Providence, RI, 2020. 246 p. (Mathematical Surveys and Monographs, v. 246). ISBN 978-1-4704-5308-4. Citations on pages [51](#), [61](#), and [88](#).

BREZIS, H. **Functional analysis, Sobolev spaces and partial differential equations**. [S.l.]: Springer, New York, 2011. xiv+599 p. (Universitext). ISBN 978-0-387-70913-0. Citation on page [142](#).

BROCHE, R. d. C. D. S.; CARVALHO, A. N.; VALERO, J. A non-autonomous scalar one-dimensional dissipative parabolic problem: the description of the dynamics. **Nonlinearity**, v. 32, n. 12, p. 4912–4941, 2019. ISSN 0951-7715. Available: <https://doi.org/10.1088/1361-6544/ab3f55>. Citation on page [60](#).

CABALLERO, R.; CARVALHO, A. N.; MARÍN-RUBIO, P.; VALERO, J. About the structure of attractors for a nonlocal chafee-infante problem. **Mathematics**, v. 9, n. 4, 2021. ISSN 2227-7390. Available: <<https://www.mdpi.com/2227-7390/9/4/353>>. Citations on pages 56, 79, 81, 98, 102, 103, and 108.

CARVALHO, A. N. Análise funcional ii. Notes, ICMC-USP. 2017. Citation on page 38.

CARVALHO, A. N.; LANGA, J. A. An extension of the concept of gradient semigroups which is stable under perturbation. **J. Differential Equations**, v. 246, n. 7, p. 2646–2668, 2009. ISSN 0022-0396. Available: <<https://doi.org/10.1016/j.jde.2009.01.007>>. Citation on page 26.

CARVALHO, A. N.; LANGA, J. A.; ROBINSON, J. C. Structure and bifurcation of pull-back attractors in a non-autonomous Chafee-Infante equation. **Proc. Amer. Math. Soc.**, v. 140, n. 7, p. 2357–2373, 2012. ISSN 0002-9939. Available: <<https://doi.org/10.1090/S0002-9939-2011-11071-2>>. Citations on pages 22, 23, 60, 61, 62, and 65.

\_\_\_\_\_. **Attractors for infinite-dimensional non-autonomous dynamical systems**. Springer, New York, 2013. xxxvi+409 p. (Applied Mathematical Sciences, v. 182). ISBN 978-1-4614-4580-7; 978-1-4614-4581-4. Available: <<https://doi.org/10.1007/978-1-4614-4581-4>>. Citations on pages 19, 26, 33, 39, 42, 45, 47, 49, 60, and 99.

CARVALHO, A. N.; LAPPICY, P.; OLIVEIRA-SOUSA. A unified theory for inertial manifolds, saddle point property and exponential dichotomy. Submitted for publication. 2021. Citation on page 63.

CARVALHO, A. N.; MOREIRA, E. M. Stability and hyperbolicity of equilibria for a scalar nonlocal one-dimensional quasilinear parabolic problem. **J. Differential Equations**, v. 300, p. 312–336, 2021. ISSN 0022-0396. Available: <<https://doi.org/10.1016/j.jde.2021.07.044>>. Citations on pages 22, 77, 81, 82, 89, 102, and 108.

CATCHPOLE, E. A. A Cauchy problem for an ordinary integro-differential equation. **Proc. Roy. Soc. Edinburgh Sect. A**, v. 72, n. 1, p. 39–55, 1974. ISSN 0308-2105. Citation on page 85.

CHAFEE, N.; INFANTE, E. F. Bifurcation and stability for a nonlinear parabolic partial differential equation. **Bull. Amer. Math. Soc.**, v. 80, p. 49–52, 1974. ISSN 0002-9904. Available: <<https://doi.org/10.1090/S0002-9904-1974-13349-5>>. Citations on pages 20, 51, 53, and 62.

\_\_\_\_\_. A bifurcation problem for a nonlinear partial differential equation of parabolic type. **Applicable Anal.**, v. 4, p. 17–37, 1974/75. ISSN 0003-6811. Available: <<https://doi.org/10.1080/00036817408839081>>. Citations on pages 20, 51, 54, 56, and 62.

CHOLEWA, J. W.; DLOTKO, T. **Global attractors in abstract parabolic problems**. Cambridge University Press, Cambridge, 2000. xii+235 p. (London Mathematical Society Lecture Note Series, v. 278). ISBN 0-521-79424-2. Available: <<https://doi.org/10.1017/CBO9780511526404>>. Citations on pages 23 and 36.

CONLEY, C. **Isolated invariant sets and the Morse index**. [S.l.]: American Mathematical Society, Providence, R.I., 1978. iii+89 p. (CBMS Regional Conference Series in Mathematics, v. 38). ISBN 0-8218-1688-8. Citations on pages 20, 24, 28, and 109.

COPPEL, W. A. **Dichotomies in stability theory**. [S.l.]: Springer-Verlag, Berlin-New York, 1978. ii+98 p. (Lecture Notes in Mathematics, Vol. 629). ISBN 3-540-08536-X. Citation on page 45.

COSTA, E. R. Aragão; CARABALLO, T.; CARVALHO, A. N.; LANGA, J. A. Stability of gradient semigroups under perturbations. **Nonlinearity**, v. 24, n. 7, p. 2099–2117, 2011. ISSN 0951-7715. Available: <<https://doi.org/10.1088/0951-7715/24/7/010>>. Citations on pages 26, 27, and 28.

COSTA, H. B. da; VALERO, J. Morse decompositions with infinite components for multivalued semiflows. **Set-Valued Var. Anal.**, v. 25, n. 1, p. 25–41, 2017. ISSN 1877-0533. Available: <<https://doi.org/10.1007/s11228-016-0363-x>>. Citations on pages 113, 120, 135, and 136.

DASHKOVSKIY, S.; KAPUSTYAN, O.; PERESTYUK, Y. Stability of uniform attractors of impulsive multi-valued semiflows. **Nonlinear Anal. Hybrid Syst.**, v. 40, p. Paper No. 101025, 16, 2021. ISSN 1751-570X. Available: <<https://doi.org/10.1016/j.nahs.2021.101025>>. Citation on page 21.

DAVIDSON, F. A.; DODDS, N. Spectral properties of non-local differential operators. **Appl. Anal.**, v. 85, n. 6-7, p. 717–734, 2006. ISSN 0003-6811. Available: <<https://doi.org/10.1080/00036810600555171>>. Citation on page 85.

DODDS, N. Further spectral properties of uniformly elliptic operators that include a non-local term. **Appl. Math. Comput.**, v. 197, n. 1, p. 317–327, 2008. ISSN 0096-3003. Available: <<https://doi.org/10.1016/j.amc.2007.07.049>>. Citation on page 85.

DZEDZEJ, Z.; GABOR, G. On homotopy Conley index for multivalued flows in Hilbert spaces. **Topol. Methods Nonlinear Anal.**, v. 38, n. 1, p. 187–205, 2011. ISSN 1230-3429. Citations on pages 21, 109, and 146.

FEIREISL, E.; NORBURY, J. Some existence, uniqueness and nonuniqueness theorems for solutions of parabolic equations with discontinuous nonlinearities. **Proc. Roy. Soc. Edinburgh Sect. A**, v. 119, n. 1-2, p. 1–17, 1991. ISSN 0308-2105. Available: <<https://doi.org/10.1017/S0308210500028262>>. Citation on page 134.

FIEDLER, B.; ROCHA, C. Heteroclinic orbits of semilinear parabolic equations. **J. Differential Equations**, v. 125, n. 1, p. 239–281, 1996. ISSN 0022-0396. Available: <<https://doi.org/10.1006/jdeq.1996.0031>>. Citations on pages 51 and 58.

FRANZOSA, R. Index filtrations and the homology index braid for partially ordered Morse decompositions. **Trans. Amer. Math. Soc.**, v. 298, n. 1, p. 193–213, 1986. ISSN 0002-9947. Available: <<https://doi.org/10.2307/2000615>>. Citations on pages 20 and 30.

FRANZOSA, R.; MISCHAIKOW, K. Algebraic transition matrices in the Conley index theory. **Trans. Amer. Math. Soc.**, v. 350, n. 3, p. 889–912, 1998. ISSN 0002-9947. Available: <<https://doi.org/10.1090/S0002-9947-98-01666-3>>. Citation on page 30.

FRANZOSA, R. D. The continuation theory for Morse decompositions and connection matrices. **Trans. Amer. Math. Soc.**, v. 310, n. 2, p. 781–803, 1988. ISSN 0002-9947. Available: <<https://doi.org/10.2307/2000991>>. Citations on pages 20, 30, 31, 32, 105, and 107.

\_\_\_\_\_. The connection matrix theory for Morse decompositions. **Trans. Amer. Math. Soc.**, v. 311, n. 2, p. 561–592, 1989. ISSN 0002-9947. Available: <<https://doi.org/10.2307/2001142>>. Citations on pages 20, 24, 30, and 31.

FREITAS, P. A nonlocal Sturm-Liouville eigenvalue problem. **Proc. Roy. Soc. Edinburgh Sect. A**, v. 124, n. 1, p. 169–188, 1994. ISSN 0308-2105. Available: <<https://doi.org/10.1017/S0308210500029279>>. Citation on page 85.

HENRY, D. **Geometric theory of semilinear parabolic equations**. [S.l.]: Springer-Verlag, Berlin-New York, 1981. iv+348 p. (Lecture Notes in Mathematics, v. 840). ISBN 3-540-10557-3. Citations on pages 13, 19, 20, 33, 36, 38, 39, 40, 42, 44, 45, 54, and 56.

HENRY, D. B. Some infinite-dimensional Morse-Smale systems defined by parabolic partial differential equations. **J. Differential Equations**, v. 59, n. 2, p. 165–205, 1985. ISSN 0022-0396. Available: <[https://doi.org/10.1016/0022-0396\(85\)90153-6](https://doi.org/10.1016/0022-0396(85)90153-6)>. Citations on pages 51, 57, 58, and 107.

IZYDOREK, M.; ROT, T. O.; STAROSTKA, M.; STYBORSKI, M.; VANDERVORST, R. C. A. M. Homotopy invariance of the Conley index and local Morse homology in Hilbert spaces. **J. Differential Equations**, v. 263, n. 11, p. 7162–7186, 2017. ISSN 0022-0396. Available: <<https://doi.org/10.1016/j.jde.2017.08.007>>. Citation on page 109.

JÄNIG, A. Nonautonomous Conley index theory. The homology index and attractor-repeller decompositions. **Topol. Methods Nonlinear Anal.**, v. 53, n. 1, p. 57–77, 2019. ISSN 1230-3429. Available: <<https://doi.org/10.12775/tmna.2018.039>>. Citation on page 109.

KAPUSTYAN, O. V.; KASYANOV, P. O.; VALERO, J. Structure and regularity of the global attractor of a reaction-diffusion equation with non-smooth nonlinear term. **Discrete Contin. Dyn. Syst.**, v. 34, n. 10, p. 4155–4182, 2014. ISSN 1078-0947. Available: <<https://doi.org/10.3934/dcds.2014.34.4155>>. Citations on pages 112 and 138.

LADYZHENSKAYA, O. **Attractors for semigroups and evolution equations**. Cambridge University Press, Cambridge, 1991. xii+73 p. (Lezioni Lincee. [Lincei Lectures]). ISBN 0-521-39030-3. Available: <<https://doi.org/10.1017/CBO9780511569418>>. Citation on page 23.

LI, Y.; CARVALHO, A. N.; LUNA, T. L. M.; MOREIRA, E. M. A non-autonomous bifurcation problem for a non-local scalar one-dimensional parabolic equation. **Commun. Pure Appl. Anal.**, v. 19, n. 11, p. 5181–5196, 2020. ISSN 1534-0392. Available: <<https://doi.org/10.3934/cpaa.2020232>>. Citations on pages 22, 77, 81, and 108.

LUNARDI, A. **Analytic semigroups and optimal regularity in parabolic problems**. [S.l.]: Birkhäuser/Springer Basel AG, Basel, 1995. xviii+424 p. (Modern Birkhäuser Classics). [2013 reprint of the 1995 original] [MR1329547]. ISBN 978-3-0348-0556-8; 978-3-0348-0557-5. Citations on pages 76 and 87.

MATANO, H. Nonincrease of the lap-number of a solution for a one-dimensional semilinear parabolic equation. **J. Fac. Sci. Univ. Tokyo Sect. IA Math.**, v. 29, n. 2, p. 401–441, 1982. ISSN 0040-8980. Citation on page 56.

MELNIK, V. S.; VALERO, J. On attractors of multivalued semi-flows and differential inclusions. **Set-Valued Anal.**, v. 6, n. 1, p. 83–111, 1998. ISSN 0927-6947. Available: <<https://doi.org/10.1023/A:1008608431399>>. Citations on pages 21, 115, 137, and 138.

MISCHAIKOW, K. Global asymptotic dynamics of gradient-like bistable equations. **SIAM J. Math. Anal.**, v. 26, n. 5, p. 1199–1224, 1995. ISSN 0036-1410. Available: <<https://doi.org/10.1137/S0036141093250827>>. Citations on pages 59, 60, 108, and 109.

MOREIRA, E. M.; VALERO, J. The existence of isolating blocks for multivalued semiflows. Submitted for publication. 2022. Citations on pages 22, 110, and 118.



\_\_\_\_\_. Structure of the attractor for a non-local Chafee-Infante problem. **J. Math. Anal. Appl.**, v. 507, n. 2, p. Paper No. 125801, 25, 2022. ISSN 0022-247X. Available: <<https://doi.org/10.1016/j.jmaa.2021.125801>>. Citations on pages 22, 77, and 108.

MROZEK, M. A cohomological index of Conley type for multi-valued admissible flows. **J. Differential Equations**, v. 84, n. 1, p. 15–51, 1990. ISSN 0022-0396. Available: <[https://doi.org/10.1016/0022-0396\(90\)90125-9](https://doi.org/10.1016/0022-0396(90)90125-9)>. Citations on pages 21, 109, and 145.

NORTH, G. R.; CAHALAN, R. F. Predictability in a solvable stochastic climate model. **J. Atmos. Sci.**, v. 38, n. 3, p. 504–513, 1981. Available: <[https://journals.ametsoc.org/view/journals/atsc/38/3/1520-0469\\_1981\\_038\\_0504\\_piassc\\_2\\_0\\_co\\_2.xml](https://journals.ametsoc.org/view/journals/atsc/38/3/1520-0469_1981_038_0504_piassc_2_0_co_2.xml)>. Citation on page 134.

PAZY, A. **Semigroups of linear operators and applications to partial differential equations**. Springer-Verlag, New York, 1983. viii+279 p. (Applied Mathematical Sciences, v. 44). ISBN 0-387-90845-5. Available: <<https://doi.org/10.1007/978-1-4612-5561-1>>. Citation on page 23.

RYBAKOWSKI, K. P. **The homotopy index and partial differential equations**. Springer-Verlag, Berlin, 1987. xii+208 p. (Universitext). ISBN 3-540-18067-2. Available: <<https://doi.org/10.1007/978-3-642-72833-4>>. Citations on pages 20, 24, 28, 29, 30, 109, 110, 117, 118, 119, 123, 124, and 145.

SAGAN, H. **Boundary and eigenvalue problems in mathematical physics**. [S.l.]: John Wiley & Sons, Inc., New York-London, 1961. xviii+381 p. Citation on page 19.

SMOLLER, J. **Shock waves and reaction-diffusion equations**. Second. Springer-Verlag, New York, 1994. xxiv+632 p. (Grundlehren der Mathematischen Wissenschaften [Fundamental Principles of Mathematical Sciences], v. 258). ISBN 0-387-94259-9. Available: <<https://doi.org/10.1007/978-1-4612-0873-0>>. Citation on page 54.

TERMAN, D. A free boundary problem arising from a bistable reaction-diffusion equation. **Siam J. Math. Anal.**, v. 14, n. 6, p. 1107–1129, 1983. ISSN 0036-1410. Available: <<https://doi.org/10.1137/0514086>>. Citation on page 134.

\_\_\_\_\_. A free boundary arising from a model for nerve conduction. **J. Differential Equations**, v. 58, n. 3, p. 345–363, 1985. ISSN 0022-0396. Available: <[https://doi.org/10.1016/0022-0396\(85\)90004-X](https://doi.org/10.1016/0022-0396(85)90004-X)>. Citation on page 134.

TOLSTONOGOV, A. A. Solutions of evolution inclusions. I. **Sibirsk. Mat. Zh.**, v. 33, n. 3, p. 161–174, 221, 1992. ISSN 0037-4474. Available: <<https://doi.org/10.1007/BF00970899>>. Citations on pages 116 and 138.

TRIEBEL, H. **Interpolation theory, function spaces, differential operators**. Second. [S.l.]: Johann Ambrosius Barth, Heidelberg, 1995. 532 p. ISBN 3-335-00420-5. Citation on page 39.

VALERO, J. Attractors of parabolic equations without uniqueness. **J. Dynam. Differential Equations**, v. 13, n. 4, p. 711–744, 2001. ISSN 1040-7294. Available: <<https://doi.org/10.1023/A:1016642525800>>. Citation on page 135.

\_\_\_\_\_. On the Kneser property for some parabolic problems. **Topology Appl.**, v. 153, n. 5-6, p. 975–989, 2005. ISSN 0166-8641. Available: <<https://doi.org/10.1016/j.topol.2005.01.025>>. Citation on page 135.

\_\_\_\_\_. Characterization of the attractor for nonautonomous reaction-diffusion equations with discontinuous nonlinearity. **J. Differential Equations**, v. 275, p. 270–308, 2021. ISSN 0022-0396. Available: <<https://doi.org/10.1016/j.jde.2020.11.036>>. Citation on page 137.

ZGUROVSKY, M. Z.; KASYANOV, P. O.; KAPUSTYAN, O. V.; VALERO, J.; ZADOIANCHUK, N. V. **Evolution inclusions and variation inequalities for earth data processing. III**. Springer, Heidelberg, 2012. xlii+330 p. (Advances in Mechanics and Mathematics, v. 27). Long-time behavior of evolution inclusions solutions in earth data analysis. ISBN 978-3-642-28511-0; 978-3-642-28512-7. Available: <<https://doi.org/10.1007/978-3-642-28512-7>>. Citation on page 21.



